



BMW Motorrad



The Ultimate  
Riding Machine

# Rider's Manual F 700 GS

## Vehicle data/dealership details

### Vehicle data

---

Model

---

Vehicle Identification Number

---

Colour code

---

Date of first registration

---

Registration number

### Dealership details

---

Person to contact in Service department

---

Ms/Mr

---

Phone number

---

Dealership address/phone number (company stamp)

## **Welcome to BMW**

We congratulate you on your choice of a vehicle from BMW Motorrad and welcome you to the community of BMW riders. Familiarise yourself with your new vehicle so that you can ride it safely and confidently in all traffic situations.

### **About this Rider's Manual**

Please read this Rider's Manual carefully before starting to use your new BMW. It contains important information on how to operate the controls and how to make the best possible use of all your BMW's technical features. In addition, it contains information on maintenance and care to help you maintain your vehicle's reliability and safety, as well as its value.

### **Suggestions and criticism**

If you have questions concerning your motorcycle, your authorised BMW Motorrad dealer will gladly provide advice and assistance.

We hope you will enjoy riding your BMW and that all your journeys will be pleasant and safe

BMW Motorrad.

01 41 8 559 331



# Table of Contents

<b>1 General instructions ....</b>	<b>5</b>	Fuel level .....	25	Damping .....	53
Overview .....	6	Fuel reserve .....	25	Electronic Suspension Ad-justment ESA .....	55
Abbreviations and symbols .....	6	Service-due indicator .....	25	Tyres .....	56
Equipment .....	7	Ambient temperature .....	26	Headlight .....	57
Technical data .....	7	Tyre pressures .....	26	Seat .....	58
Actuality .....	7	Warnings .....	27	Helmet holder .....	58
<b>2 General views .....</b>	<b>9</b>	<b>4 Operation .....</b>	<b>39</b>	Rider's Manual .....	59
General view, left side .....	11	Ignition switch .....	40	<b>5 Anti-theft alarm</b>	
General view, right side .....	13	Electronic immobiliser .....	41	<b>DWA .....</b>	<b>61</b>
Underneath the seat .....	14	Clock .....	41	Overview .....	62
Underneath the trim panel .....	15	Reading .....	42	Activation .....	62
Multifunction switch, left ....	16	Stopwatch .....	43	Alarm function .....	64
Multifunction switch, right .....	17	Lights .....	45	Deactivation .....	65
Instrument panel .....	18	Turn indicators .....	46	Programming .....	66
<b>3 Status indicators .....</b>	<b>21</b>	Hazard warning flashers .....	46	Registration of the remote control .....	68
Multifunction display .....	22	Emergency off switch (kill switch) .....	47	Synchronising .....	69
Meaning of symbols .....	23	Grip heating .....	47	Battery .....	70
Warning and telltale lights .....	24	BMW Motorrad ABS .....	48	<b>6 Riding .....</b>	<b>71</b>
		BMW Motorrad ASC .....	49	Safety instructions .....	72
		Clutch .....	50	Comply with checklist .....	75
		Brakes .....	51	Starting .....	76
		Mirrors .....	52		
		Spring preload .....	52		

Running in .....	78	<b>9 Maintenance .....</b>	<b>103</b>	Restoring motorcycle to use .....	140
Speed .....	79	General instructions .....	104	<b>11 Technical data .....</b>	<b>141</b>
Off-roading .....	80	Toolkit.....	104	Troubleshooting chart.....	142
Brakes .....	81	Engine oil .....	105	Threaded fasteners .....	143
Parking your motorcycle ....	82	Brake system .....	107	Engine .....	145
Refuelling .....	82	Coolant.....	111	Fuel .....	146
Securing motorcycle for transportation .....	84	Clutch.....	111	Engine oil .....	147
<b>7 Engineering details.....</b>	<b>87</b>	Rims and tyres .....	112	Clutch .....	148
Brake system with		Chain.....	113	Transmission.....	148
BMW Motorrad ABS .....	88	Wheels .....	115	Rear-wheel drive .....	149
Electronic engine management with BMW Motorrad		Front-wheel stand.....	123	Running gear.....	149
ASC .....	90	Bulbs.....	124	Brakes .....	150
Tyre pressure monitoring		Body panels.....	129	Wheels and tyres.....	151
RDC.....	91	Air filter.....	131	Electrics .....	152
		Jump-starting .....	131	Frame .....	153
		Battery .....	133	Dimensions .....	154
<b>8 Accessories .....</b>	<b>93</b>	<b>10 Care .....</b>	<b>137</b>	Weights .....	155
General instructions .....	94	Care products.....	138	Riding specifications .....	155
Power sockets .....	94	Washing the vehicle.....	138	<b>12 Service .....</b>	<b>157</b>
Luggage .....	95	Cleaning easily damaged		BMW Motorrad Service ...	158
Cases .....	95	components.....	139	BMW Motorrad Mobility	
Topcase.....	99	Paint care .....	139	services .....	158
		Laying up the motorcycle .....	140	Maintenance work.....	158
		Protective wax coating ....	140	Maintenance schedule ....	161

Standard BMW service....	162
Confirmation of maintenance work .....	163
Confirmation of service....	168
<b>13 Appendix.....</b>	<b>171</b>
Certificate for electronic immobiliser .....	172
Certificate for tyre pressure monitoring (Reifendruck-Control, RDC) .....	174
<b>14 Index .....</b>	<b>175</b>

## General instructions

Overview .....	6
Abbreviations and symbols .....	6
Equipment .....	7
Technical data .....	7
Actuality .....	7

## Overview

Chapter 2 of this Rider's Manual will provide you with an initial overview of your motorcycle. All maintenance and servicing work on the vehicle is documented in Chapter 11. This record of the maintenance work you have had performed on your vehicle is a precondition for generous treatment of goodwill claims.

When the time comes to sell your BMW, please remember to hand over this Rider's Manual; it is an important part of the motorcycle.

## Abbreviations and symbols

 **CAUTION** Low-risk hazard. Non-avoidance can lead to slight or moderate injury.

 **WARNING** Medium-risk hazard. Non-avoidance can lead to fatal or severe injury.

 **DANGER** High-risk hazard. Non-avoidance leads to fatal or severe injury.

 **ATTENTION** Special notes and precautionary measures. Non-compliance can lead to damage to the vehicle or accessory and, consequently, to voiding of the warranty.

 **NOTICE** Specific instructions on how to operate, control, adjust or look after items of equipment on the vehicle.

◀ Indicates the end of an item of information.

• Instruction.

» Result of an activity.

➔ Reference to a page with more detailed information.

◁ Indicates the end of a passage relating to specific accessories or items of equipment.

 Tightening torque.

 Technical data.

OE Optional extras. The vehicles are assembled complete with all the BMW Motorrad optional extras originally ordered.

- OA Optional accessories.  
You can obtain BMW Motorrad optional accessories through your authorised BMW Motorrad dealer; optional accessories have to be retrofitted to the vehicle.
- EWS Electronic immobiliser.
- DWA Anti-theft alarm (Diebstahlwarnanlage).
- ABS Anti-lock brake system.
- ASC Automatic Stability Control.
- ESA Electronic Suspension Adjustment.
- RDC Tyre pressure monitoring.

## Equipment

When you ordered your BMW motorcycle, you chose various items of custom equipment. This Rider's Manual describes optional extras (OE) offered by BMW and selected optional accessories (OA). This explains why the manual may also contain descriptions of equipment which you have not ordered. Please note, too, that your motorcycle might not be exactly as illustrated in this manual on account of country-specific differences. If your BMW was supplied with equipment not described in this Rider's Manual, you will find these features described in separate manuals.

## Technical data

All dimensions, weights and power ratings stated in the Rider's Manual are quoted to the standards and comply with the tolerance requirements of the Deutsches Institut für Normung e.V. (DIN). Versions for individual countries may differ.

## Actuality

The high safety and quality standards of BMW motorcycles are maintained by constant development work on designs, equipment and accessories. Because of this, your motorcycle may differ from the information supplied in the Rider's Manual. Nor can BMW Motorrad entirely rule out errors and omissions. We hope you will appreciate that no claims can be entertained on the basis of the data, illustrations or descriptions in this manual.



## General views

General view, left side .....	11
General view, right side .....	13
Underneath the seat .....	14
Underneath the trim panel .....	15
Multifunction switch, left .....	16
Multifunction switch, right .....	17
Instrument panel .....	18



## General view, left side

- 1 Power socket (→ 94)
- 2 Seat lock (→ 58)
- 3 Engine-oil filler neck and oil dipstick (→ 105)

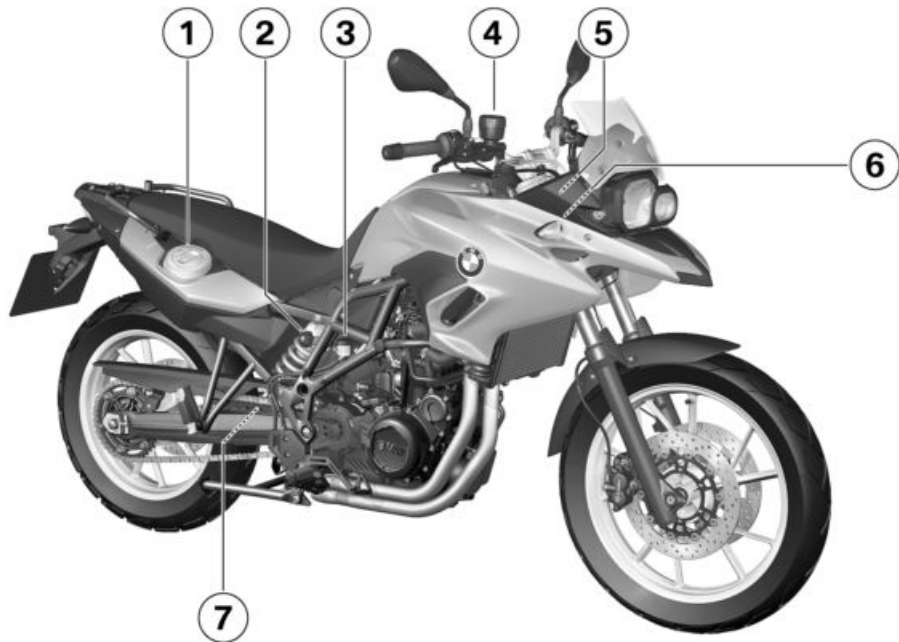

## General view, right side

- 1 Fuel filler neck (▣▣▣ 83)
- 2 Adjuster, spring preload (▣▣▣ 52)
- 3 Brake-fluid reservoir, rear (▣▣▣ 110)
- 4 Brake-fluid reservoir, front (▣▣▣ 109)
- 5 VIN, type plate (on steering-head bearing)
- 6 Coolant level indicator (behind side panel) (▣▣▣ 111)
- 7 Adjuster for damping characteristic (▣▣▣ 53)

## Underneath the seat

- 1 Stowage  
– with first-aid kit<sup>OA</sup>  
Location of the first-aid kit
- 2 Standard tool kit (►► 104)
- 3 Payload table
- 4 Table of tyre pressures
- 5 Helmet holder (►► 58)
- 6 Rider's Manual (in rear of vehicle)  
– with alarm system  
(DWA)<sup>OE</sup>  
Rider's Manual (below control unit) (►► 59)
- 7 Tool for adjusting spring preload (►► 52)

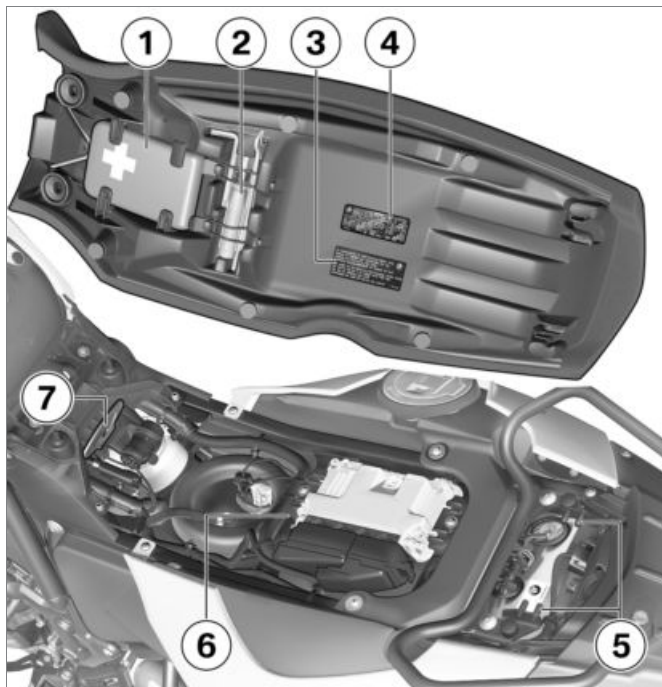

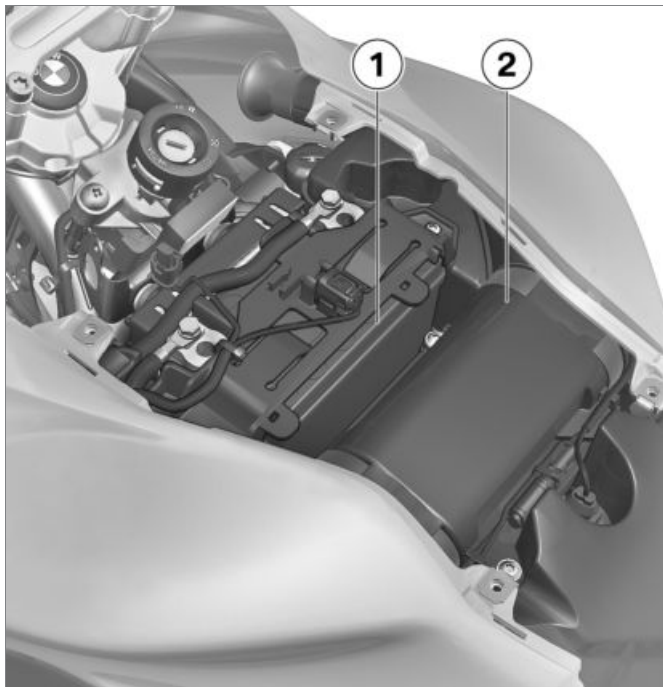

## Underneath the trim panel

- 1 Battery (➡ 133)
- 2 Air-filter housing (➡ 131)

## Multifunction switch, left

- 1 High-beam headlight and headlight flasher (→ 45)
- 2 Select display (→ 42).  
– with on-board computer<sup>OE</sup>  
Resetting the average values (→ 43).
- 3 Hazard warning flashers (→ 46)
- 4 Operation of the flashing turn indicators (→ 46)
- 5 Horn
- 6 – with Electronic Suspension Adjustment (ESA)<sup>OE</sup>  
Operating ESA (→ 55)
- 7 Operating the ABS (→ 48)  
– with Automatic Stability Control (ASC)<sup>OE</sup>  
Operating the ASC (→ 49)

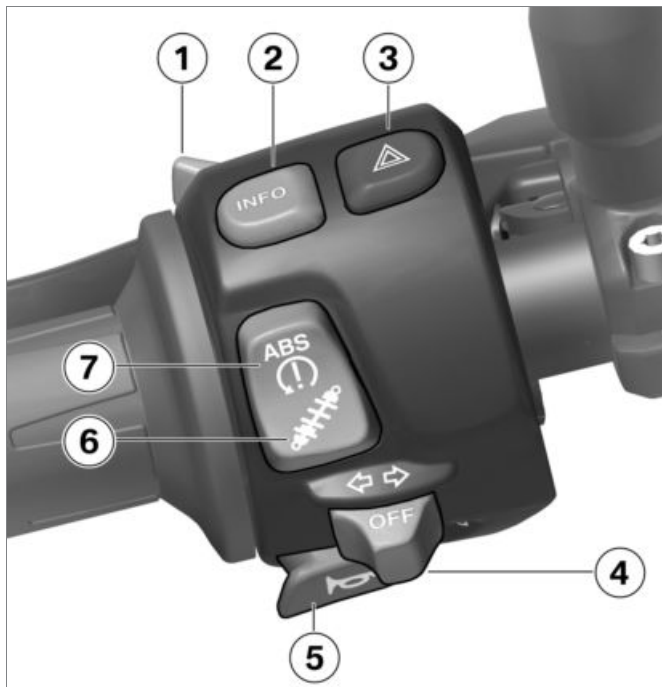



## Multifunction switch, right

- 1 – with heated handlebar grips<sup>OE</sup>  
Grip heating control (→ 47)
- 2 Starter button (→ 76)
- 3 Emergency off switch (kill switch) (→ 47)

## Instrument panel

- 1 Warning and telltale lights (►► 24)
- 2 Speedometer
- 3 Setting clock (►► 41).  
– with on-board computer<sup>OE</sup>  
Operation of the stopwatch (►► 43)
- 4 Multifunction display (►► 22)
- 5 Select display (►► 42).  
Resetting tripmeter (►► 43).

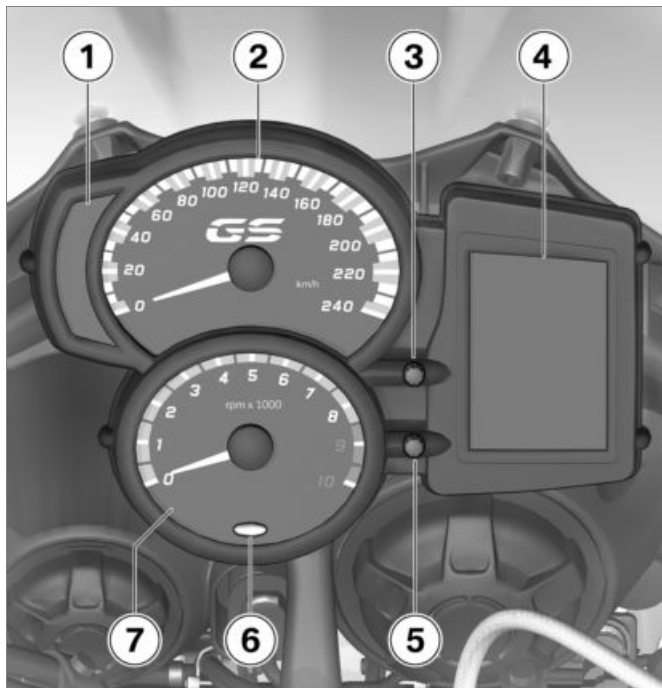

- 6** Ambient-light brightness sensor (for adapting the brightness of the instrument lighting)
- with alarm system (DWA)<sup>OE</sup>
- Anti-theft alarm telltale light (see the instructions for use for the anti-theft alarm)
- with on-board computer<sup>OE</sup>
- Redline warning (▣▣▣▣▶ 79)
- 7** Rev. counter



## Status indicators

Multifunction display .....	22
Meaning of symbols .....	23
Warning and telltale lights.....	24
Fuel level .....	25
Fuel reserve .....	25
Service-due indicator .....	25
Ambient temperature .....	26
Tyre pressures.....	26
Warnings .....	27

## Multifunction display

- 1 Warning for engine electronics (►► 33)
- 2 – with heated handlebar grips<sup>OE</sup>  
Display showing chosen level of grip heating (►► 47)
- 3 – with on-board computer<sup>OE</sup>  
Stopwatch (►► 43)
- 4 Time (►► 41)
- 5 – with tyre pressure monitoring (RDC)<sup>OE</sup>  
Tyre pressures (►► 26)
- 6 Warning for coolant temperature (►► 32)
- 7 Service due (►► 25)
- 8 Values area (►► 42)
- 9 – with on-board computer<sup>OE</sup>  
Symbols explaining the readings shown in the values area (►► 23)

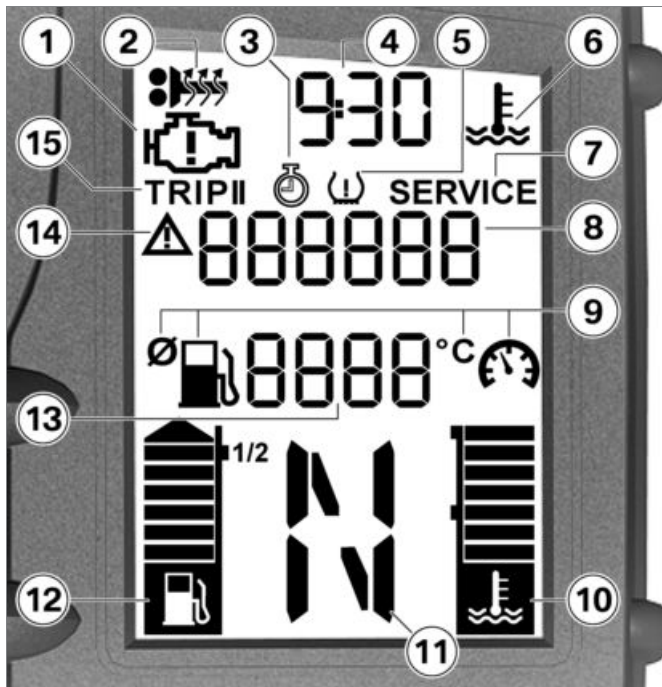

- 10** Coolant temperature display
- 11** – with on-board computer (OE)  
Gear indicator; "N" indicates neutral
- 12** Fuel level (▬▬▬▶ 25)
- 13** – with on-board computer (OE)  
Values area (▬▬▬▶ 42)
- 14** a warning is shown in the values area (▬▬▬▶ 27)
- 15** Trip meter (▬▬▬▶ 42)

## Meaning of symbols

– with on-board computer<sup>OE</sup>



Distance travelled after fuel down to reserve (▬▬▬▶ 25)



Average consumption



Average speed



Current consumption



Ambient temperature (▬▬▬▶ 26)

## Warning and telltale lights

- 24
- 1 ABS warning light (➡ 34)
  - 2 – with Automatic Stability Control (ASC)<sup>OE</sup>
  - ASC warning light (➡ 35)
  - 3 Warning light for fuel down to reserve (➡ 25) (➡ 32)
  - 4 General warning light, in combination with warnings in the display (➡ 27)
  - 5 High-beam headlight telltale light
  - 6 Telltale light for right turn indicators
  - 7 Telltale light for neutral
  - 8 Telltale light for left turn indicators



### NOTICE

The ABS symbol might differ, depending on the specifics of national regulations. ◀



## Fuel level

Due to the complex shape of the fuel tank, it is impossible to determine the fuel level when the tank is approaching capacity. For this reason, the fill-level indicator only displays the bottom half of the filling capacity in detail.

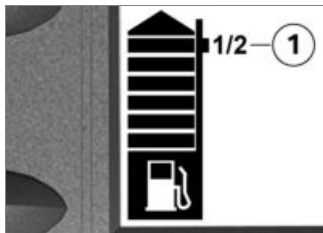

If the fill-level indicator reaches the 1/2-mark **1**, the fuel tank is half-full. From then on, the fill-level will be displayed more precisely.

If the fuel reserve is reached, the fuel warning light will come on.

## Fuel reserve

The amount of fuel present in the fuel tank when the fuel warning light is switched on is dependent on vehicle dynamics. The more the fuel moves inside the tank (due to regularly changing angles of heel, frequent braking and acceleration), the more difficult it becomes to determine the reserve volume. For this reason, the fuel reserve volume cannot be displayed exactly.

– with on-board computer<sup>OE</sup>



After the fuel warning light comes on, the distance that has travelled since this time is displayed.

The distance that can still be travelled using the reserve volume depends on the style of driving (usage) and the amount of fuel remaining at the time the light came on.

The odometer for the fuel reserve is reset when the amount of fuel is greater than the reserve volume.

## Service-due indicator



If the next service is due in less than one month, the date for the next service **1** is shown briefly after the Pre-Ride Check completes. The month and year are displayed with two and four digits respectively, separated by a colon. In the example, the display represents “June 2014”.



If the vehicle covers long distances in the course of the year, under certain circumstances it might be necessary to have it serviced at a date in advance of the forecast due date. When the countdown distance to the odometer reading at which a service is due drops below 1000 km, the distance is counted down in steps of 100 km **1** and is shown briefly after the Pre-Ride Check completes.



If service is overdue, the due date or the odometer reading at which service was due

is accompanied by the 'General' warning light showing yellow. The word "Service" remains permanently visible.



## NOTICE

If the service-due indicator appears more than a month before the service date, the date saved in the instrument cluster must be adjusted. This situation can occur if the battery was disconnected for a prolonged period of time.

If you want to have the date set consult a specialist workshop, preferably an authorised BMW Motorrad dealer. ◀

## Ambient temperature

– with on-board computer<sup>OE</sup>



When the motorcycle is at a standstill the heat of the engine can falsify the ambient-temperature reading. If the effect

of the engine's heat becomes excessive, – temporarily appears on the display.

If ambient temperature drops below 3 °C the temperature display flashes to draw your attention to the risk of black ice forming. The display automatically switches from any other mode to the temperature reading when the temperature drops below this threshold for the first time.

## Tyre pressures

– with tyre pressure monitoring (RDC)<sup>OE</sup>

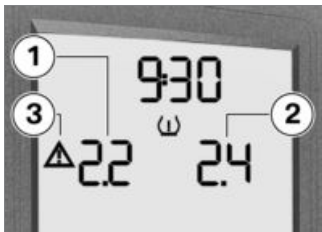

The tyre-pressure readings are based on a reference tyre temperature of 20 °C. The front tyre pressure is on the left **1**; the reading on the right **2** is the rear tyre pressure. "-- --" appears directly after the ignition is switched on, because the sensors do not transmit tyre pressures until the first time the motorcycle accelerates to more than 30 km/h.

 If warning triangle **3** also shows, the reading is a warning. The critical pressure flashes.

If the critical value is close to the limit of the permissible tolerance range, the 'General' warning light shows yellow. If the tyre pressure registered by the sensor is outside the permissible tolerance range, the 'General' warning light flashes red.

The detailed description of BMW Motorrad RDC starts on page (➡ 91).

## Warnings

### Mode of presentation

Warnings are indicated by the corresponding warning lights.

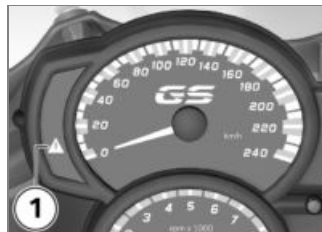

Warnings that do not have warning lights of their own are indicated by 'general' warning light **1** showing in combination with a text warning or a warning symbol in the multifunction display. The 'General' warning light shows red or yellow, depending on the urgency of the warning.

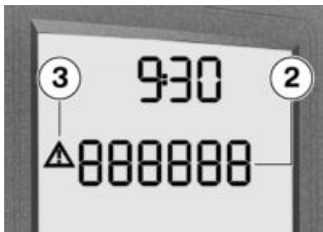

A reading in values area **2** that constitutes a warning is accompanied by warning triangle **3**. These warnings can alternate with the odometer readings (▬▶ 42).

The status of the 'General' warning light matches the most urgent warning.













The possible warnings are listed on the next page.

## Warnings, overview

### Warning and telltale lights











### Warning symbols in the display

### Meaning

 lights up yellow	 + "EWS" appears on the display	Electronic immobiliser active (→ 32)
 lights up		Fuel down to reserve (→ 32)
 lights up red	 flashes	Coolant temperature too high (→ 32)
 lights up yellow	 appears on the display	Engine in emergency-operation mode (→ 33)
 lights up yellow	 + "LAMP" appears on the display	Bulb defective (→ 33)
	"x . x °C" flashes	Outside temperature warning (→ 34)
 lights up yellow	 + "DWA" appears on the display	DWA battery flat (→ 34)
 flashes		ABS self-diagnosis not completed (→ 34)

## Warning and telltale lights









## Warning symbols in the display

Warning and telltale lights		Warning symbols in the display	Meaning
	lights up		ABS deactivated (→ 34)
	lights up		ABS fault (→ 35)
	quick-flashes		ASC intervention (→ 35)
	slow-flashes		ASC self-diagnosis not completed (→ 35)
	lights up		ASC deactivated (→ 35)
	lights up		ASC fault (→ 36)
	lights up yellow	 + "x . x" flashes	Tyre pressure close to limit of permitted tolerance (→ 36)
	flashes red	 + "x . x" flashes	Tyre pressure outside permitted tolerance (→ 36)

## Warning and telltale lights

## Warning symbols in the display

## Meaning

		+ "--" or "-- - -" appears on the display.	Signal transmission disrupted (  37)
 lights up yellow		+ "--" or "-- - -" appears on the display.	Sensor defective or system error (  38)
 lights up yellow		+ "RdC" appears on the display.	Battery of tyre-pressure sensor weak (  38)

## Electronic immobiliser active



General warning light shows yellow.



+ "EWS" appears on the display.

Possible cause:

The key being used is not authorised for starting, or communication between key and engine electronics is disrupted.

- Remove all other vehicle keys from the same ring as the ignition key.
- Use the reserve key.
- Have the defective key replaced, preferably by an authorised BMW Motorrad dealer.

## Fuel down to reserve



Warning light for fuel down to reserve shows.



## WARNING

### Irregular engine operation or engine shutdown due to lack of fuel.

Risk of accident. Damage to catalytic converter.

- Do not run the fuel tank dry. ◀

Possible cause:

The fuel tank contains no more than the reserve quantity of fuel.



Reserve fuel

min 2.7 l

- Refuelling (▣ 83).

### Coolant temperature too high



General warning light shows red.



Temperature symbol flashes.



## ATTENTION

### Riding with overheated engine.

Engine damage

- Compliance with the information set out below is essential. ◀

Possible cause:

If the coolant level is too low.

- Checking coolant level (▣ 111).

If the coolant level is too low:

- Topping up coolant (▣ 111).

Possible cause:

The coolant temperature is too high.

- If possible, ride in the part-load range to cool down the engine.
- In traffic jams, switch off the engine, but leave the ignition switched on so that the radiator fan continues to operate.

- If the coolant temperature is frequently too high, have the fault rectified as soon as possible by a specialist workshop, preferably an authorised BMW Motorrad dealer.

### Engine in emergency-operation mode



General warning light shows yellow.



Engine symbol appears on the display.



### WARNING

### Unusual ride characteristics when engine running in emergency-operation mode.

Risk of accident

- Adapt your style of riding accordingly.
- Avoid accelerating sharply and overtaking. ◀

Possible cause:

The engine control unit has diagnosed a fault. In exceptional cases, the engine stops and refuses to start. Otherwise, the engine runs in emergency operating mode.

- You can continue to ride, but bear in mind that the usual engine performance might not be available.
- Have the fault rectified as quickly as possible by a specialist workshop, preferably an authorised BMW Motorrad dealer.

### Bulb defective



General warning light shows yellow.



+ "LAMP" appears on the display.



### WARNING

### Failure of lights on the vehicle adds to possibility of other road users overlooking the vehicle.

Safety risk

- Replace defective bulbs as soon as possible; always carry a complete set of spare bulbs if possible. ◀

Possible cause:

Bulb defective.

- Visually inspect to ascertain which bulb is defective.
- Replacing low-beam and high-beam headlight bulb (►► 124).
- Replacing parking-light bulb (►► 125).
- Replacing LED for brake light and tail light (►► 127).
- Replacing bulbs for front and rear turn indicators (►► 127).

## Outside temperature warning

– with on-board computer<sup>OE</sup>

"x . x °C" (ambient temperature) flashes.

Possible cause:

The air temperature measured at the motorcycle is lower than 3 °C.



### WARNING

**Risk of black ice forming at temperatures above 3 °C, even though no ambient-temperature warning is issued.**

Risk of accident due to icy surface.

- Always take extra care when temperatures are low; remember that there is particular danger of black ice forming on bridges and where the road is in shade.◀

- Ride carefully and think well ahead.

## DWA battery flat

– with alarm system (DWA)<sup>OE</sup>



General warning light shows yellow.



+ "DWA" appears on the display.



### NOTICE

This error message shows briefly only after the Pre-Ride-Check completes.◀

Possible cause:

The integral battery in the anti-theft alarm has lost its entire original capacity. There is no assurance that the anti-theft alarm will be operational if the vehicle's battery is disconnected.

- Seek the advice of a specialist workshop, preferably an authorised BMW Motorrad dealer.

## ABS self-diagnosis not completed



ABS telltale and warning light flashes.

Possible cause:

The ABS function is not available, because self-diagnosis did not complete. The motorcycle has to move forward a few metres for the wheel sensors to be tested.

- Pull away slowly. Bear in mind that the ABS function is not available until self-diagnosis has completed.

## ABS deactivated



ABS telltale and warning light shows.

Possible cause:

The rider has switched off the ABS system.

- Activate ABS function (▣▣▣▣▶ 49).

## ABS fault



ABS telltale and warning light shows.

Possible cause:

The ABS control unit has detected a fault.

- You can continue to ride. Bear in mind that the ABS function is not available. Bear in mind the more detailed information on certain situations that can lead to ABS fault messages (▣▣▣▣▶ 89).
- Have the fault rectified as quickly as possible by a specialist workshop, preferably an authorised BMW Motorrad dealer.

## ASC intervention

– with Automatic Stability Control (ASC)<sup>OE</sup>



ASC telltale and warning light quick-flashes.

The ASC has detected a degree of instability at the rear wheel and has intervened to reduce torque. The warning light flashes for longer than ASC intervention lasts. This affords the rider visual feedback on control intervention even after the critical situation has been dealt with.

## ASC self-diagnosis not completed

– with Automatic Stability Control (ASC)<sup>OE</sup>



ASC telltale and warning light slow-flashes.

Possible cause:

Self-diagnosis did not complete, so the ASC function is not available. The engine must be running and the motorcycle must reach a speed of at least 5 km/h) in order for ASC self-diagnosis to complete.

- Pull away slowly. Bear in mind that the ASC function is not available until self-diagnosis has completed.

## ASC deactivated

– with Automatic Stability Control (ASC)<sup>OE</sup>



ASC telltale and warning light shows.

Possible cause:

The rider has switched off the ASC system.

- Activate ASC

## ASC fault

– with Automatic Stability Control (ASC)<sup>OE</sup>



ASC telltale and warning light shows.

Possible cause:

The ASC control unit has detected a fault. The ASC function is not available.

- You can continue to ride. Bear in mind that the ASC function is not available. Bear in mind the more detailed information on situations that can lead to an ASC fault (►► 90).
- Have the fault rectified as quickly as possible by a specialist workshop, preferably an authorised BMW Motorrad dealer.

## Tyre pressure close to limit of permitted tolerance

– with tyre pressure monitoring (RDC)<sup>OE</sup>



General warning light shows yellow.



+ "x . x" (critical pressure) flashes.

Possible cause:

Measured tyre pressure is close to the limit of permitted tolerance.

- Correct the tyre pressure as stated on the inside cover of the Rider's Manual.



### NOTICE

Before you adjust tyre pressure, read the information on temperature compensation and adjusting pressure in the section entitled "Engineering details". ◀

## Tyre pressure outside permitted tolerance

– with tyre pressure monitoring (RDC)<sup>OE</sup>



General warning light flashes red.



+ "x . x" (critical pressure) flashes.

Possible cause:

Measured tyre pressure is outside permitted tolerance.

- Check the tyre for damage and to ascertain whether the vehicle can be ridden with the tyre in its present condition. If the vehicle can be ridden with the tyre in its present condition:



### WARNING

## Tyre pressure outside permitted tolerance.

Impairment of the vehicle's handling characteristics.

- Adapt your style of riding accordingly. ◀
- Correct the tyre pressure at the earliest possible opportunity.
- Have the tyre checked for damage by a specialist workshop, preferably an authorised BMW Motorrad dealer.

If you are unsure whether the vehicle can be ridden with the tyre in its present condition:

- Do not continue your journey.
- Notify the breakdown service.
- Have the tyre checked for damage by a specialist workshop, preferably an authorised BMW Motorrad dealer.

## Signal transmission disrupted

– with tyre pressure monitoring (RDC)<sup>OE</sup>



+ "---" or "--- ---" appears on the display.

Possible cause:

The vehicle has not yet accelerated past the threshold of approximately 30 km/h. The RDC sensors do not start transmitting signals until the motorcycle reaches a speed above this threshold (▬► 91).

- Increase speed above this threshold and observe the RDC readings. Assume that a permanent fault has not occurred unless the 'General' warning light comes on to accompany the symptoms.

Under these circumstances:

- Have the fault rectified by a specialist workshop, preferably an authorised BMW Motorrad dealer.

Possible cause:

Wireless communication with the RDC sensors has been disrupted. Possible causes include radio-communication systems operating in the vicinity and interfering with the link between the RDC control unit and the sensors.

- Move to another location and observe the RDC readings. Assume that a permanent fault has not occurred unless the 'General' warning light comes on to accompany the symptoms.

Under these circumstances:

- Have the fault rectified by a specialist workshop, preferably an authorised BMW Motorrad dealer.

## Sensor defective or system error

– with tyre pressure monitoring (RDC)<sup>OE</sup>



General warning light shows yellow.



+ "---" or "--- ---" appears on the display.

Possible cause:

Motorcycle is fitted with wheels not equipped with RDC sensors.

- Fit wheels and tyres equipped with RDC sensors.

Possible cause:

1 or 2 RDC sensors have failed.

- Have the fault rectified by a specialist workshop, preferably an authorised BMW Motorrad dealer.

Possible cause:

A system error has occurred.

- Have the fault rectified by a specialist workshop, preferably an authorised BMW Motorrad dealer.

## Battery of tyre-pressure sensor weak

– with tyre pressure monitoring (RDC)<sup>OE</sup>



General warning light shows yellow.



+ "RdC" appears on the display.



### NOTICE

This error message shows briefly only after the Pre-Ride-Check completes. ◀

Possible cause:

The tyre-pressure battery is almost at full capacity. There is no assurance of how long the tyre pressure control system can remain operational.

- Seek the advice of a specialist workshop, preferably an authorised BMW Motorrad dealer.

## Operation

Ignition switch .....	40	Mirrors .....	52
Electronic immobiliser .....	41	Spring preload .....	52
Clock .....	41	Damping .....	53
Reading .....	42	Electronic Suspension Adjustment ESA .....	55
Stopwatch .....	43	Tyres .....	56
Lights .....	45	Headlight .....	57
Turn indicators .....	46	Seat .....	58
Hazard warning flashers .....	46	Helmet holder .....	58
Emergency off switch (kill switch) .....	47	Rider's Manual .....	59
Grip heating .....	47		
BMW Motorrad ABS .....	48		
BMW Motorrad ASC .....	49		
Clutch .....	50		
Brakes .....	51		

## Ignition switch

### Keys

You receive 2 ignition keys. Please consult the information on the electronic immobiliser (EWS) if a key is lost or mislaid (►► 41). Ignition switch, fuel filler cap lock and seat lock are all operated with the same key.

- with cases<sup>OA</sup>
- with topcase<sup>OA</sup>

If you wish you can arrange to have the cases and the topcase fitted with locks that can be opened with this key as well. Consult a specialist workshop, preferably an authorised BMW Motorrad dealer.

### Switching on ignition

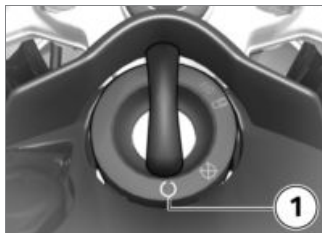

- Turn the key to position **1**.
  - » Parking lights and all function circuits switched on.
  - » Engine can be started.
  - » Pre-ride check is performed (►► 76)
  - » ABS self-diagnosis is in progress. (►► 77)
- with Automatic Stability Control (ASC)<sup>OE</sup>
  - » ASC self-diagnosis is performed. (►► 78)◀

### Switch off the ignition



- Turn the key to position **2**.
  - » Lights switched off.
  - » Handlebars not locked.
  - » Key can be removed.
  - » Electrically powered accessories remain operational for a limited period of time.
  - » The battery can be recharged via the on-board socket.

### Locking handlebars

- Turn the handlebars all the way to left



engine to be started if the key is identified as “authorised”.

### NOTICE

A spare key attached to the same ring as the ignition key used to start the engine could “irritate” the electronics, in which case the enabling signal for starting is not issued. The EWS warning appears in the multifunction display.

Always keep the spare key separately from the ignition key. ◀

If you lose a key, you can have it barred by your authorised BMW Motorrad dealer. If you wish to do this, you will need to bring all other keys for the motorcycle with you.

The engine cannot be started by a barred key, but a key that has been barred can subsequently be reactivated.

- Turn the key to position **3**, while moving the handlebars slightly.
- » Ignition, lights and all function circuits switched off.
- » Handlebars locked.
- » Key can be removed.

## Electronic immobiliser

The electronic design of the motorcycle allows it to access data stored in the ignition key by means of a ring antenna located in the ignition switch. The engine control unit will only allow the en-

You can obtain emergency/extra keys only through an authorised BMW Motorrad dealer. The keys are part of an integrated security system, so the dealer is under an obligation to check the legitimacy of all applications for replacement/extra keys.

## Clock

### Setting clock

### WARNING

#### Adjusting the clock while riding.

Risk of accident

- Set the clock only when the motorcycle is stationary. ◀
- Switch on the ignition.

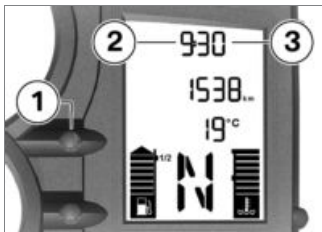

- Press and hold down button **1** until the hours number **2** flashes.
  - Repeatedly press the button until the hours number is correct.
  - Press and hold down the button until the minutes number **3** flashes.
  - Repeatedly press the button until the minutes number is correct.
  - Hold down the button until the minutes number stops flashing.
- » This completes the process.

## Reading

### Select display

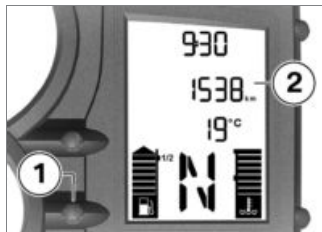

- Switch on the ignition.



- Press button **1** to select the reading in values area **2**.
- The following values can be displayed:
- Odometer (shown)
  - Tripmeter 1 (Trip I)
  - Tripmeter 2 (Trip II)
- with tyre pressure monitoring (RDC)<sup>OE</sup>  
Tyre pressures<

- Warnings, if applicable
- with on-board computer<sup>OE</sup>



- Press button **1** to select the reading in values area **2**.
- The following values can be displayed:
- Ambient temperature (°C)
-  Average speed in km/h
-  Average consumption in l/100 km
-  Current consumption in l/100 km



distance travelled after fuel down to reserve in km◁

## Resetting tripmeter

- Switch on the ignition.
- Select the desired tripmeter.



- Press and hold down button **1** until the tripmeter reading is reset.

## Resetting the average values

- with on-board computer<sup>OE</sup>
- Switch on the ignition.

- Select average consumption or average speed.



- Press and hold down button **1** until the value shown is reset.

## Stopwatch

- with on-board computer<sup>OE</sup>

## Stopwatch

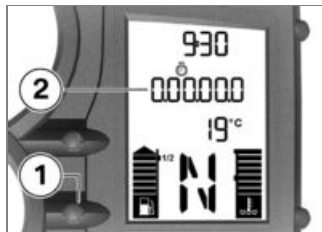

You can switch from the odometer reading to a stopwatch **2**. The readout is in hours, minutes, seconds and tenths of a second, with dots as separators. By swapping the functions of button **1** and the INFO button on the handlebar fitting you can make the stopwatch easier to use (as a lap timer) as you ride. If you swap the functions in this way the stopwatch and the odometer are operated by means of the INFO button and you must

use button **1** to operate the on-board computer.

The stopwatch continues to time in the background if you switch back temporarily to the odometer reading. Similarly, the stopwatch continues timing if you temporarily switch off the ignition.

### Operating stopwatch

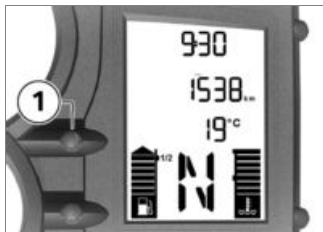

- If necessary, use button **1** to switch from the odometer to the stopwatch.

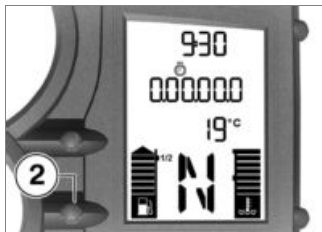

- When the stopwatch is stopped, press button **2** to start timing with the stopwatch.
- When the stopwatch is running, press button **2** to stop timing with the stopwatch.
- Press and hold down button **2** to reset the stopwatch.

### Changing button functions

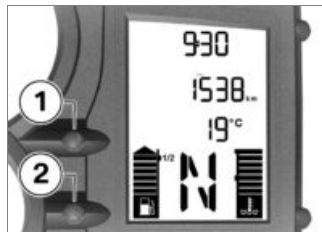

- Press button **1** and button **2** at the same time and hold them down until the reading changes.
  - » FLASH (redline warning) appears, along with ON or OFF.
- Press button **2**.
  - » LAP (Lap-Timer) and ON or OFF appear.
- Repeatedly press button **1** until the reading shows the mode you want.

- » ON: Stopwatch operated by means of the INFO button on the handlebar fitting.
- » OFF: Stopwatch operated by means of button **2** in the instrument panel.
- To save the setting, press button **1** and button **2** at the same time and hold them down until the reading changes.

## Lights

### Side light

The side lights switch on automatically when the ignition is switched on.

#### NOTICE

The side lights place a strain on the battery. Do not switch the ignition on for longer than absolutely necessary.◀

### Low-beam headlight

The low-beam headlight comes on automatically under the following conditions:

- If the engine is started
- If the vehicle is pushed while the ignition is on.

#### NOTICE

When the engine is not running you can switch on the lights by switching on the ignition and either switching on the high-beam headlight or operating the headlight flasher.◀

### High-beam headlight and headlight flasher



- Push switch **1** forward to switch on the high-beam headlight.
- Pull switch **1** back to operate the headlight flasher.

### Parking light

- Switch off the ignition.



- Immediately after switching off the ignition, push button **1** to the left and hold it in this position until the parking lights come on.
- Switch the ignition on and off again to switch off the parking lights.

## Turn indicators

### Operating the turn indicators

- Switch on the ignition.



### NOTICE

The turn indicators are cancelled automatically after the defined time and distance. The defined time and distance can be set by an authorised BMW Motorrad dealer. ◀



- Push button **1** to the left to switch on the left turn indicators.
- Push button **1** to the right to switch on the right turn indicators.

- Operate centre button **1** to cancel the turn indicators.

## Hazard warning flashers

### Operate hazard warning flashers

- Switch on the ignition.



### NOTICE

The hazard warning flashers place a strain on the battery. Do not use the hazard warning flashers for longer than absolutely necessary. ◀



### NOTICE

If you press a turn-indicator button with the hazard warning flashers switched on, the turn-indicator function is activated instead of the hazard warning flashers, and remains active until you release the button.

The hazard warning flashers recommence flashing as soon as the button is released.◀



- Press button **1** to switch on the hazard warning flashers.  
» Ignition can be switched off.
- Press button **1** again to switch off the hazard warning flashers.

## Emergency off switch (kill switch)



- 1** Emergency off switch (kill switch)



### WARNING

#### Operation of the kill switch while riding.

Risk of fall due to rear wheel locking.

- Do not operate the kill switch when riding.◀

The emergency off switch is a kill switch for switching off the engine quickly and easily.



- a** Engine switched off  
**b** Normal operating position (run)

## Grip heating

– with heated handlebar grips<sup>OE</sup>

### Operating grip heating

- Start the engine.

## NOTICE

The heating in the heated handlebar grips can be activated only when the engine is running. ◀

## NOTICE

The increase in power consumption caused by having the heated handlebar grips switched on can drain the battery if you are riding at low engine speeds. If the charge level is low, the heated handlebar grips are switched off to ensure the battery's starting capability. ◀



- Repeatedly press button **1** until the desired heating stage appears on the display.



The handlebar grips have two-stage heating. Stage two **2** is for heating the grips quickly: it is advisable to switch back to

stage one as soon as the grips are warm.



50 % heating power



100 % heating power

- » The selected heating stage will be saved if you allow a certain length of time to pass without making further changes.

## **BMW Motorrad ABS** **Deactivate ABS function**

- Bring the motorcycle to a stop or, if the motorcycle is at a standstill, switch on the ignition.



- Press and hold down button **1** until the ABS warning light changes status.

 ABS telltale and warning light shows.

– with Automatic Stability Control (ASC)<sup>OE</sup>

- » Initially, the ASC symbol changes status. Press and hold down button **1** until the ABS warning light responds. Under these circumstances there is no change in the ASC setting.◀

- Release button **1** within two seconds.

 ABS telltale and warning light remains on.

- » The ABS function is deactivated.

### Activate ABS function



- Press and hold down button **1** until the ABS warning light changes status.

 ABS telltale and warning light goes out; if self-diagnosis has not completed it starts flashing.

- Release button **1** within two seconds.

 ABS telltale and warning light remains off or continues to flash.

- » The ABS function is activated.
- You also have the option of switching the ignition off and then on again.



### NOTICE

An ABS fault has occurred if the ABS telltale and warning light shows when the motorcycle accelerates to a speed in excess of 5 km/h after the ignition was switched off and then on again.◀

### BMW Motorrad ASC

– with Automatic Stability Control (ASC)<sup>OE</sup>

### Deactivate ASC function

- Switch on the ignition.



## NOTICE

You have the option of deactivating the ASC function while the motorcycle is on the move. ◀



- Press and hold down button **1** until the ASC warning light changes status.



ASC telltale and warning light shows.

- Release button **1** within two seconds.



ASC telltale and warning light remains on.

» The ASC function is deactivated.

## Activate ASC function



- Press and hold down button **1** until the ASC warning light changes status.



ASC telltale and warning light goes out; if self-diagnosis has not completed it starts flashing.

- Release button **1** within two seconds.



ASC telltale and warning light remains off or continues to flash.

» The ASC function is activated.

- You also have the option of switching the ignition off and then on again.



## NOTICE

An ASC fault has occurred if the ASC telltale and warning light shows when the motorcycle accelerates to a speed in excess of 5 km/h after the ignition was switched off and then on again. ◀

## Clutch

### Adjusting clutch lever



## WARNING

### Adjusting the clutch lever while riding.

Risk of accident

- Do not attempt to adjust the clutch lever unless the motorcycle is at a standstill. ◀

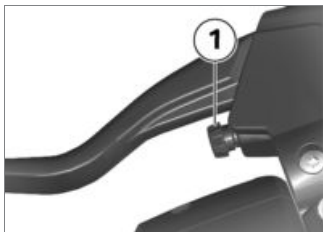

## Brakes

### Adjust the handbrake lever

#### WARNING

#### Changed position of the brake fluid reservoir.

Air in the brake system.

- Do not turn the handlebars or the handlebar fitting on the handlebar. ◀

#### WARNING

#### Adjusting the brake lever while riding.

Risk of accident

- Do not attempt to adjust the brake lever unless the motorcycle is at a standstill. ◀

#### NOTICE

The adjusting screw is easier to turn if you push the clutch lever forward. ◀

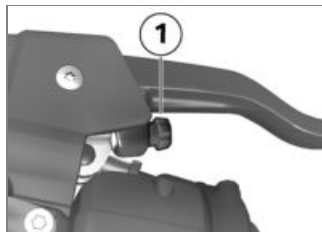

- Turn adjusting screw **1** clockwise to increase the span between the brake lever and the handlebar grip.
- Turn adjusting screw **1** counter-clockwise to reduce the span between the brake lever and the handlebar grip.

#### NOTICE

The adjusting screw is easier to turn if you push the brake lever forward. ◀

## Mirrors

### Adjusting mirrors



- Turn the mirror to the desired position.

### Adjusting mirror arm



- Push protective cap **1** up over the threaded fastener on the mirror arm.
- Slacken nut **2**.
- Turn the mirror arm to the appropriate position.
- Tighten the nut to the specified tightening torque, while holding the mirror arm to ensure that it does not move out of position.



Locknut (mirror) to clamping piece

Joining compound: Multi-wax spray

20 Nm

- Push the protective cap over the threaded fastener.

## Spring preload

### Setting

It is essential to set spring preload of the rear suspension to suit the load carried by the motorcycle. Increase spring preload when the motorcycle is heavily loaded and reduce spring preload accordingly when the motorcycle is lightly loaded.

### Adjust spring preload for rear wheel

- Removing seat (➡ 58).

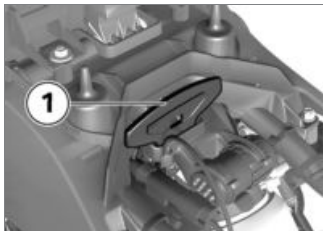

- Remove on-board toolkit **1**.



**⚠ WARNING**

**Spring preload setting and spring-strut damping setting not matched.**

Impaired handling.

- Adjust spring-strut damping to suit spring preload.◀
- If you want to increase spring preload, use the tool from the on-board toolkit to turn knob **2** clockwise.
- If you want to reduce spring preload, use the tool from the on-board toolkit to turn knob **2** counter-clockwise.



Basic setting of spring preload, rear

Turn the dial counter-clockwise as far as it will go (One-up riding without luggage)

Turn the dial counter-clockwise as far as it will go, then make 12 clockwise rotations (One-up riding with luggage)

Turn the dial clockwise as far as it will go (Passenger operation with luggage)



Basic setting of spring preload, rear

– with lowered suspension<sup>OE</sup>

Turn the adjuster as far as it will go counter-clockwise, then back it off 5 clicks (One-up riding without luggage)◀

- Stow the on-board toolkit in its correct position.
- Installing seat (☛ 58).

## Damping Setting

Damping must be adapted to suit the condition of the surface on which the motorcycle is ridden and to suit spring preload.

- An uneven surface requires softer damping than a smooth surface.
- An increase in spring preload requires firmer damping, a reduction in spring preload requires softer damping.

## Adjust the damping for rear wheel

- Make sure the ground is level and firm and place the motorcycle on its stand.



- Adjust the damping characteristic by turning adjusting screw **1**.

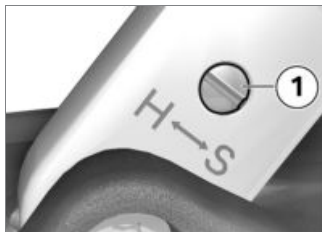

- If you want a harder damping characteristic, turn adjusting screw **1** in the direction indicated by the H arrow.
- If you want a softer damping characteristic, turn adjusting screw **1** in the direction indicated by the S arrow.

 Basic setting of rear-suspension damping characteristic

– without Electronic Suspension Adjustment (ESA)<sup>OE</sup>

 Basic setting of rear-suspension damping characteristic

Turn the adjusting screw as far as it will go in the clockwise direction and then back it off one and a half turns (One-up without luggage)

Turn the adjusting screw as far as it will go in the clockwise direction and then back it off one and a half turns (One-up with luggage)

Turn the adjusting screw as far as it will go in the clockwise direction and then back it off 1 turn (Two-up with luggage) <

## Electronic Suspension Adjustment ESA

– with Electronic Suspension Adjustment (ESA)<sup>OE</sup>

### Possible settings

With the help of Electronic Suspension Adjustment (ESA), you can calibrate the rear-wheel damping to the terrain with ease. Three settings are available for damping.

### Call up settings

- Switch on the ignition.



- Press button **1** to view the current setting.

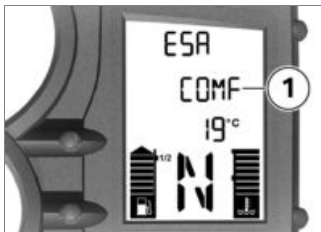

The currently selected damping is shown on the multifunction display at **1**. The meanings of the readings are as follows:

- COMF Comfortable damping characteristic
- NORM Normal damping characteristic
- SPORT Sporty damping characteristic

» The setting shows briefly, then disappears automatically.

### Adjust the chassis and suspension

- Switch on the ignition.



- Press button **1** to view the current setting.

To make different adjustment to the damping:

- Repeatedly press button **1** until the setting you want to use appears on the display.



### NOTICE

You can adjust the damping characteristic while the motorcycle is on the move. ◀

- » The setting shown on the display is automatically accepted as the damping characteristic if you allow a certain length of time to pass without pressing button **1**.
- » The ESA indicator disappears from the display as soon as adjustment completes.

## Tyres

### Checking tyre pressure



#### WARNING

#### Incorrect tyre pressure.

Impairment of the motorcycle's handling characteristics. Shorter useful tyre life.

- Always check that the tyre pressures are correct. ◀



#### WARNING

#### Tendency of valve inserts installed vertically top open by themselves at high riding speeds.

Sudden loss of tyre pressure.

- Install valve caps fitted with rubber sealing rings and tighten firmly. ◀
- Make sure the ground is level and firm and place the motorcycle on its stand.

- Check tyre pressures against the data below.



Tyre pressure, front

2.2 bar (one-up, tyre cold)

2.2 bar (two-up and/or with luggage, tyre cold)



Tyre pressure, rear

2.5 bar (one-up, tyre cold)

2.9 bar (two-up and/or with luggage, tyre cold)

If tyre pressure is too low:

- Correct tyre pressure.

## Headlight

### Adjusting headlight for driving on left/driving on right

This motorcycle has a symmetric-beam low-beam headlight. If the motorcycle is ridden in a country where the opposite rule of the road applies, its symmetric low-beam headlight means that no measures are necessary to prevent the headlight beam from dazzling oncoming traffic.

### Headlight beam throw and spring preload

Headlight beam throw is generally kept constant when spring preload is adjusted to suit load. Spring preload adjustment might not suffice only if the motorcycle is very heavily loaded. Under these circumstances, headlight beam throw has to be adjusted

to suit the weight carried by the motorcycle.

#### NOTICE

If there are doubts about the correct headlight beam throw, have the setting checked by a specialist workshop, preferably an authorised BMW Motorrad dealer. ◀

### Adjusting headlight beam throw



- Slacken screws **1** on left and right.

- Adjust beam throw by tilting the headlight slightly about its horizontal axis.
- Tighten screws **1** on left and right.

### Beam-throw basic setting

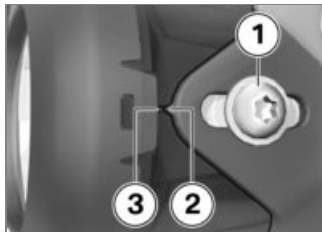

- Slacken screws **1** on left and right.
- Tilt the headlight slightly about its horizontal axis until arrowhead **2** is pointing toward marker **3**.
- Tighten screws **1** on left and right.

## Seat

### Removing seat

- Make sure the ground is level and firm and place the motorcycle on its stand.



- Turn the key to the left in seat lock **1** and hold it in this position while pressing down the front part of the seat.

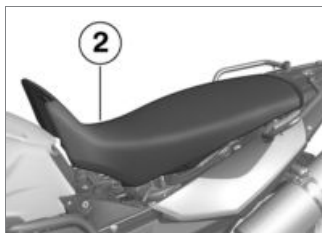

- Lift seat **2** at the front and release the key.
- Remove the seat and place it, rubber buffers down, on a clean surface.

### Installing seat



- Engage the seat in holders **3**.
- Firmly press down on the seat at the front.
  - » The seat engages with an audible click.

## Helmet holder

### Securing helmet to motorcycle

- Removing seat (👉 58).



- Use a plastic-sheathed steel cable to secure the helmet to helmet holder **1** on left or right.



 **ATTENTION**

**Attachment of the helmet on the left side of the vehicle.**

Damage due to hot rear silencer.

- Attach the helmet on the right-hand side of the vehicle.◀

 **ATTENTION**

**Incorrect positioning of the helmet lock.**

Scratch marks on trim panel.

- Make sure the lock is out of the way when you hook the helmet into position.◀

- Pass the steel cable through the helmet and the holder and position cable and helmet as shown here.
- Installing seat (➡ 58).

**Rider's Manual**  
**Stowing the Rider's Manual**

- Tuck the Rider's Manual(s) into the pocket provided.



- Make the opening side of the pocket as narrow as possible, then fasten the velcro **1**.

- Stowing the pocket in the rear of the vehicle.

– with alarm system (DWA)<sup>OE</sup>

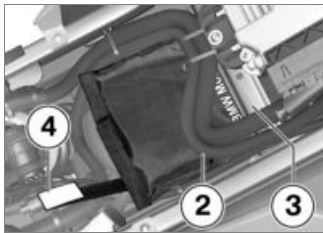

- Slightly raise the leads **2**.
- Push the pocket backwards underneath the cables and rear frame strut **3** until the rolled-up edge of the pocket is below the rear frame strut.
- Remove protective film **4** and attach the velcro to the pocket in such a way that it cannot slide around any further.<

## **Anti-theft alarm DWA**

Overview .....	62
Activation .....	62
Alarm function .....	64
Deactivation .....	65
Programming .....	66
Registration of the remote control .....	68
Synchronising.....	69
Battery.....	70

## Overview

– with alarm system (DWA)<sup>OE</sup>

### General information about the anti-theft alarm (DWA)

Any attempt to move the vehicle, change its position, start it without an authorised key or disconnect the starter battery will trigger the alarm. The sensitivity of the system is parameterised so that slight vibrations will not trigger the alarm. Once the system has been activated, any attempt to tamper with the vehicle is indicated acoustically by the siren and visually by all four turn indicators flashing in unison.

You can change some of your DWA alarm system's parameters to suit your personal preferences.

### Conserving power in the vehicle's starter battery

In order to conserve the power of the starter battery and ensure that the vehicle will start, the DWA anti-theft alarm automatically switches off the alarm function a few days after being activated. In most cases, however, the system will remain active for at least 10 days.

### Radio interference

Radio systems or devices transmitting on the same frequency as the remote control of the DWA anti-theft alarm can interfere with operation of the system. If problems of this nature occur, point the remote control toward the vehicle from another direction.

## Controls

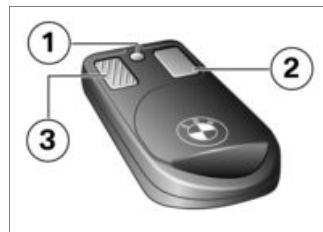

- 1 LED
- 2 Right button (▣ 64)
- 3 Left button (ribbed) (▣ 63)

## Activation

– with alarm system (DWA)<sup>OE</sup>

## Activation with motion sensor



The alarm function is activated

- by pressing button **1** on the remote control once, or
- by switching off the ignition (if programmed); when the ignition is switched off 30 seconds elapse before the start of the activation phase.

Activation is confirmed

- by the turn indicators flashing twice and
- by the alarm tone sounding twice.

If you want to activate the alarm function more than one minute after switching off the ignition, you must press button **1** for longer than one second.

### Activation phase

The anti-theft alarm needs 15 seconds to achieve fully active status. No alarm is triggered during this time.

## Conserving battery power in the control unit (anti-theft alarm activated)



If you want to activate the alarm function more than one minute after switching off the ignition, you must press button **1** for longer than one second. If it remains deactivated for approximately one hour, the anti-theft alarm shuts down in order not to draw power unnecessarily from the battery. If you want to activate the alarm function after the anti-theft alarm has shut down in

this way, you have to switch the ignition on and then off again.

### Motion sensor when motorcycle is to be transported

If you want to transport your motorcycle by train or on a trailer, for example, it is advisable to switch off the motion sensor. If the motion sensor is not switched off the severe movements occurring in transit could trigger the alarm.

### Deactivating motion sensor



- Press button **1** on the remote control a second time during the activation phase.
  - » Turn indicators flash three times.
  - » Alarm tone sounds three times.
  - » Motion sensor is deactivated.

### Alarm function

- with alarm system (DWA)<sup>OE</sup>

### Alarm triggers

An alarm can be triggered by:

- the motion sensor
- attempt to switch on the ignition with an unauthorised key
- disconnection of the anti-theft alarm (DWA) from the vehicle's battery (DWA internal battery in the anti-theft alarm provides power).

### Alarm



An alarm lasts for 26 seconds. The system is active again another 12 seconds later. You can interrupt an alarm at any time by pressing button **1** on the remote

control. This function does not change the status of the anti-theft alarm.

While an alarm is in progress an alarm tone sounds and the turn indicators flash. You can program the type of alarm tone.

### Reason for an alarm

Once you have deactivated the alarm function, the anti-theft alarm LED is active for a period of one minute to show you reasons for alarms, if any, that were triggered in your absence:

- Flashes 1x: Motion sensor; motorcycle was rocked forward/back
- Flashes 2x: Motion sensor; motorcycle was rocked to the side
- Flashes 3x: Ignition switched on with unauthorised key
- Flashes 4x: Disconnection of the anti-theft alarm from the vehicle's battery

### Information on alarm triggering

If an alarm was triggered after the last activation of the alarm function, the rider is notified accordingly by an alarm tone sounding once when the ignition is switched on.

### Deactivation

– with alarm system (DWA)<sup>OE</sup>

### Deactivating alarm function



- Press button **1** on the remote control once **or** switch on the ignition with an authorised key.



#### NOTICE

Note that you can deactivate the alarm function with the ignition key only when the kill switch is in the RUN position. ◀



#### NOTICE

If the alarm function is deactivated by the remote control and

the ignition is not subsequently switched on, the alarm function automatically goes active again after 30 seconds if "Activation after ignition OFF" is programmed. ◀

- » Turn indicators flash once.
- » Alarm tone sounds once (if programmed).
- » Alarm function is deactivated.

### Conserving battery power (anti-theft alarm deactivated)

Approximately one hour after the alarm is armed, the receiver for the remote control in the anti-theft alarm shuts down in order not to draw power unnecessarily from the battery. If you want to deactivate the alarm function after the receiver has shut down in this way, you have to switch the ignition on.

## Programming

- with alarm system (DWA)<sup>OE</sup>

### Programming options

You can customise the following parameters of your anti-theft alarm:

- Confirmation alarm tone after activation/deactivation of the anti-theft alarm in addition to visual confirmation by turn indicators flashing
- Rising and falling or intermittent alarm tone
- Automatic activation of the alarm function after the ignition is switched off

### Default settings

The anti-theft alarm ships with the following default settings:

- Confirmation alarm tone after activation/deactivation of the anti-theft alarm: No
- Alarm tone: Intermittent

- Automatic activation of the alarm function after the ignition is switched off: No

### Programming anti-theft alarm



- Deactivate the alarm function.
- Switch on the ignition.
- Press button **1** three times.
  - » Acknowledgement tone sounds once.
- Within ten seconds, switch off the ignition.
- Press button **2** three times.
  - » Acknowledgement tone sounds once.

- Within ten seconds, switch on the ignition.
- » Acknowledgement tone sounds three times.
- » The programming function is active.

Programming is a four-step process, although no function is allocated to step 2. The number of times the anti-theft alarm LED on the vehicle flashes corresponds to the active programming step. An alarm tone sounds by way of confirmation when button **1** is pressed, and an acknowledgement tone sounds when button **2** is pressed.

- **Step 1:** Do you want a confirmation tone to sound after activation/deactivation of the anti-theft alarm?

Yes:

- Press button **1**.

No:

- Press button **2**.

- **Step 2:**

No function allocated to this step.

- Press button **1** or button **2**.

- **Step 3:** Which alarm tone would you like the alarm to sound?

Rising and falling:

- Press button **1**.

intermittent:

- Press button **2**.

- **Step 4:** Do you want to have the alarm function activated automatically when you switch off the ignition?

Yes:

- Press button **1**.

No:

- Press button **2**.

## Under what circumstances is programming aborted?

There are two ways in which programming can be cancelled:

- if the ignition is switched off before completion of the last step in the programming sequence.
- automatically if more than 30 seconds are allowed to elapse between any two consecutive steps in the programming routine.

The new settings are not saved if programming is aborted.

## Saving programming

There are two ways in which programming can be saved:

- if the ignition is switched off after completion of the last step in the programming sequence

– automatically 30 seconds after completion of the last step in the programming routine

The anti-theft alarm LED goes out and four acknowledgement tones sound.

## Registration of the remote control

– with alarm system (DWA)<sup>OE</sup>

### When is it necessary to register a remote control?

If you want to register an additional remote control or register a remote control as a replacement for one that has been mislaid, you must always register all the remote control units with the anti-theft alarm. You can register a maximum of four remote control units.

## Registering remote control



- Deactivate the alarm function.
- Switch on the ignition.
- Press button **2** three times.
  - » Acknowledgement tone sounds once.
- Within ten seconds, switch off the ignition.
- Press button **2** three times.
  - » Acknowledgement tone sounds once.
- Within ten seconds, switch on the ignition.

» Acknowledgement tone sounds twice.

You can now register a maximum of four remote control units with the anti-theft alarm. Registration is a three-step process and has to be repeated for each remote control unit.

- Press and hold down button **1** and button **2**.
  - » LED flashes for ten seconds.
- As soon as the LED goes out, release button **1** and button **2**.
  - » LED lights up.
- Press button **1** or button **2**.
  - » Alarm tone sounds once.
  - » LED goes out.
  - » Remote control has been registered.
- Repeat this three-step procedure for each additional remote control.

## Termination of registration

Registration is terminated in the following situations:

- 4 remote control units have been logged on.
- Ignition is switched OFF.
- 30 seconds elapse without a button being pressed after the ignition has been switched off.
- 30 seconds elapse without a button being pressed after a remote control unit has been registered.

When registration terminates the LED flashes and the acknowledgement tone sounds three times.

## Synchronising

- with alarm system (DWA)<sup>OE</sup>

## When is it necessary to synchronise the remote control?

The remote control has to be synchronised if the buttons of the remote control have been pressed more than 256 times outside the receiver's range. Once this limit has been reached, the receiver on the vehicle will no longer react to the signals from the remote control.

## Synchronising remote control



- Press and hold down button **1** and button **2**.
    - » LED flashes for ten seconds.
  - As soon as the LED goes out, release button **1** and button **2**.
    - » LED lights up.
  - Press button **1** or button **2**.
    - » LED goes out.
- Remote control has been synchronised.

## Battery

– with alarm system (DWA)<sup>OE</sup>

### When does the battery have to be changed?

The batteries in the remote control are due to be changed after approximately 2-3 years. You can tell that the battery is weak if the LED does not light up or lights up only briefly when a button is pressed.

### Changing battery

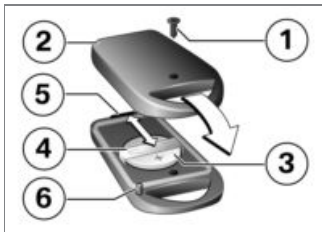

- Remove screw **1** and remove bottom part of housing **2**.

- Slide old battery **3** forward from under retainer **4**.



### ATTENTION

#### Batteries unsuitable or not inserted in compliance with correct procedure.

Component damage

- Use only the specified type of battery (see "Technical Data").
- When inserting the battery, always make sure polarity is correct. ◀
- Slip the new battery into position, making sure that the positive terminal of the battery is facing up.
- Position the bottom part of the housing at projection **5** of the front edge and close the housing, noting two guide pins **6**.
- Install the screw.
- » The LED on the remote control lights up, indicating that the

remote control has to be activated.

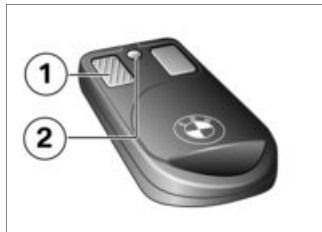

- To activate the remote control, make sure that it is within range of the receiver and press button **1** twice.
  - » LED **2** starts flashing and then goes out after a few seconds.
  - » The remote control is again ready for use.

## **Riding**

Safety instructions .....	72
Comply with checklist.....	75
Starting .....	76
Running in .....	78
Speed .....	79
Off-roading .....	80
Brakes .....	81
Parking your motorcycle .....	82
Refuelling .....	82
Securing motorcycle for transportation .....	84

## Safety instructions

### Rider's equipment

The following clothing will protect you for every journey:

- Helmet
- Motorcycling jacket and trousers
- Gloves
- Boots

This applies even to short journeys, and to every season of the year. Your authorised BMW Motorrad dealer will be glad to advise you on the correct clothing for every purpose.

### Restricted angle of heel

- with lowered suspension<sup>OE</sup>

A motorcycle with lowered suspension has less ground clearance and cannot corner at angles of heel as extreme as those achievable by a counterpart motorcycle with

standard-height suspension (see the section entitled "Technical data").



### WARNING

**When a motorcycle with lowered suspension is cornering, certain components can come into contact with the surface at a bank angle less than that to which the rider is accustomed.**

Risk of falling

- Carefully try out the limits of the motorcycle's bank angle and adapt your style of riding accordingly.◀

Test your motorcycle's angle of heel in situations that do not involve risk. When riding over kerbs and similar obstacles, bear in mind that your motorcycle's ground clearance is limited.

Lowering the motorcycle's suspension shortens suspension travel. Ride comfort might be restricted as a result. Be sure to adjust spring preload accordingly, particularly for riding two-up.

### Load correctly



### WARNING

**Handling adversely affected by overloading and imbalanced loads.**

Risk of falling

- Do not exceed the permissible gross weight and be sure to comply with the instructions on loading.◀
- Adjusting spring preload setting and damping to the total weight.
- with cases<sup>OA</sup>
- Ensure that the case volumes on the left and right are equal.

- Make sure that the weight is uniformly distributed between right and left.
  - Pack heavy items at the bottom of the cases and toward the inboard side.
  - Note the maximum permissible payload and the speed limit for riding with cases fitted, as stated on the label inside the case (see also the section entitled "Accessories").<
- with topcase<sup>OA</sup>
- Note the maximum permissible payload and the speed limit for riding with topcase fitted, as stated on the label inside the case (see also the section entitled "Accessories").<
- with tank rucksack<sup>OA</sup>
- Note the maximum permissible payload and the speed limit for riding with the tank rucksack fitted.

 Payload of tank bag
max 5 kg

 Maximum permissible speed for riding with the tank bag fitted to the motorcycle
max 130 km/h<

– with rear softbag<sup>OA</sup>

- Note the maximum payload and the speed limit for riding with the rear softbag fitted.

 Payload of rear softbag
max 1.5 kg

 Payload of rear softbag
max 1.5 kg<

## Speed

If you ride at high speed, always bear in mind that various boundary conditions can adversely affect the handling of your motorcycle, e.g.:

- Spring-strut and shock-absorber system not set up correctly
- Imbalanced load
- Loose clothing
- Insufficient tyre pressure
- Poor tyre tread
- Added luggage systems such as cases, topcase and tank rucksack.

## Maximum speed with knobbly tyres or winter tyres



**Top speed of the motorcycle higher than the permissible**

## maximum rated speed of the tyres.

Risk of accident due to tyre damage at high speed.

- Comply with the tyre-specific speed restrictions.◀

Always bear the maximum permissible speed of the tyres in mind when riding a motorcycle fitted with knobbly tyres or winter tyres.

Affix a label stating the maximum permissible speed to the instrument panel in the rider's field of vision.

## Risk of poisoning

Exhaust fumes contain carbon monoxide, which is colourless and odourless but highly toxic.



### WARNING

## Exhaust gases adversely affecting health.

Risk of asphyxiation

- Do not inhale exhaust fumes.
- Do not run the engine in an enclosed space.◀

## Risk of burn injury



### CAUTION

## Engine and exhaust system become very hot when the vehicle is in use.

Risk of burn injury

- When you park the vehicle make sure that no-one and no objects can come into contact with the hot engine and exhaust system.◀

## Catalytic converter

If misfiring causes unburned fuel to enter the catalytic converter, there is a danger of overheating and damage.

The following guidelines must be observed:

- Do not run the fuel tank dry
- Do not attempt to start or run the engine with a spark-plug cap disconnected
- Stop the engine immediately if it misfires
- Use only unleaded fuel
- Comply with all specified maintenance intervals.



### ATTENTION

## Unburned fuel in catalytic converter.

Damage to catalytic converter.

- Note the points listed for protection of the catalytic converter.◀

## Risk of overheating



### ATTENTION

## Engine running for prolonged period with vehicle at standstill.

Overheating due to insufficient cooling. In extreme cases, the motorcycle could catch fire.

- Do not allow the engine to idle unnecessarily.
- Ride away immediately after starting the engine.◀

## Tampering



### ATTENTION

#### **Tampering with the motorcycle (e.g. engine management ECU, throttle valves, clutch).**

Damage to the affected parts, failure of safety-relevant functions. Damage due to tampering is not covered by the warranty.

- Do not tamper with the vehicle in any way that could result in tuned performance.◀

## Comply with checklist

- At regular intervals, use the checklist below to check your motorcycle.

### Always before riding off:

- Operation of the brake system
- Operation of the lights and signalling equipment
- Checking clutch function (▶▶▶ 111).
- Check the tyre tread depth (▶▶▶ 113).
- Cases correctly installed and luggage secured

### Every 3rd refuelling stop:

- without Electronic Suspension Adjustment (ESA)<sup>OE</sup>
- Adjust spring preload for rear wheel (▶▶▶ 52).
- Adjust the damping for rear wheel (▶▶▶ 54).◀

– with Electronic Suspension Adjustment (ESA)<sup>OE</sup>

- Adjust the chassis and suspension (▶▶▶ 55).◀
- Check engine oil level (▶▶▶ 105).
- Check front brake pad thickness (▶▶▶ 107).
- Check the brake pad thickness, rear brakes (▶▶▶ 108).
- Check brake-fluid level, front brakes (▶▶▶ 109).
- Check the brake-fluid level, rear brakes (▶▶▶ 110).
- Checking coolant level (▶▶▶ 111).
- Lubricate the chain (▶▶▶ 113).
- Check chain sag (▶▶▶ 113).

## Starting

### Start engine

#### ATTENTION

#### Sufficient gearbox lubrication only with the engine is running.

Gearbox damage

- Do not allow the motorcycle to roll for a lengthy period of time or push it a long distance with the engine switched off.◀
- Switch on the ignition.
  - » Pre-ride check is performed (▣▣▣ 76)
  - » ABS self-diagnosis is in progress. (▣▣▣ 77)
  - with Automatic Stability Control (ASC)<sup>OE</sup>
  - » ASC self-diagnosis is performed. (▣▣▣ 78)◀
- Select neutral or, if a gear is engaged, pull the clutch lever.

#### NOTICE

You cannot start the motorcycle with the side stand extended and a gear engaged. The engine will switch itself off if you start it with the gearbox in neutral and then engage a gear before retracting the side stand.◀

- When starting a cold engine at low ambient temperatures: disengage the clutch and turn the twistgrip slightly to open the throttle.



- Press starter button 1.

#### NOTICE

The start attempt is automatically interrupted if battery voltage is too low. Recharge the battery before you start the engine, or use jump leads and a donor battery to start.

See the subsection on jump starting in "Maintenance" for more details.◀

- » The engine starts.
- » If the engine refuses to start, consult the troubleshooting chart in the section entitled "Technical data" (▣▣▣ 142)

#### Pre-ride check

The instrument panel runs a test of the instruments and the telltale and warning lights when the ignition is switched on: this is the so-called "Pre-Ride-Check". The test is aborted if you start the engine before it completes.

## Phase 1

The rev. counter and speedometer needles both swing to the limit values on their scales. At the same time, all the warning lights and telltale lights are switched on in succession.

## Phase 2

The general warning light changes from yellow to red.

## Phase 3

The rev. counter and speedometer needles both swing to the starting position on their scales. At the same time, all the warning lights and telltale lights are switched off in reverse sequence.

If a needle did not move or if a warning light or telltale light did not show:

- Have the fault rectified as quickly as possible by a

specialist workshop, preferably an authorised BMW Motorrad dealer.

## ABS self-diagnosis

BMW Motorrad ABS performs self-diagnosis to ensure its operability. Self-diagnosis is performed automatically when you switch on the ignition. The motorcycle has to move forward a few metres for the wheel-speed sensors to be tested.

### Phase 1

Test of the diagnosable system components with the vehicle at a standstill.



ABS telltale and warning light flashes.

### Phase 2

Test of the wheel-speed sensors as the vehicle pulls away from rest.



ABS telltale and warning light flashes.

## ABS self-diagnosis completed

The ABS telltale and warning light goes out.

- Check all the telltale and warning lights.  
After the ABS self-diagnosis completes, an indicator showing an ABS fault will appear.
- You can continue to ride. Bear in mind that the ABS function is not available.
- Have the fault rectified as quickly as possible by a specialist workshop, preferably an authorised BMW Motorrad dealer.

## ASC self-diagnosis

– with Automatic Stability Control (ASC)<sup>OE</sup>

BMW Motorrad ASC performs self-diagnosis to ensure its operability. Self-diagnosis is performed automatically when you switch on the ignition.

### Phase 1

» Test of the diagnosis-compatible system components with the vehicle at a standstill.



ASC telltale and warning light slow-flashes.

### Phase 2

» Test of the diagnosis-compatible system components while the motorcycle is on the move (speed at least 5 km/h).



ASC telltale and warning light slow-flashes.

## ASC self-diagnosis completed

» The ASC telltale and warning light goes out.

If an indicator showing an ASC fault appears when ASC self-diagnosis completes:

- You can continue to ride. Bear in mind that the ASC function is not available.
- Have the fault rectified as quickly as possible by a specialist workshop, preferably an authorised BMW Motorrad dealer.

## Running in

### Engine

- Until the first running-in check, vary the throttle opening and engine-speed range frequently; avoid riding at constant engine rpm for prolonged periods.
- Try to do most of your riding during this initial period on

twisting, fairly hilly roads, avoiding high-speed main roads and highways if possible.

- Comply with the rpm limits for running in.

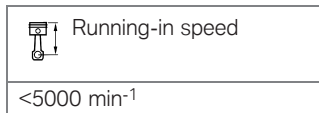

- Do not omit the first running-in check after 500 - 1200 km.

## Brake pads

New brake pads have to bed down before they can achieve their optimum friction levels. You can compensate for this initial reduction in braking efficiency by exerting greater pressure on the levers.



### New brake pads.

Longer stopping distance. Risk of accident.

- Apply the brakes in good time.◀

## Tyres

New tyres have a smooth surface. This must be roughened by riding in a restrained manner at various heel angles until the tyres are run in. This running in procedure is essential if the tyres are to achieve maximum grip.

### WARNING

#### **New tyres losing grip on wet roads and at extreme bank angles.**

Risk of accident

- Ride carefully and avoid extremely sharp inclines.◀

## Speed

– with on-board computer<sup>OE</sup>

## Redline warning



The redline warning indicates that engine revolutions have reached the rev. counter's red segment. The anti-theft alarm telltale light **1** flashes red to indicate that the engine is redlining.

The signal remains active until you shift up or reduce engine speed. You can activate or deactivate the redline warning.

## Activating redline warning

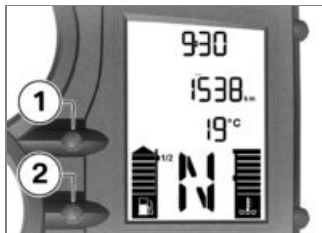

- Press button **1** and button **2** at the same time and hold them down until the reading changes.
  - » FLASH (redline warning) appears, along with ON or OFF.
- Repeatedly press button **1** until the reading shows the mode you want.
  - » ON: Redline warning activated.
  - » OFF: Redline warning deactivated.
- To save the setting, press button **1** and button **2** at the same time and hold

them down until the reading changes.

## Off-roading

### After off-roading

BMW Motorrad recommends checking the following after riding the motorcycle off-road:

### Tyre pressure



#### WARNING

### Riding on surfaced roads with tyre pressures lowered for off-roading.

Risk of accident due to impaired handling characteristics.

- Always check that the tyre pressures are correct. ◀

### Brakes



#### WARNING

### Riding on unsurfaced roads or dirty road surfaces.

Delayed braking effect due to dirty brake discs and brake pads.

- Apply the brakes in good time until the brakes have been cleaned. ◀



#### ATTENTION

### Riding on unsurfaced roads or dirty road surfaces.

Increased brake-pad wear.

- Check the thickness of the brake pads more frequently and replace the brake pads in good time. ◀

### Spring preload and shock-absorber settings



#### WARNING

### Changed values for spring preload and spring-strut damping for riding off-road.

Impaired handling characteristics on surfaced roads.

- If you have been off-roading, be sure to correct spring preload and spring-strut damping characteristics before you return to surfaced roads. ◀

### Rims

BMW Motorrad recommends checking the rims for damage after off-roading.

### Air filter element



#### ATTENTION

### Dirty air-filter element.

Engine damage

- If you ride in dusty terrain check the air filter element for clogging at shorter intervals; clean or replace as necessary. ◀

Operation in very dusty conditions (desert, steppes, or the like) necessitates the use of air filter elements specially designed for conditions of this nature.

## Brakes

### How can stopping distance be minimised?

Each time the brakes are applied, a load distribution shift takes place with the load shifting forward from the rear to the front wheel. The sharper the vehicle decelerates, the more load is shifted to the front wheel. The higher the wheel load, the more braking force can be transmitted without the wheel locking.

To optimise stopping distance, apply the front brakes rapidly and keep on increasing the force you apply to the brake lever. This makes the best possible use of the dynamic increase in load at the front wheel. Remember to pull the clutch at the same time. In the "panic braking situations" that are trained so frequently, braking force is applied as rapidly as possible and with the

rider's full force applied to the brake levers; under these circumstances, the dynamic shift in load distribution cannot keep pace with the increase in deceleration and the tyres cannot transmit the full braking force to the surface of the road. Under these circumstances the front wheel can lock up.

BMW Motorrad ABS prevents the front wheel from locking up.

### Descending mountain passes



#### Braking only with the rear brake on mountain descents.

Brake fade. Destruction of the brakes due to overheating.

- Use both front and rear brakes, and make use of the engine's braking effect as well. ◀

### Wet and dirty brakes

Wetness and dirt on the brake discs and the brake pads diminish braking efficiency.

Delayed braking action or poor braking efficiency must be reckoned with in the following situations:

- Riding in the rain or through puddles of water
- After the vehicle has been washed
- Riding on salted or gritted roads
- After work has been carried on the brakes, due to traces of oil or grease
- Riding on dirt-covered surfaces or off-road.



#### Moisture and dirt.

Diminished braking effect.

- Apply the brakes lightly while riding to remove wetness and

dirt, or dismount and clean the brakes.

- Think ahead and brake in good time until full braking efficiency is restored.◀

## Parking your motorcycle

### Side stand

- Switch off the engine.



#### ATTENTION

### Poor ground underneath the stand.

Risk of damage to parts if vehicle topples.

- Always check that the ground under the stand is level and firm.◀



#### ATTENTION

### Additional weight placing strain on the side stand.

Risk of damage to parts if vehicle topples.

- Do not sit or lean on the vehicle while it is propped on the side stand.◀
- Extend the side stand and prop the motorcycle on the stand.
- If the camber of the roadway permits, turn the handlebars all the way to the left.
- On a gradient, the motorcycle should always face uphill; select 1st gear.

### Centre stand

– with centre stand<sup>OE</sup>

- Switch off the engine.



#### ATTENTION

### Poor ground underneath the stand.

Risk of damage to parts if vehicle topples.

- Always check that the ground under the stand is level and firm.◀



#### ATTENTION

### Centre stand retracts due to severe movements.

Risk of damage to parts if vehicle topples.

- Do not lean or sit on the vehicle with the centre stand extended.◀
- Extend the centre stand and lift the motorcycle onto the stand.
- On a gradient, the motorcycle should always face uphill; select 1st gear.

## Refuelling

### Fuel grade

For optimum fuel consumption, fuel should be sulphur-free or with the lowest sulphur content possible.



## ATTENTION

### Leaded fuel.

Damage to catalytic converter.

- Do not attempt to run the vehicle on leaded fuel or fuel with metallic additives, e.g. manganese or iron. ◀
- You can run the engine on fuel with a maximum ethanol content of 10 %, i.e. E10.



Recommended fuel grade

Super unleaded (max. 10 % ethanol, E10)  
95 ROZ/RON  
89 AKI

– with regular unleaded<sup>OE</sup>



Recommended fuel grade

Regular unleaded (slight power- and consumption-related restrictions) (max. 10 % ethanol, E10)  
91 ROZ/RON  
87 AKI◀

## Refuelling



### WARNING

#### Fuel is highly flammable.

Risk of fire and explosion.

- Do not smoke. Never bring a naked flame near the fuel tank. ◀



### WARNING

#### Escape of fuel due to heat-induced expansion if fuel tank is overfilled.

Risk of falling

- Do not overfill the fuel tank. ◀



## ATTENTION

### Fuel attacks plastic surfaces.

Surfaces become unsightly or dull.

- Clean plastic parts immediately after contact with fuel. ◀
- Make sure the ground is level and firm and place the motorcycle on its side stand.



## NOTICE

The volume of the tank can be utilised to the full only when the motorcycle is propped on its side stand. ◀

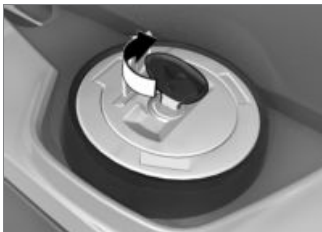

- Open the protective cap.
- Use the ignition key to unlock the fuel filler cap and pop the cap open.



- Do not fill the tank past the bottom edge of the filler neck.

**NOTICE**

When refuelling after running on reserve, make sure that you top up the tank to a level above reserve, as otherwise the new level will not be registered and the fuel warning light indicating that the level is down to reserve will not be switched off. ◀

**NOTICE**

The "usable fuel capacity" specified in the technical data is the quantity that the fuel tank could hold if it had been run dry and the engine had cut out due to a lack of fuel. ◀



Usable fuel capacity

approx. 16 l



Reserve fuel

min 2.7 l

- Press the fuel tank cap down firmly to close.
- Remove the key and close the protective cap.

## Securing motorcycle for transportation

- Make sure that all components that might come into contact with straps used to secure the motorcycle are adequately protected against scratching, e.g. adhesive tape or soft cloths should be used for this purpose.



## ATTENTION

### **Vehicle topples to side when being lifted on to stand.**

Risk of damage to parts if vehicle topples.

- Secure the vehicle to prevent it toppling, preferably with the assistance of a second person.◀
- Push the motorcycle onto the transportation flat and hold it in position: do not place it on the side stand or centre stand.

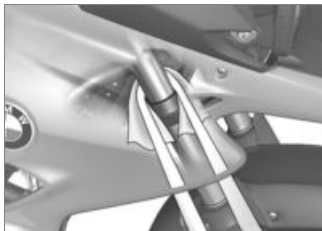

## ATTENTION

### **Trapping of components.**

Component damage

- Do not trap components such as brake lines or cable legs.◀
- At the front, secure the straps to the bottom fork bridge on both sides and tighten the straps.



- At the rear, secure the straps to the rear frame on both sides and tighten the straps.
- Tighten all the straps uniformly; the vehicle's suspension should be compressed as tightly as possible front and rear.



## Engineering details

Brake system with BMW Motorrad ABS .....	88
Electronic engine management with BMW Motorrad ASC.....	90
Tyre pressure monitoring RDC .....	91

## Brake system with BMW Motorrad ABS

### How does ABS work?

The amount of braking force that can be transferred to the road depends on factors that include the coefficient of friction of the road surface. Loose stones, ice and snow or a wet road all have much lower coefficients of friction than a clean, dry asphalt surface. The lower the coefficient of friction, the longer the braking distance.

If the rider increases braking pressure to the extent that braking force exceeds the maximum transferable limit, the wheels start to lock and the motorcycle loses its directional stability; a fall is imminent. Before this situation can occur, ABS intervenes and adapts braking pressure to the maximum transferrable braking force, so the wheels continue

to turn and directional stability is maintained irrespective of the condition of the road surface.

### What are the effects of surface irregularities?

Humps and surface irregularities can cause the wheels to lose contact temporarily with the road surface; if this happens the braking force that can be transmitted to the road can drop to zero. If the brakes are applied under these circumstances the ABS has to reduce braking force to ensure that directional stability is maintained when the wheels regain contact with the road surface. At this instant the BMW Motorrad ABS must assume an extremely low coefficient of friction, so that the wheels will continue to rotate under all imaginable circumstances, because this is the precondition for ensuring directional stability.

As soon as it registers the actual circumstances, the system reacts instantly and adjusts braking force accordingly to achieve optimum braking.

### Rear wheel lift

Under very severe and sudden deceleration, however, under certain circumstances it is possible that the BMW Motorrad ABS will be unable to prevent the rear wheel from lifting clear of the ground. If this happens the outcome can be a highside situation in which the motorcycle can flip over.



#### WARNING

#### Rear wheel lift due to severe braking.

Risk of falling

- When you brake sharply, bear in mind that ABS control cannot always be relied on to pre-

vent the rear wheel from lifting clear of the ground.◀

## What is the design baseline for BMW Motorrad ABS?

Within the limits imposed by physics, BMW Motorrad ABS ensures directional stability on any surface. The system is not optimised for special requirements that apply under extreme competitive situations off-road or on the track.

## Special situations

The speeds of the front and rear wheels are compared as one means of detecting a wheel's incipient tendency to lock. If the system registers implausible values for a lengthy period the ABS function is deactivated for safety reasons and an ABS fault message is issued. Self-dia-

gnosis has to complete before fault messages can be issued. In addition to problems with the BMW Motorrad ABS, exceptional riding conditions can lead to a fault message being issued.

### Exceptional riding conditions:

- Riding for a lengthy period with the front wheel lifted off the ground (wheelie).
- Rear wheel rotating with the vehicle held stationary by applying the front brake (burn-out).
- Heating up with the motorcycle on the centre stand or an auxiliary stand, engine idling or with a gear engaged.
- Rear wheel locked for a lengthy period, for example while descending off-road.

If a fault message should be triggered due to one of the above-described driving

conditions, the ABS function can be re-activated by switching the ignition off and then on again.

## What significance devolves on regular maintenance?

### WARNING

#### Brake system not regularly serviced.

Risk of accident

- In order to ensure that the BMW Motorrad ABS is always maintained in optimum condition, it is essential for you to comply strictly with the specified inspection intervals.◀

## Reserves for safety

The potentially shorter braking distances which BMW Motorrad ABS permits must not be used as an excuse for careless riding. ABS is primarily a means of en-

sureing a safety margin in genuine emergencies.

Take care when cornering! When you apply the brakes on a corner, the motorcycle's weight and momentum take over and even BMW Motorrad ABS is unable to counteract their effects.

## Electronic engine management with BMW Motorrad ASC

– with Automatic Stability Control (ASC)<sup>OE</sup>

### How does ASC work?

The BMW Motorrad ASC system compares the speed of rotation of the front wheel and the rear wheel. The differential is used to compute slip as a measure of the reserves of stability available at the rear wheel. If slip exceeds a certain limit the engine control in-

tervenes, adapting engine torque accordingly.

### What is the design baseline for BMW Motorrad ASC?

BMW Motorrad ASC is designed as an assistant system for the rider and for use on public roads. The extent to which the rider affects the ASC can be considerable (weight shifts when cornering, items of luggage loose on the motorcycle), especially when style of riding takes rider and machine close to the limits imposed by physics.

The system is not optimised for special requirements that apply under extreme competitive situations off-road or on the track. You have the option of deactivating the BMW Motorrad ASC system for these circumstances.



## WARNING

### Risky riding.

Risk of accident despite ASC.

- Invariably, it remains the rider's responsibility to adapt riding style to riding conditions.
- Do not take risks that would negate the additional safety offered by this system. ◀

### Special situations

In accordance with the laws of physics, the ability to accelerate is restricted more and more as the angle of heel increases. Consequently, there can be a perceptible lag in acceleration out of very tight bends.

The speeds of the front and rear wheels are compared as one means of detecting the rear wheel's incipient tendency to spin or slip sideways. If the system registers implausible values

for a lengthy period the ASC function is deactivated for safety reasons and an ASC fault message is issued. Self-diagnosis has to complete before fault messages can be issued.

The BMW Motorrad ASC can shut down automatically under the exceptional riding conditions outlined below.

#### **Exceptional riding conditions:**

- Riding for a lengthy period with the rear wheel lifted off the ground (wheelie) with ASC deactivated
- Rear wheel rotating with the vehicle held stationary by applying the front brake (burn-out)
- Heating up with the motorcycle on the centre stand or an auxiliary stand, engine idling or with a gear engaged

Accelerating the motorcycle to a speed in excess of 5 km/h after switching the ignition off and then on again reactivates the ASC.

If the front wheel lifts clear of the ground under severe acceleration, the ASC reduces engine torque until the front wheel regains contact with the ground. Under these circumstances, BMW Motorrad recommends rolling the throttle slightly closed so as to restore stability with the least possible delay.

When riding on a slippery surface, never snap the throttle twistgrip fully closed without pulling the clutch at the same time. Engine braking torque can cause the rear wheel to lock, with a corresponding loss of stability. The BMW Motorrad ASC is un-

able to control a situation of this nature.

## **Tyre pressure monitoring RDC**

- with tyre pressure monitoring (RDC)<sup>OE</sup>

### **Function**

A sensor integrated into each tyre measures the air temperature and the air pressure inside the tyre and transmits this information to the control unit.

Each sensor has a centrifugal-force tripswitch that does not enable transmission of the measured values until the vehicle has accelerated to about 30 km/h. The display shows -- for each tyre until the tyre-pressure signal is received for the first time. The sensors continue to transmit the measured-value signals for ap-

proximately 15 minutes after the vehicle comes to a stop.

## Temperature compensation

Tyre pressure is a temperature-sensitive variable: pressure increases as tyre temperature rises and decreases as tyre temperature drops. Tyre temperature depends on ambient temperature, on the style of riding and the duration of the ride.

The tyre-pressure readings shown by the multifunction display are temperature-compensated; the reference tyre temperature for these readings is always 20 °C. The gauges on forecourt air lines do not compensate for temperature. The tyre pressure recorded depends on tyre temperature. In most instances, therefore, these gauge readings will not tally with

the pressures shown by the multifunction display.

## Tyre-pressure ranges

The RDC control unit differentiates between three tyre-pressure ranges, all of which are parameterised for the motorcycle:

- Tyre pressure within permitted tolerance
- Tyre pressure close to limit of permitted tolerance
- Tyre pressure outside permitted tolerance

## Pressure adaptation

Compare the RDC readings on the multifunction display with the value in the table on the inside cover of the Rider's Manual. Then use the air line to compensate for the difference between the RDC reading and the value in the table.

Example: According to the Rider's Manual, tyre pressure should be 2.5 bar, but the reading in the multifunction display is 2.3 bar. The gauge on the air line shows 2,4 bar. You must now increase tyre pressure by the 0,2 bar difference between the value in the table and the RDC reading; when the air-line gauge shows 2,6 bar, the tyre is inflated to the correct pressure.

## **Accessories**

General instructions.....	94
Power sockets .....	94
Luggage .....	95
Cases.....	95
Topcase .....	99

## General instructions

BMW Motorrad recommends the use of parts and accessories for your motorcycle that are approved by BMW for this purpose. Your BMW Motorrad authorised dealer will offer you professional advice in your selection of original BMW parts and accessories and other products approved by BMW.

These parts and products have been tested by BMW for safety, function and suitability. BMW accepts product liability for them. BMW is unable to accept any liability whatsoever for parts and accessories which it has not approved.

Also bear in mind the information on the effect of wheel size on running-gear control systems (►► 115).



### CAUTION

#### Use of other-make products.

Safety risk

- BMW Motorrad cannot examine or test each product of outside origin to ensure that it can be used on or in connection with BMW vehicles without constituting a safety hazard. Country-specific official authorisation does not suffice as assurance. Tests conducted by these instances cannot make provision for all operating conditions experienced by BMW vehicles and, consequently, they are not sufficient in some circumstances.
- Use only parts and accessories approved by BMW for your vehicle. ◀

Whenever you are planning modifications, comply with all the legal requirements. Make

sure that the vehicle does not infringe the national road-vehicle construction and use regulations applicable in your country.

## Power sockets

Notes on use of power sockets:

### Automatic shutdown

Power sockets are shut down automatically under the following circumstances:

- If battery charge state is too low to maintain the motorcycle's start capability
- If maximum load capability as stated in the technical data is exceeded
- When the engine is being cranked on the starter.

### Operating electrical accessories

You can start using electrical accessories connected to the motorcycle's sockets only when

the ignition is switched on. The accessory remains operational if the ignition is subsequently switched off. Approximately 15 minutes after ignition is turned off, power sockets are switched off to lessen the burden on the on-board electrical system. Low-wattage electrical accessories might not be recognised by the vehicle's electronics. In such cases, power sockets are switched off very shortly after the ignition is turned off.

### Cable routing

The cables from the power sockets to the auxiliary devices must be routed in such a way that they:

- Do not impede the rider,
- Do not restrict the steering angle or obstruct handling,
- cannot be trapped.

## Luggage

### Lashing luggage

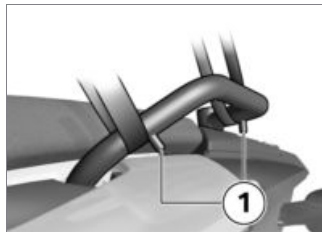

- Loop the luggage straps over the bar between the motorcycle and stops **1**.



- Position luggage strap **2** as shown here with a stuffbag as example.
- Check that the luggage is secure.

## Cases

### Opening cases

- with cases<sup>OA</sup>



- Turn key **1** in the case lock to right angles with the forward direction of travel.
- Keep the yellow latch **2** held and fold out the carry handle **3**.

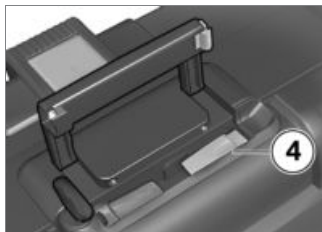

- Push yellow button **4** down and at the same time open the lid of the case.

### Close cases

– with cases<sup>OA</sup>

- Turn the lock with the key until it is at right angles to the forward direction of travel.
- Close the case lid.
- » The lid engages with an audible click.

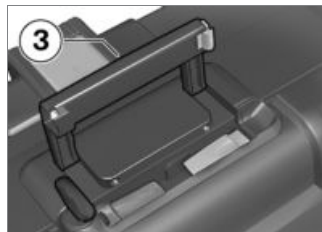

### ATTENTION

#### Closure of carrying handle with case lock latched.

Damage to locking tab.

- Make sure that the case lock is at right angles to the forward direction of travel when you close the carry handle. ◀
- Close carry handle **3**.
- Turn the key in the case lock in line with the forward direction of travel and remove the key from the lock.

## Adjusting case volume

– with cases<sup>OA</sup>

- Open the case and remove all its contents.

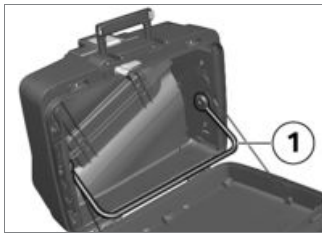

- Engage pivot lever **1** at the top limit position to set the case to minimum volume.
- Engage pivot lever **1** at the bottom limit position to set the case to maximum volume.
- Close the case.

## Removing cases

– with cases<sup>OA</sup>



- Turn key **1** in the case lock to right angles with the forward direction of travel.
- Keep the yellow latch **2** held and fold out the carry handle **3**.

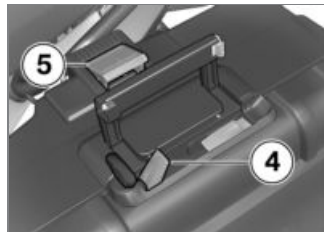

- Pull red release lever **4** up.  
» Latching flap **5** pops up.
- Fully open the latching flap.
- Take a firm grip of the handle and lift the case out of the holder.

## Installing cases

– with cases<sup>OA</sup>

- Turn the lock with the key until it is at right angles to the forward direction of travel.

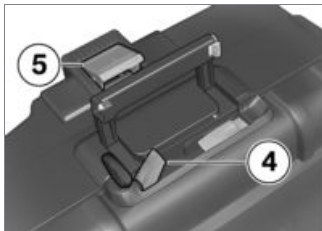

- Fully open latching flap **5**, if necessary pulling up red release lever **4**.

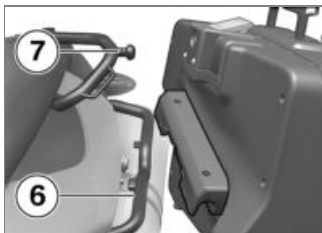

- Position the case in case carrier **6**, then pivot it until it is seated at mount **7**.

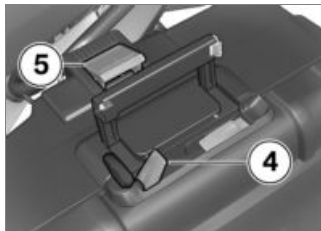

- Push latching flap **5** down as far as it will go and hold it in this position.
- Push red release lever **4** down.  
» Latching flap **5** engages.



### ATTENTION

#### Closure of carrying handle with case lock latched.

Damage to locking tab.

- Make sure that the case lock is at right angles to the forward direction of travel when you close the carry handle. ◀
- Close the carry handle.

- Turn the key parallel with the direction of travel and remove.

### Maximum payload and maximum permissible speed

Note the maximum permissible payload and the speed limit for riding with cases fitted, as stated on the label inside the case. Contact your authorised BMW Motorrad dealer if you cannot find your combination of vehicle and cases on the label. The values for the combination described here are as follows:

	Maximum permissible speed for riding with cases fitted to the motorcycle
max 180 km/h	
	Payload per case
max 10 kg	

## Topcase

### Opening topcase

– with topcase<sup>OA</sup>



- Turn key **1** in the topcase lock to the vertical position.
- Keep the yellow latch **2** held and fold out the carry handle **3**.



- Push yellow button **4** forward and at the same time push the topcase lid up.

### Closing topcase

– with topcase<sup>OA</sup>

- Turn key in the topcase lock to the vertical position.



- Press down firmly on the topcase lid to close.



### ATTENTION

#### Closure of carrying handle with case lock latched.

Damage to locking tab.

- Make sure that the topcase lock is vertical when you close the carry handle. ◀
- Close carry handle **3**.
  - » The handle engages with an audible click.
- Turn the key in the topcase lock to the horizontal position

and remove the key from the lock.

## Adjusting topcase volume

– with topcase<sup>OA</sup>

- Open the topcase and remove all its contents.



- Engage pivot lever **1** at the front limit position to set the case to maximum volume.
- Engage pivot lever **1** at the rear limit position to set the case to minimum volume.
- Close the topcase.

## Removing the topcase

– with topcase<sup>OA</sup>



- Turn key **1** in the topcase lock to the vertical position.
- Keep the yellow latch **2** held and fold out the carry handle **3**.



- Pull back red release lever **4**.  
» Latching flap **5** pops up.
- Fully open latching flap **5**.
- Take a firm grip of the handle and lift the topcase out of the holder.

## Installing topcase

– with topcase<sup>OA</sup>

- Turn key in the topcase lock to the vertical position.



- Fully open latching flap **5**, if necessary pulling red release lever **4** to the rear.

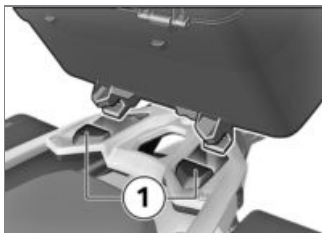

- Engage the topcase in front holders **1** of the topcase carrier plate.

- Press the topcase onto the topcase carrier plate at the rear.



- Push latching flap **5** fully closed and hold it in this position.
- Push red release lever **4** forward.  
» The latching flap engages.

#### **ATTENTION**

#### **Closure of carrying handle with case lock latched.**

Damage to locking tab.

- Make sure that the topcase lock is vertical when you close the carry handle.◀
- Close the carry handle.
- Turn the key to the horizontal position and remove.

#### **Maximum payload and maximum permissible speed**

Note the maximum permissible payload and the speed limit for riding with topcase fitted, as stated on the label inside the topcase.

Contact your authorised BMW Motorrad dealer if you cannot find your combination of vehicle and topcase on the label.

The values for the combination described here are as follows:



Maximum permissible  
speed for riding with top-  
case fitted to the vehicle

max 180 km/h



Payload of topcase

max 5 kg

## Maintenance

General instructions.....	104
Toolkit .....	104
Engine oil .....	105
Brake system .....	107
Coolant .....	111
Clutch .....	111
Rims and tyres.....	112
Chain .....	113
Wheels .....	115
Front-wheel stand .....	123
Bulbs .....	124
Body panels .....	129
Air filter .....	131
Jump-starting.....	131
Battery.....	133

## General instructions

The "Maintenance" chapter describes straightforward procedures for checking and replacing certain wear parts.

Special tightening torques are listed as applicable. The tightening torques for the threaded fasteners on your vehicle are listed in the section entitled "Technical data".

You will find information on more extensive maintenance and repair work in the Repair Manual on DVD for your vehicle, which is available from your authorised BMW Motorrad dealer.

Some of the work calls for special tools and a thorough knowledge of the technology involved. If you are in doubt consult a specialist workshop, preferably your authorised BMW Motorrad dealer.

## Toolkit

### Standard tool kit

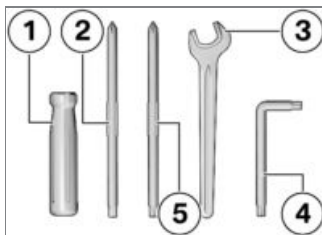

- 1** Screwdriver handle
- 2** Reversible screwdriver blade  
With star-head and plain-tip ends
  - Replacing bulbs for front and rear turn indicators (➡ 127).
  - Replacing number-plate light bulbs (➡ 128).
  - Removing battery (➡ 135).

- 3** Open-ended spanner  
Width across flats 17  
– Adjusting mirror arm (➡ 52).
- 4** Torx wrench, T40  
– Adjusting headlight beam throw (➡ 57).
- 5** Reversible screwdriver blade  
Phillips PH1 and Torx T25  
– Removing centre trim panel (➡ 129).

### Service toolkit

- with service toolkit<sup>OA</sup>

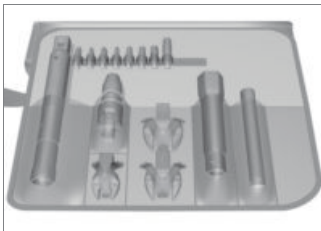

BMW Motorrad has assembled a service toolkit that is ideal for carrying out extended service work (e.g. removing and installing wheels) on this motorcycle. You can obtain the tools set from your authorised BMW Motorrad dealer.

## Engine oil

### Check engine oil level



#### ATTENTION

The oil level varies with the temperature of the oil. The higher the temperature, the

### higher the level of oil in the sump.

Misinterpretation of the oil level

- Check the oil level only after a lengthy ride or when the engine is at operating temperature.◀
- Wipe the area around the oil filler neck clean.
- Allow the engine to idle until the fan starts up, then allow it to idle one minute longer.
- Switch off the engine.
- Make sure the engine is at operating temperature and hold the motorcycle upright.
  - with centre stand<sup>OE</sup>
- Check that the engine is at operating temperature, make sure the ground is level and firm and place the motorcycle on its centre stand.<



#### ATTENTION

### Vehicle topples to side when being lifted on to stand.

Risk of damage to parts if vehicle topples.

- Secure the vehicle to prevent it toppling, preferably with the assistance of a second person.◀
- Remove oil dipstick **1**.

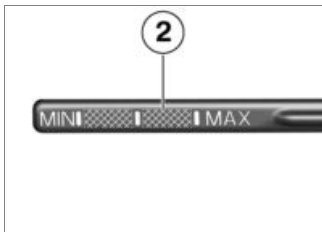

- Use a dry cloth to wipe gauge length **2** clean
- Seat the oil dipstick on the oil filler neck, but do not engage the threads.
- Remove the oil dipstick and check the oil level.

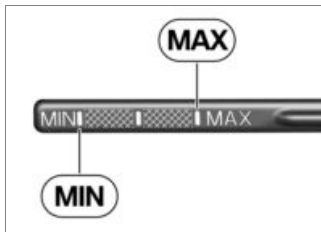

Engine oil, specified level

Between MIN and MAX marks



Engine oil, quantity for topping up

Viscosity class

max 0.4 l (Difference between MIN and MAX)

If the oil level is below the MIN mark:

- Topping up engine oil (➔ 106).

If the oil level is above the MAX mark:

- Have the oil level corrected by a specialist workshop, preferably an authorised BMW Motorrad dealer.
- Install the oil dipstick.

### Topping up engine oil

- Make sure the ground is level and firm and place the motorcycle on its stand.
- Wipe the area around the filler neck clean.



- Remove oil dipstick **1**.

## ATTENTION

### **Not enough or too much engine oil.**

Engine damage

- Always make sure that the oil level is correct.◀
- Top up the engine oil to the specified level.
- Check engine oil level (▮▮▮▶ 105).
- Install the oil dipstick.

## **Brake system**

### **Check operation of brakes**

- Pull the front brake lever.
  - » The pressure point must be clearly perceptible.
- Press the footbrake lever.
  - » The pressure point must be clearly perceptible.

If pressure points are not clearly perceptible:

## ATTENTION

### **Work on brake system not in compliance with correct procedure.**

Risk to operational reliability of the brake system.

- Have all work on the brake system undertaken by trained and qualified specialists.◀
- Have the brakes checked by a specialist workshop, preferably an authorised BMW Motorrad dealer.

### **Check front brake pad thickness**

- Make sure the ground is level and firm and place the motorcycle on its stand.

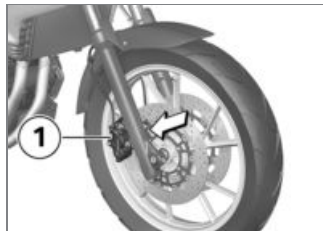

- Visually inspect the left and right brake pads to ascertain their thickness. Viewing direction: between wheel and front suspension toward brake calipers **1**.

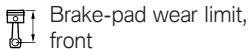
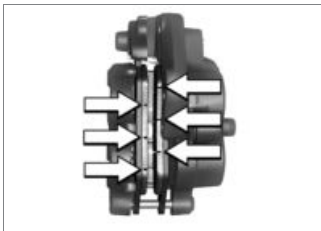

min 1.0 mm (Friction pad only, without backing plate. The wear indicators, i.e. the grooves, must be clearly visible.)

If the wear indicating marks are no longer clearly visible:



## WARNING

**Brake-pad thickness less than permissible minimum.**

Diminished braking effect. Damage to the brakes.

- In order to ensure the dependability of the brake system, do not permit the brake pads to wear past the minimum permissible thickness.◀
- Have the brake pads replaced by a specialist workshop, preferably an authorised BMW Motorrad dealer.

## Check the brake pad thickness, rear brakes

- Make sure the ground is level and firm and place the motorcycle on its stand.



- Visually inspect the brake pads to ascertain their thickness. Viewing direction: from the rear toward brake caliper **1**.

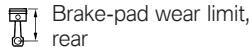

min 1.0 mm (Friction pad only, without backing plate.)

If the brake pads are worn:



## WARNING

**Brake-pad thickness less than permissible minimum.**

Diminished braking effect. Damage to the brakes.

- In order to ensure the dependability of the brake system, do not permit the brake pads to wear past the minimum permissible thickness.◀
- Have the brake pads replaced by a specialist workshop, preferably an authorised BMW Motorrad dealer.



**! WARNING**

**Not enough brake fluid in brake fluid reservoir.**

Considerably reduced braking power due to air in the brake system.

- Check the brake-fluid level at regular intervals.◀
- Check the brake fluid level in front reservoir **1**.

**NOTICE**

Wear of the brake pads causes the brake fluid level in the reservoir to sink.◀



 Brake fluid level, front (visual inspection)

Brake fluid, DOT4

It is impermissible for the brake fluid level to drop below the MIN mark.

**Check brake-fluid level, front brakes**

- Make sure the ground is level and firm and hold the motorcycle upright.
  - with centre stand<sup>OE</sup>
- Make sure the ground is level and firm and place the motorcycle on its centre stand.◀
- Move the handlebars to the straight-ahead position.

If the brake fluid level drops below the permitted level:

- Have the defect rectified as quickly as possible by a specialist workshop, preferably an authorised BMW Motorrad dealer.

### Check the brake-fluid level, rear brakes

- Make sure the ground is level and firm and hold the motorcycle upright.
- with centre stand<sup>OE</sup>
- Make sure the ground is level and firm and place the motorcycle on its centre stand.◀

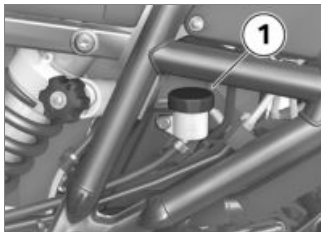

### WARNING

#### Not enough brake fluid in brake fluid reservoir.

Considerably reduced braking power due to air in the brake system.

- Check the brake-fluid level at regular intervals.◀
- Check the brake fluid level in rear reservoir **1**.

### NOTICE

Wear of the brake pads causes the brake fluid level in the reservoir to sink.◀



 Brake fluid level, rear (visual inspection)

Brake fluid, DOT4

It is impermissible for the brake fluid level to drop below the MIN mark.

If the brake fluid level drops below the permitted level:

- Have the defect rectified as quickly as possible by a specialist workshop, preferably an authorised BMW Motorrad dealer.

## Coolant

### Checking coolant level

- Make sure the ground is level and firm and place the motorcycle on its stand.



- Check the coolant level in expansion tank **1**. Viewing

direction: From in front, between windscreen and right side panel.



 Coolant, specified level
Antifreeze and corrosion inhibitor
between MIN and MAX marks on the expansion tank

If the coolant drops below the permitted level:

- Top up the coolant.

## Topping up coolant



- Open cap **1** of the expansion tank.
- Using a suitable funnel, top up with coolant until the level is correct.
- Close the cap of the expansion tank.

## Clutch

### Checking clutch function

- Pull the clutch lever.
  - » The pressure point must be clearly perceptible.

If the pressure point is not clearly perceptible:

- Have the clutch checked by a specialist workshop, preferably an authorised BMW Motorrad dealer.

## Check the clutch play

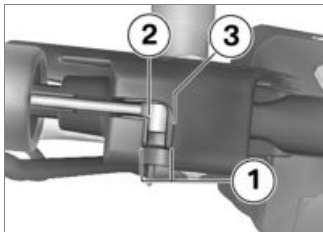

- Operate the clutch lever until resistance can be felt whilst observing the notch **1** in the manual valve.
  - » The edge **2** of the brake cable should be able to move up to the edge **3** of the manual valve.



Clutch cable play

5 mm (Handlebars in straight-ahead position)

Clutch play is out of tolerance:

- Adjusting clutch play (►► 112).

## Adjusting clutch play

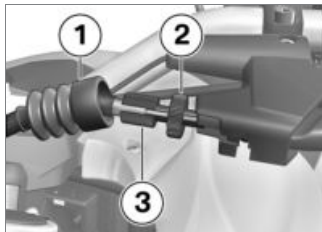

- Move the rubber grommet **1** to one side.
- Slacken nut **2**.
- To increase clutch play: Screw the adjusting screw **3** into the manual valve.

- To reduce clutch play: Un-screw the adjusting screw **3** from the manual valve.
- Check the clutch play (►► 112).
- Tighten nut **2** while holding the adjusting screw **3** in position.
- Fasten the rubber grommet **1** over the nuts.

## Rims and tyres

### Checking rims

- Make sure the ground is level and firm and place the motorcycle on its stand.
- Visually inspect the rims for defects.
- Have any damaged rims inspected by a specialist workshop and replaced if necessary, preferably by an authorised BMW Motorrad dealer.

## Check the tyre tread depth

### WARNING

#### Riding with badly worn tyres

Risk of accident due to impaired handling

- If applicable, have the tyres changed in good time before they wear to the minimum tread depth permitted by law.◀
- Make sure the ground is level and firm and place the motorcycle on its stand.
- Measure the tyre tread depth in the main tread grooves with wear marks.

### NOTICE

Wear indicators are built into the main profile grooves on each tyre. The tyre is worn out when the tyre tread has worn down to the level of the marks. The locations of the marks are indic-

ated on the edge of the tyre, e.g. by the letters TI, TWI or by an arrow.◀

If the tyre tread is worn to minimum:

- Replace tyre or tyres, as applicable.

## Chain

### Lubricating chain

#### ATTENTION

#### Inadequate cleaning and lubrication of the drive chain.

Accelerated wear.

- Clean and lubricate the drive chain at regular intervals.◀
- Lubricate the drive chain every 1000 km at the latest. Lubricate the chain more frequently if the motorcycle is ridden in wet, dusty or dirty conditions.

- Switch the ignition off and select neutral.
- Clean the drive chain with a suitable cleaning product, dry it and apply chain lubricant.
- Wipe off excess lubricant.

### Check chain sag

- Make sure the ground is level and firm and place the motorcycle on its stand.
- Turn the rear wheel until it reaches the position with the lowest amount of chain sag.

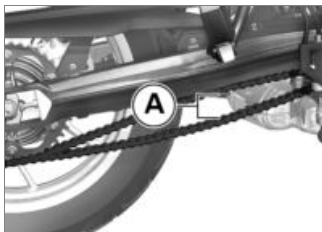

- Use a screwdriver to push the chain up and down and measure difference **A**.



Chain deflection

30...40 mm (Motorcycle with no weight applied, supported on its side stand)

– with lowered suspension<sup>OE</sup>

20...30 mm (Motorcycle with no weight applied, supported on its side stand)◀

If measured value is outside permitted tolerance:

- Adjust chain sag (▶▶ 114).

### Adjust chain sag

- Make sure the ground is level and firm and place the motorcycle on its stand.

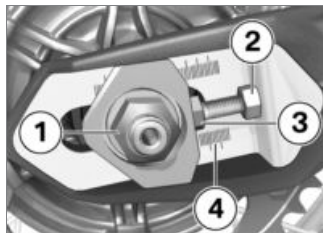

- Slacken quick-release axle nut **1**.
- Slacken locknuts **2** on left and right.
- Use adjusting screws **3** on left and right to adjust chain sag.
- Check chain sag (▶▶ 113).

- Make sure that scale readings **4** are the same on left and right.
- Tighten locknuts **2** on left and right to the specified tightening torque.



Locknut of the final-drive chain tensioning screw

19 Nm

- Tighten quick-release axle nut **1** to the specified tightening torque.



Rear quick-release axle in swinging arm

100 Nm

### Checking the chain wear

- Make sure the ground is level and firm and place the motorcycle on its stand.
- Engage 1st gear.

- Turn the rear wheel in the normal direction of travel until the chain is tensioned.
- Measure the length of the chain over 9 rivets below the rear wheel swinging arm.

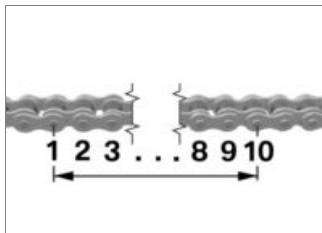

Permissible chain length

max 144.30 mm (measured **centre to centre** over 10 pins, chain pulled taut)

If the chain has stretched to the maximum permissible length:

- Seek the advice of a specialist workshop, preferably an authorised BMW Motorrad dealer.

## Wheels

### Tyre recommendation

For each size of tyre, BMW Motorrad tests and classifies as roadworthy certain makes. BMW Motorrad cannot assess the suitability or provide any guarantee of road safety for other tyres.

BMW Motorrad recommends using only tyres tested by BMW Motorrad.

It is absolutely essential to observe the maximum permissible speed and load-capacity ratings (see "Technical data").

Comply with the instructions regarding maximum speed for rid-

ing with knobby tyres or winter tyres fitted (73).

You can obtain detailed information from your authorised BMW Motorrad dealer or on the Internet at [www.bmw-motorrad.com](http://www.bmw-motorrad.com).

### Effect of wheel size on chassis and suspension control systems

Wheel size is very important as a parameter for the running-gear control systems ABS and ASC. In particular, the diameter and the width of a vehicle's wheels are programmed into the control unit and are fundamental to all calculations. Any change in these influencing variables, caused for example by a switch to wheels other than those installed ex-works, can have serious effects on the performance of the control systems.

The sensor rings are essential for correct road-speed calculation, and they too must match the motorcycle's control systems and consequently cannot be changed.

If you decide that you would like to fit non-standard wheels to your motorcycle, it is very important to consult a specialist workshop beforehand, preferably an authorised BMW Motorrad dealer. In some cases, the data programmed into the control units can be changed to suit the new wheel sizes.

### RDC adhesive label

- with tyre pressure monitoring (RDC)<sup>OE</sup>

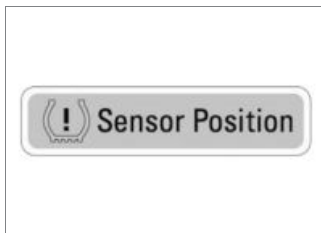

### ATTENTION

#### Tyre removal not in compliance with correct procedure.

Damage to RDC sensors.

- Be sure to explain to the specialist workshop or authorised BMW Motorrad dealer that the wheel is fitted with an RDC sensor. ◀

If the motorcycle is equipped with RDC, each wheel rim bears an adhesive label indicating the position of the RDC sensor.

### Removing front wheel

- Make sure the ground is level and firm and place the motorcycle on its stand.



- Remove screw **1** and remove the ABS sensor from its bore.



- Remove screws **2** from the right brake caliper.

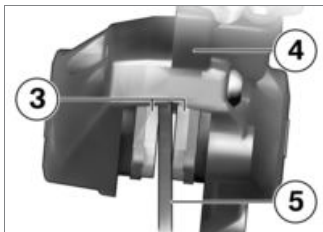

- Force the brake pads **3** slightly apart by rocking brake caliper **4** back and forth against brake disc **5**.

- Mask off the parts of the wheel rim that could be scratched in the process of removing the brake caliper.

### **ATTENTION**

#### **Brake pads pushed together with brake caliper removed.**

It is not possible to slip the brake caliper over the brake disc.

- Do not operate the brake lever while a brake caliper has been removed.◀
- Carefully pull the brake caliper back and out until clear of the brake disc.
- Place the motorcycle on a suitable auxiliary stand.
  - with centre stand<sup>OE</sup>
- Make sure the ground is level and firm and place the motorcycle on its centre stand.<

- Make sure the ground is level and firm and place the motorcycle on its stand.
- Raise front of motorcycle until the front wheel can turn freely. BMW Motorrad recommends the BMW Motorrad front-wheel stand for lifting the motorcycle.
- Install the front-wheel stand (▶ 123).



- Remove right-hand axle clamping screw **1**.
- Remove axle **2**, while supporting the wheel.

- Do not remove the grease from the axle.
- Roll the front wheel forward to remove.

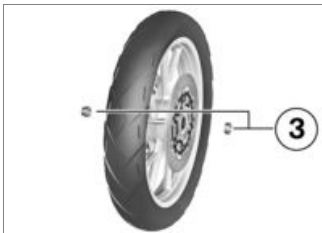

- Remove the spacing bushing **3** from the wheel hub on the left and right hand sides.

## Installing front wheel

### WARNING

#### Use of a non-standard wheel.

Malfunctions in operation of ABS and ASC.

- See the information on the effect of wheel size on the ABS

and ASC systems at the start of this chapter. ◀

### ATTENTION

#### Tightening threaded fasteners to incorrect tightening torque.

Damage, or threaded fasteners work loose.

- Always have the security of the fasteners checked by a specialist workshop, preferably an authorised BMW Motorrad dealer. ◀

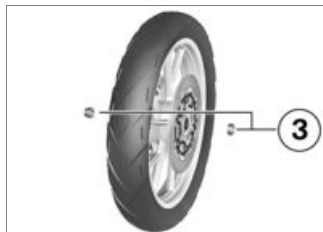

- Slip spacing bushing **3** onto the left and right-hand sides of the wheel hub.

### ATTENTION

#### Front wheel installed wrong way round.

Risk of accident

- Note direction-of-rotation arrows on tyre or rim. ◀
- Roll the front wheel into position between the forks, making sure that the brake disc passes between the brake pads of the brake caliper on the left.



- Raise the front wheel, insert axle **2** and tighten to specified torque.

 Quick-release axle, front, in axle holder
30 Nm

- Remove the front-wheel stand.
  - without centre stand<sup>OE</sup>
- Remove the auxiliary stand.<
- Ease the right brake caliper onto the brake disc.



- Tighten screws **2** to the specified tightening torque.

 Brake caliper to telescopic fork
38 Nm



- Insert the ABS sensor into its bore and install screw **1**.
- Remove the adhesive tape from the wheel rim.
- Operate the brake several times until the brake pads are bedded.
- Firmly compress the front forks several times.



- Tighten right axle clamping screw **1** to the specified tightening torque.



Clamping screw (quick-release axle) in telescopic fork

19 Nm

## Removing rear wheel

- Make sure the ground is level and firm and place the motorcycle on a suitable auxiliary stand.

– with centre stand<sup>OE</sup>

- Make sure the ground is level and firm and place the motorcycle on its centre stand.◁



- Remove screw **1** and remove the speed sensor from its bore.

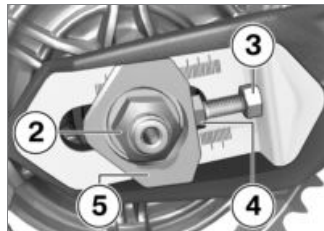

- Remove axle nut **2**.
- Slacken locknuts **3** on left and right by turning them counter-clockwise.
- Back off adjusting screws **4** on left and right by turning them counter-clockwise.
- Remove adjusting plate **5** and push the axle in as far as it will go.



- Remove quick-release axle **6** and remove adjusting plate **7**.

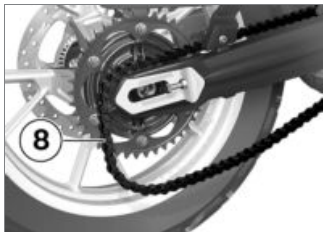

- Roll the rear wheel as far forward as possible and disengage chain **8** from the sprocket.

- Roll the rear wheel back until it is clear of the swinging arm.

#### **NOTICE**

The sprocket and the spacer sleeves on left and right are loose fits in the wheel. Take care when removing to ensure that no parts are damaged or mislaid.◀

### **Install the rear wheel**

#### **WARNING**

#### **Use of a non-standard wheel.**

Malfunctions in operation of ABS and ASC.

- See the information on the effect of wheel size on the ABS and ASC systems at the start of this chapter.◀

#### **ATTENTION**

#### **Tightening threaded fasteners to incorrect tightening torque.**

Damage, or threaded fasteners work loose.

- Always have the security of the fasteners checked by a specialist workshop, preferably an authorised BMW Motorrad dealer.◀
- Roll the rear wheel into the swinging arm, making sure that the brake disc passes between the brake pads.

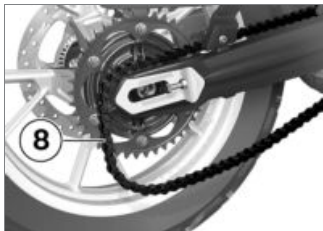

- Roll the rear wheel as far forward as possible and loop chain **8** over the sprocket.

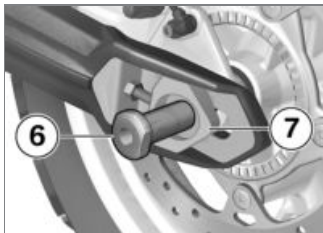

- Seat left adjusting plate **7** in the swinging arm and install quick-release axle **6** in the

brake caliper and the rear wheel.

- Make sure that the axle fits into the recess of the adjusting plate.

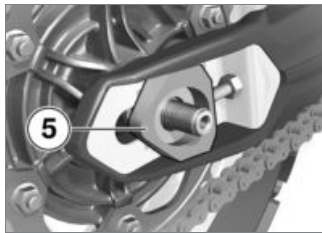

- Install right adjusting plate **5**.

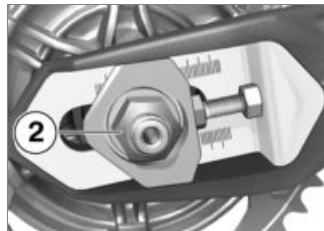

- Install nut **2**, but do not tighten it at this point.

– without centre stand<sup>OE</sup>

- Remove the auxiliary stand.<



- Insert the speed sensor into the bore and install screw **1**.

- Adjust chain sag (▮▮▮ 114).

## Front-wheel stand

### Install the front-wheel stand



#### ATTENTION

#### Use of the BMW Motorrad front wheel stand without also accompanying use of auxiliary stand.

Risk of damage to parts if vehicle topples.

- Place the motorcycle on an auxiliary stand before lifting the front wheel with the BMW Motorrad front-wheel stand.◀
- Place the motorcycle on a suitable auxiliary stand.
  - with centre stand<sup>OE</sup>
- Place the motorcycle on its centre stand.◀

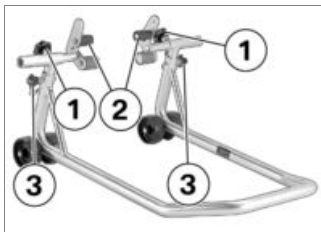

- Use basic stand (83 30 0 402 241) with front-wheel adapter (83 30 0 402 242).
- Slacken securing screws **1**.
- Push the two adapters **2** apart until the front forks fit between them. Adjust the adapter studs to suit the front suspension.
- Use locating pins **3** to set the front-wheel stand to the desired height.
- Centre the front-wheel stand relative to the front wheel and push it against the front axle.

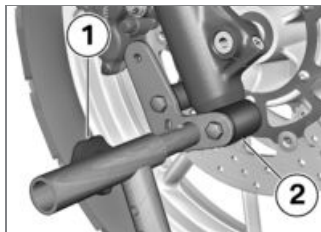

- Align the two adapters **2** so that the front forks are securely seated.
- Tighten securing screws **1**.

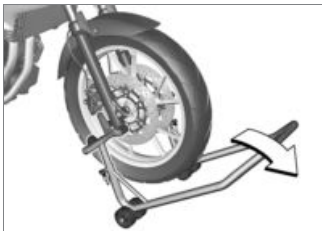

- Apply uniform pressure to push the front-wheel stand down and raise the motorcycle.

– with centre stand<sup>OE</sup>



## ATTENTION

### Centre stand retracts if vehicle lifted too high.

Risk of damage to parts if vehicle topples.

- When raising the vehicle, make sure that the centre stand remains on the ground.
- If necessary, adjust the height of the front-wheel stand.◀

- Make sure the motorcycle is standing firmly.◀

## Bulbs

### Replacing low-beam and high-beam headlight bulb

- Make sure the ground is level and firm and place the motorcycle on its stand.
- Switch off the ignition.

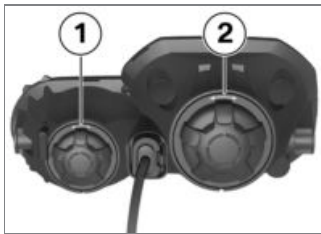

- Remove cover **1** for the high-beam headlight or cover **2** for the low-beam headlight.

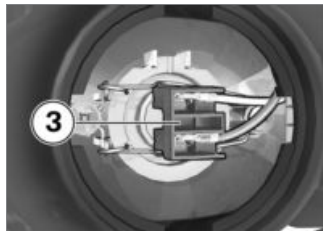

- Disconnect plug **3**.

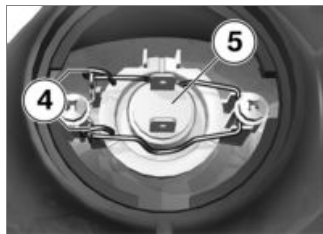

- Disengage spring clips **4** from the fastenings and swing them aside.
- Remove bulb **5**.

- Replace the defective bulb.

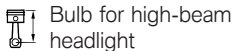

Bulb for high-beam headlight

H7 / 12 V / 55 W

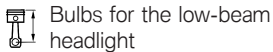

Bulbs for the low-beam headlight

H7 / 12 V / 55 W

- Hold the new bulb by the base only, in order to keep the glass free of foreign matter.

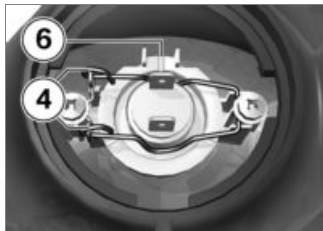

- Insert the bulb, making sure that tab **6** is correctly positioned.

- Close and lock spring clips **4**.

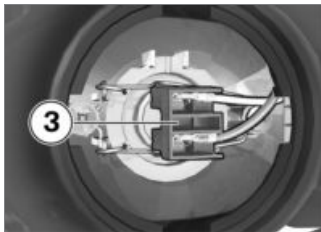

- Connect plug **3**.

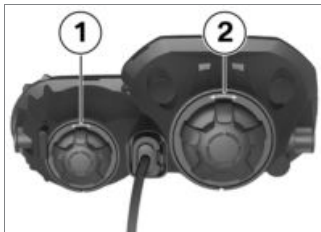

- Install cover **1** or cover **2**, as applicable.

## Replacing parking-light bulb

- Make sure the ground is level and firm and place the motorcycle on its stand.
- Switch off the ignition.



- Remove cover **2**.



- Pull socket **3** out of the headlight housing.



- Pull the bulb out of the bulb socket.

- Replace the defective bulb.



Bulb for parking light

W5W / 12 V / 5 W



- Push the bulb into the bulb socket.

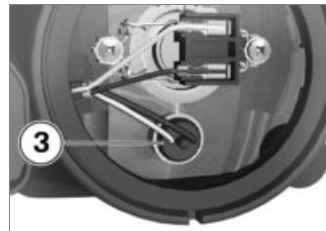

- Insert socket **3** into the headlight housing.



- Install cover **2**.

## Replacing LED for brake light and tail light

- The LED rear light can be replaced only as a complete unit. Consult a specialist workshop, preferably an authorised BMW Motorrad dealer.

## Replacing bulbs for front and rear turn indicators

– with LED turn indicators<sup>OE</sup>

- The LED flashing turn indicators can be replaced only as a complete unit. Consult a specialist workshop, preferably an authorised BMW Motorrad dealer.◀

– without LED turn indicators<sup>OE</sup>

- Make sure the ground is level and firm and place the motorcycle on its stand.
- Switch off the ignition.



- Remove screw **1**.



- Pull the glass out of the reflector housing at the threaded-fastener side.

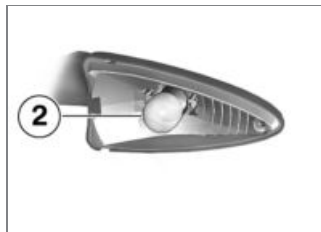

- Press bulb **2** in, turn it counter-clockwise and remove it from the bulb housing.
- Replace the defective bulb.

 Bulbs for flashing turn indicators, front

R10W / 12 V / 10 W

- Use a clean, dry cloth to hold the new bulb in order to keep the glass free of foreign matter.

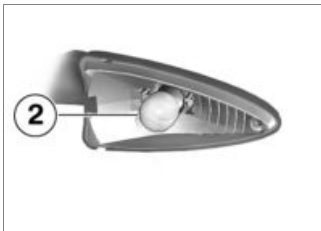

- Press bulb **2** into the bulb housing and turn it clockwise to install.



- Working from the inboard side, insert the glass into the bulb housing and close the housing.



- Install screw **1**.

### Replacing number-plate light bulbs

- Make sure the ground is level and firm and place the motorcycle on its stand.
- Switch off the ignition.



- Remove screw **1** from the mudguard cover and remove the cover.

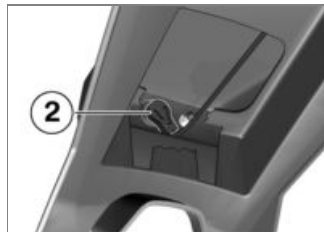

- Remove socket **2** from the bulb support.



- Remove the bulb from the socket.
- Replace the defective bulb.

 Bulb for number-plate light

W5W / 12 V / 5 W

- Use a clean, dry cloth to hold the new bulb in order to keep the glass free of foreign matter.



- Insert the bulb into the socket.

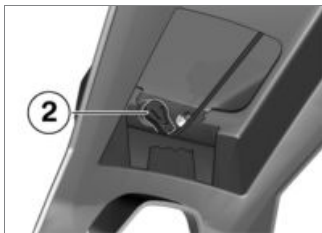

- Install socket **2** in the bulb support.



- Hold the mudguard cover in position and install screw **1**.

## Body panels

### Removing centre trim panel

- Removing seat (➡ 58).

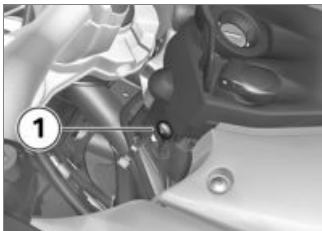

- Remove screws **1** on left and right.

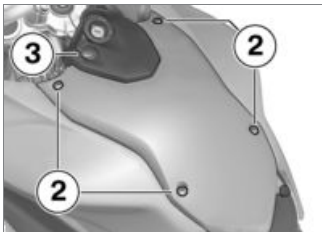

- Remove four screws **2**.
- Disconnect the plug from socket **3**.
- Remove the centre trim panel.

## Installing centre trim panel

- Connect the plug to the socket.

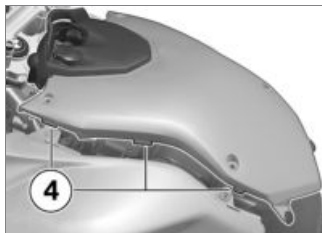

- Manoeuvre the centre trim panel into position. Make sure that all three tabs **4** on left and right engage the side panels.

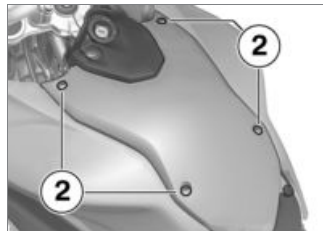

- Install four screws **2**.



- Install screws **1** on left and right.
- Installing seat (→ 58).

## Air filter

### Removing air filter

- Removing centre trim panel (➡ 129).

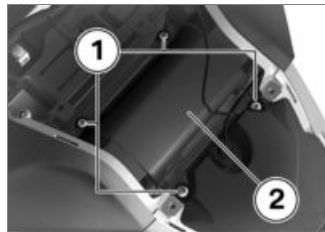

- Remove four screws **1**.
- Remove the air filter cover **2**, slightly pushing the side trim panel outwards to do so.

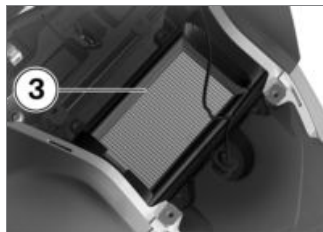

- Remove air filter **3**.

### Install air filter

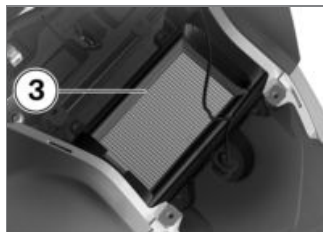

- Install air filter **3**.

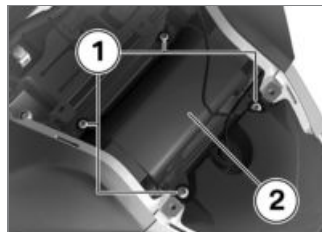

- Place air filter cover **2** in position, easing the side trim panels out slightly to do so.
- Install screws **1** with the washers.
- Installing centre trim panel (➡ 130).

### Jump-starting



#### ATTENTION

#### Excessive current flowing when the motorcycle is jump-started

Wiring smoulders/ignites or damage to the on-board electronics

- If the motorcycle has to be jump-started connect the leads to the battery terminals; never attempt to jump-start the engine by connecting leads to the on-board socket.◀



### ATTENTION

#### Contact between crocodile clips of jump leads and vehicle.

Risk of short-circuit

- Use jump leads fitted with fully insulated crocodile clips at both ends.◀



### ATTENTION

#### Jump-starting with a voltage greater than 12 V.

Damage to the on-board electronics.

- Make sure that the battery of the donor vehicle has a voltage rating of 12 V.◀

- Removing centre trim panel (▶▶▶ 129).
- When jump-starting the engine, do not disconnect the battery from the on-board electrical system.

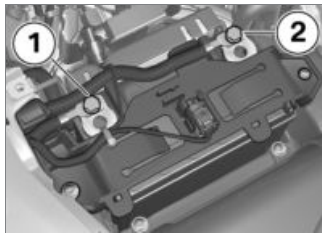

- Begin by connecting one end of the red jump lead to the positive terminal of the discharged battery and the other end to the positive terminal of the donor battery (positive on this vehicle: position **2**).
- Then connect one end of the black jump lead to the negative terminal of the donor bat-

tery and the other end to the negative terminal of the discharged battery (negative on this vehicle: position **1**).



### NOTICE

The spring-strut screw can be used as an alternative to the battery's negative terminal.◀

- Run the engine of the donor vehicle during jump-starting.
- Start the engine of the vehicle with the discharged battery in the usual way; if the engine does not start, wait a few minutes before repeating the attempt in order to protect the starter motor and the donor battery.
- Allow both engines to idle for a few minutes before disconnecting the jump leads.
- Disconnect the jump lead from the negative terminals first, then disconnect the second

lead from the positive terminals.

## NOTICE

Do not use proprietary start-assist sprays or other products to start the engine. ◀

- Installing centre trim panel (▶▶▶ 130).

## Battery

### Maintenance instructions

Correct upkeep, recharging and storage will prolong the life of the battery and are essential if warranty claims are to be considered.

Compliance with the points below is important in order to maximise battery life:

- Keep the surface of the battery clean and dry.
- Do not open the battery.
- Do not top up with water.

- Be sure to read and comply with the instructions for charging the battery on the following pages.
- Do not turn the battery upside down.

## ATTENTION

### On-board electronics (e.g. clock) draining connected battery.

Battery is deep-discharged; this voids the guarantee.

- Connect a float charger to the battery if the motorcycle is to remain out of use for more than four weeks. ◀

## NOTICE

BMW Motorrad has developed a float charger specially designed for compatibility with the electronics of your motorcycle. Using this charger, you can keep

the battery charged during long periods of disuse, without having to disconnect the battery from the motorcycle's on-board systems. You can obtain additional information from your authorised BMW Motorrad dealer. ◀

### Charge battery when connected

- Disconnect devices plugged into the sockets.

## ATTENTION

### Charging connected battery via the battery terminals.

Damage to the on-board electronics.

- Disconnect the battery at the battery terminals before charging. ◀

**ATTENTION****Unsuitable battery chargers connected to an on-board socket.**

Damage to charger and to frame and suspension electronics.

- Use suitable BMW chargers. The suitable charger is available from your authorised BMW Motorrad dealer. ◀

**ATTENTION****Charging a fully discharged battery via the on-board socket or the extra socket.**

Damage to the on-board electronics.

- If a battery has discharged to the extent that it is completely flat (battery voltage less than 9 V, status-indicator lights and multifunction display remain off when the ignition is switched on) **it has to be disconnected**

**from the on-board circuits** and re-charged with the charger connected directly to the battery posts. ◀

- Charge via the charging socket, with the battery connected to the motorcycle's on-board electrical system.

**NOTICE**

The motorcycle's on-board electronics know when the battery is fully charged. The on-board socket is switched off when this happens. ◀

- Comply with the operating instructions of the charger.

**NOTICE**

If you are unable to charge the battery through the on-board socket, you may be using a charger that is not compatible with your motorcycle's electronics. If

this happens, disconnect the battery from the on-board systems and connect the charger directly to the battery. ◀

**Charging battery when disconnected**

- Charge the battery using a suitable charger.
- Comply with the operating instructions of the charger.
- After charging, remove the pole terminal of the charger from the battery posts.

**NOTICE**

The battery has to be recharged at regular intervals in the course of a lengthy period of disuse. See the instructions for caring for your battery. Always fully recharge the battery before restoring it to use. ◀

## Removing battery

- Make sure the ground is level and firm and place the motorcycle on its stand.
  - with alarm system (DWA)<sup>OE</sup>
- If applicable, switch off the anti-theft alarm.<
- Switch off the ignition.

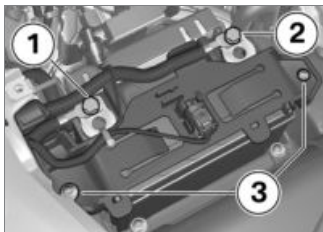

### ATTENTION

**Battery not disconnected in accordance with correct procedure.**

Risk of short-circuit

- Always proceed in compliance with the specified disconnection sequence.<
- Disconnect negative lead **1** first.
- Then disconnect positive lead **2**.
- Remove the screws **3** on left and right and pull the battery holder forward, away from the battery.
- Lift the battery up and out; work it slightly back and forth if it is difficult to remove.

## Removing battery

- Removing seat (➡ 58).
- Removing centre trim panel (➡ 129).
- Make sure the ground is level and firm and place the motorcycle on its stand.
  - with alarm system (DWA)<sup>OE</sup>
- If applicable, switch off the anti-theft alarm.<

- Switch off the ignition.

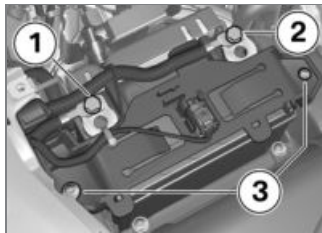

### ATTENTION

**Battery not disconnected in accordance with correct procedure.**

Risk of short-circuit

- Always proceed in compliance with the specified disconnection sequence.<
- Disconnect negative lead **1** first.
- Then disconnect positive lead **2**.

- Remove the screws **3** on left and right and pull the batter holder forward, away from the battery.
- Lift the battery up and out; work it slightly back and forth if it is difficult to remove.

## Installing battery



### NOTICE

If the battery was disconnected from the motorcycle for a prolonged period of time it will be necessary to enter the current date in the instrument panel, in order to ensure that the service-due indicator functions correctly. If you want to have the date set consult a specialist workshop, preferably an authorised BMW Motorrad dealer.◀

- Switch off the ignition.
- Insert the battery into the battery compartment, with the

positive terminal on the right in the direction of travel.

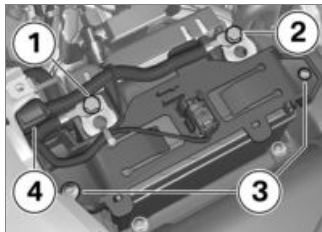

- Place the battery holder in position, making sure that the leads are correctly routed at position **4**.
- Install screws **3** on left and right.



### ATTENTION

**Battery not connected in accordance with correct procedure.**

Risk of short-circuit

- Always proceed in compliance with the specified installation sequence.◀
- Connect positive lead **2** to the battery's positive terminal.
- Connect negative lead **1** to the battery's negative terminal.
- Installing centre trim panel (▶▶▶ 130).
- Installing seat (▶▶▶ 58).
- Setting clock (▶▶▶ 41).

## Care

Care products .....	138
Washing the vehicle .....	138
Cleaning easily damaged components.....	139
Paint care .....	139
Laying up the motorcycle .....	140
Protective wax coating .....	140
Restoring motorcycle to use .....	140

## Care products

BMW Motorrad recommends that you use the cleaning and care products you can obtain from your authorised BMW Motorrad dealer. The substances in BMW Care Products have been tested in laboratories and in practice; they provide optimised care and protection for the materials used in your vehicle.



### ATTENTION

#### Use of unsuitable cleaning and care products.

Damage to vehicle parts.

- Do not use solvents such as cellulose thinners, cold cleaners, fuel or the like, and do not use cleaning products that contain alcohol. ◀

## Washing the vehicle

BMW Motorrad recommends that you use BMW insect remover to soften and wash off insects and stubborn dirt on painted parts prior to washing the motorcycle.

To prevent stains, do not wash the vehicle immediately after it has been exposed to strong sunlight and do not wash it in the sun.

Make sure that the vehicle is washed frequently, especially during the winter months.

To remove road salt, clean the motorcycle with cold water immediately after every trip.



### WARNING

#### Wet brake discs and brake pads after vehicle wash, after riding through water and in rainy conditions.

Diminished braking effect.

- Apply the brakes in good time to allow the friction and heat to dry the brake discs and brake pads. ◀



### ATTENTION

#### Effect of road salt intensified by warm water.

Corrosion

- Use only cold water to wash off road salt. ◀



### ATTENTION

#### Damage due to high water pressure from high pressure cleaners or steam cleaners.

Corrosion or short-circuit, damage to seals, to the hydraulic brake system, to the electrics and the seat.

- Exercise restraint when using a steam jet or high-pressure cleaning equipment. ◀

## Cleaning easily damaged components

### Plastics

#### ATTENTION

#### Use of unsuitable cleaning agents.

Damage to plastic surfaces.

- Do not use cleaning agents that contain alcohol, solvents or abrasives.
- Do not use insect-remover pads or cleaning pads with hard, scouring surfaces.◀

#### Body panels

Clean the trim panels with water and BMW plastic care emulsion.

#### Windscreens and lenses made of plastic

Clean off dirt and insects with a soft sponge and plenty of water.

#### NOTICE

Soften stubborn dirt and insects by covering the affected areas with a wet cloth.◀

#### Chrome

Use plenty of water and BMW shampoo to clean chrome, particularly if it has been exposed to road salt. Use chrome polish for additional treatment.

#### Radiator

Clean the radiator regularly to prevent overheating of the engine due to inadequate cooling. For example, use a garden hose with low water pressure.

#### ATTENTION

#### Radiator fins easily bent.

Damage to radiator fins.

- Take care not to bend the radiator fins when cleaning.◀

### Rubber

Treat rubber components with water or BMW rubber-care products.

#### ATTENTION

#### Application of silicone sprays to rubber seals.

Damage to the rubber seals.

- Do not use silicone sprays or care products that contain silicon.◀

### Paint care

Washing the vehicle regularly will help counteract the long-term effects of substances that can damage the paint, especially if your vehicle is ridden in areas with high air pollution or natural sources of dirt, for example tree resin or pollen.

Remove particularly aggressive substances immediately, however, as otherwise the paint can

be affected or become discoloured. Substances of this nature include spilt fuel, oil, grease, brake fluid and bird droppings. We recommend BMW vehicle polish or BMW paint cleaner for this purpose.

Marks on the paintwork are particularly easy to see after the motorcycle has been washed. Remove stains of this kind immediately, using cleaning-grade benzene or petroleum spirit on a clean cloth or ball of cotton wool. BMW Motorrad recommends BMW tar remover for removing specks of tar. Remember to wax the parts treated in this way.

## Laying up the motorcycle

- Clean the motorcycle.
- Fill the motorcycle's fuel tank.
- Removing battery (▣▶ 135).

- Spray the brake and clutch lever pivots and the main and side stand pivots with a suitable lubricant.
- Coat bright metal and chrome-plated parts with an acid-free grease (e.g. Vaseline).
- Stand the motorcycle in a dry room in such a way that there is no load on either wheel (preferably using the front-wheel and rear-wheel stands from BMW Motorrad).

## Protective wax coating

BMW Motorrad recommends applying only BMW car wax or products containing carnauba wax or synthetic wax.

It is time to rewax the paintwork when water "puddles" on the surface, instead of forming beads.

## Restoring motorcycle to use

- Remove the protective wax coating.
- Clean the motorcycle.
- Installing battery (▣▶ 136).
- Comply with checklist (▣▶ 75).

## Technical data

Troubleshooting chart .....	142
Threaded fasteners .....	143
Engine .....	145
Fuel.....	146
Engine oil .....	147
Clutch .....	148
Transmission .....	148
Rear-wheel drive.....	149
Running gear .....	149
Brakes .....	150
Wheels and tyres .....	151
Electrics .....	152
Frame .....	153
Dimensions .....	154
Weights.....	155

Riding specifications .....	155
-----------------------------	-----

## Troubleshooting chart

Engine does not start or is difficult to start:

<b>Possible cause</b>	<b>Rectification</b>
Kill switch activated	Set emergency-off switch (kill switch) to operating position.
Side stand extended and gear engaged	Select neutral or retract the side stand.
Gear engaged and clutch not disengaged	Select neutral or pull the clutch lever.
No fuel in tank	Refuelling (▮▮▮▶ 83).
Battery flat	Charge battery when connected (▮▮▶ 133).

## Threaded fasteners

Front wheel	FR	Valid
<b>Brake caliper to telescopic fork</b>		
M10 x 40	38 Nm	
<b>Clamping screw (quick-release axle) in telescopic fork</b>		
M8 x 20	19 Nm	
<b>Quick-release axle, front, in axle holder</b>		
M16 x 1.5	30 Nm	
Rear wheel	FR	Valid
<b>Locknut of the final-drive chain tensioning screw</b>		
M8	19 Nm	
<b>Rear quick-release axle in swinging arm</b>		
M16 x 1.5	100 Nm	

Mirror arm	FR	Valid
<b>Locknut (mirror) to clamping piece</b>		
M10 x 1.5 Multi-wax spray	20 Nm	
<b>Clamping piece (mirror) to clamping block</b>		
M10	30 Nm	

## Engine

Location of engine number	Crankcase, bottom right
Engine design	Two-cylinder four-stroke, DOHC, 4 valves operated by cam followers, liquid-cooled cylinders and heads, integral coolant pump, 6-speed gearbox and dry sump lubrication
Displacement	798 cm <sup>3</sup>
Cylinder bore	82 mm
Piston stroke	75.6 mm
Compression ratio	12 : 1
Nominal output	55 kW, - at engine speed: 7000 min <sup>-1</sup>
- with regular unleaded <sup>OE</sup>	52 kW, - at engine speed: 7000 min <sup>-1</sup>
- with power reduction to 35 kW <sup>OE</sup>	35 kW, - at engine speed: 7000 min <sup>-1</sup>
- with power reduction to 25 kW <sup>OE</sup>	25 kW, - at engine speed: 5000 min <sup>-1</sup>
Torque	77 Nm, - at engine speed: 5500 min <sup>-1</sup>
- with regular unleaded <sup>OE</sup>	75 Nm, - at engine speed: 4500 min <sup>-1</sup>
- with power reduction to 35 kW <sup>OE</sup>	60 Nm, - at engine speed: 5000 min <sup>-1</sup>
- with power reduction to 35 kW <sup>OE</sup> - with regular unleaded <sup>OE</sup>	58 Nm, - at engine speed: 5000 min <sup>-1</sup>
- with power reduction to 25 kW <sup>OE</sup>	57 Nm, - at engine speed: 3000 min <sup>-1</sup>

Maximum engine speed	max 9000 min <sup>-1</sup>
Idle speed	1250 <sup>+50</sup> min <sup>-1</sup> , vehicle at standstill

## Fuel

Recommended fuel grade	Super unleaded (max. 10 % ethanol, E10) 95 ROZ/RON 89 AKI
– with regular unleaded <sup>OE</sup>	Regular unleaded (slight power- and consumption-related restrictions) (max. 10 % ethanol, E10) 91 ROZ/RON 87 AKI
Usable fuel capacity	approx. 16 l
Reserve fuel	min 2.7 l
Exhaust emissions standard	EU 3



## Clutch

Clutch type	Multiplate clutch running in oil bath
-------------	---------------------------------------

## Transmission

Gearbox type	Claw-shift 6-speed transmission, integrated into engine block
Gearbox transmission ratios	1.943 (35/68 teeth), Primary transmission ratio 1:2.462 (13/32 teeth), 1st gear 1:1.750 (16/28 teeth), 2nd gear 1:1.381 (21/29 teeth), 3rd gear 1:1.174 (23/27 teeth), 4th gear 1:1.042 (24/25 teeth), 5th gear 1:0.960 (25/24 teeth), 6th gear

## Rear-wheel drive

Type of final drive	Chain drive
Type of rear suspension	Two-arm cast-aluminium swinging arm
Final drive, number of teeth (Pinion / sprocket)	17/42

## Running gear

### Front wheel

Type of front suspension	telescopic forks
Spring travel, front	170 mm, At wheel
– with lowered suspension <sup>OE</sup>	140 mm, At wheel

### Rear wheel

Type of rear suspension	Two-arm cast-aluminium swinging arm
Type of rear suspension	Direct-pivot central spring strut with steplessly adjustable rebound-stage damping
Spring travel at rear wheel	170 mm, At wheel
– with lowered suspension <sup>OE</sup>	135 mm, At wheel

## Brakes

### Front wheel

Type of front brake	Hydraulically operated twin disc brake with 2-piston floating calipers and floating brake discs
Brake-pad material, front	Sintered metal
Brake disc thickness, front	min 4.5 mm, Wear limit

### Rear wheel

Type of rear brake	Hydraulically actuated disc brake with 1-piston floating caliper and fixed disc
Brake-pad material, rear	Organic material
Brake disc thickness, rear	min 4.5 mm, Wear limit

## Wheels and tyres

Recommended tyre sets	Your authorised BMW Motorrad dealer will be happy to supply an up-to-date list of the approved wheel/tyre combinations, or you can check the information posted on the <a href="http://bmw-motorrad.com">bmw-motorrad.com</a> website.
Speed category, front/rear tyres	h, required at least: 210 km/h
<b>Front wheel</b>	
Front wheel type	Cast aluminium, MT H2
Front wheel rim size	2.50" x 19"
Tyre designation, front	110 / 80 - 19
Load index, front tyre	min. 42
Permissible front-wheel imbalance	max 5 g
<b>Rear wheel</b>	
Rear-wheel type	Cast aluminium, MT H2
Rear wheel rim size	3.50" x 17"
Tyre designation, rear	140 / 80 - 17
Load index, rear tyre	min. 66
Permissible rear-wheel imbalance	max 45 g

**Tyre pressure**

Tyre pressure, front	2.2 bar, one-up, tyre cold 2.2 bar, two-up and/or with luggage, tyre cold
Tyre pressure, rear	2.5 bar, one-up, tyre cold 2.9 bar, two-up and/or with luggage, tyre cold

**Electrics**

Electrical rating of on-board sockets	5 A
Fuses	Electronic fuses protect all the circuits. If an electronic fuse trips and de-energises a circuit, the circuit is active as soon as the ignition is switched on after the fault has been rectified.

**Battery**

Battery type	AGM (Absorbent Glass Mat) battery
Battery rated voltage	12 V
Battery rated capacity	12 Ah

**Spark plugs**

Spark plugs, manufacturer and designation	NGK DCPR 8 E
Electrode gap of spark plug	0.9 mm

**Lighting**

Bulb for high-beam headlight	H7 / 12 V / 55 W
Bulbs for the low-beam headlight	H7 / 12 V / 55 W
Bulb for parking light	W5W / 12 V / 5 W
Bulb for tail light/brake light	LED
Maximum number of defective LEDs in rear-light unit	6, Brake light/rear light
Bulb for number-plate light	W5W / 12 V / 5 W
Bulbs for flashing turn indicators, front	R10W / 12 V / 10 W
Bulbs for flashing turn indicators, rear	R10W / 12 V / 10 W

**Frame**

Frame type	Tubular spaceframe
Type plate location	Steering head, front top
Position of the Vehicle Identification Number	Frame, front right, on steering head

## Dimensions

Length of motorcycle	2280 mm, across front wheel to number-plate carrier
Height of motorcycle	1343 mm, across mirrors, without rider at unladen weight (as per DIN standard)
– with lowered suspension <sup>OE</sup>	1308 mm, across mirrors, without rider at unladen weight (as per DIN standard)
Width of motorcycle	880 mm, with mirrors
Front-seat height	820 mm, Without rider at unladen weight
– with Comfort seat <sup>OE</sup>	835 mm, Without rider at unladen weight
– with seat, low <sup>OE</sup>	790 mm, Without rider at unladen weight
– with seat, low <sup>OE</sup>	765 mm, Without rider at unladen weight
– with lowered suspension <sup>OE</sup>	
Rider's inside-leg arc, heel to heel	1810 mm, Without rider at unladen weight
– with Comfort seat <sup>OE</sup>	1840 mm, Without rider at unladen weight
– with seat, low <sup>OE</sup>	1760 mm, Without rider at unladen weight
– with seat, low <sup>OE</sup>	1710 mm, Without rider at unladen weight
– with lowered suspension <sup>OE</sup>	

## Weights

Unladen weight	209 kg, DIN unladen weight, ready for road, 90 % load of fuel, without OE
Permissible gross weight	436 kg
– with lowered suspension <sup>OE</sup>	349 kg
Maximum payload	227 kg
– with lowered suspension <sup>OE</sup>	140 kg

## Riding specifications

Starting capability on uphill gradients (at permissible gross weight)	20 %
Top speed	192 km/h
– with regular unleaded <sup>OE</sup>	189 km/h
– with power reduction to 35 kW <sup>OE</sup>	165 km/h
– with power reduction to 25 kW <sup>OE</sup>	136 km/h



## **Service**

BMW Motorrad Service .....	158
BMW Motorrad Mobility services .....	158
Maintenance work .....	158
Maintenance schedule .....	161
Standard BMW service .....	162
Confirmation of maintenance work .....	163
Confirmation of service .....	168

## BMW Motorrad Service

BMW Motorrad has an extensive network of dealerships in place to look after you and your motorcycle in more than 100 countries. Authorised BMW Motorrad dealerships have the technical information and the technical know-how to reliably carry out all maintenance and repair work on your BMW.

Visit our website [www.bmw-motorrad.com](http://www.bmw-motorrad.com) to find out where the nearest authorised BMW Motorrad dealership is located.



### WARNING

#### **Maintenance and repair work not in compliance with correct procedure.**

Risk of accident due to subsequent damage.

- BMW Motorrad recommends you to have all the associated

work on your motorcycle carried out by a specialist workshop, preferably an authorised BMW Motorrad dealer. ◀

In order to help ensure that your BMW is always in optimum condition, BMW Motorrad recommends compliance with the maintenance intervals specified for your motorcycle. Have all maintenance and repair work carried out confirmed in the "Service" chapter in this manual. For generous treatment of claims submitted after the warranty period has expired, evidence of regular maintenance is essential.

Your authorised BMW Motorrad dealer can provide information on BMW services and the work undertaken as part of each service.

## BMW Motorrad Mobility services

As owner of a new BMW motorcycle, in circumstances in which assistance is required you can benefit from the protection afforded by the various BMW Motorrad mobility services (e.g. Mobile Service, breakdown service, vehicle recovery service). Your authorised BMW Motorrad dealer will be happy provide information about the mobility services available to you.

### Maintenance work

#### **BMW Pre-delivery Check**

Your authorised BMW Motorrad dealer conducts the BMW pre-delivery check before handing over the vehicle to you.

## BMW Running-in Check

The BMW running-in check has to be performed when the vehicle has covered between 500 km and 1200 km.

## BMW Service

The BMW Service is carried out once a year; the extent of servicing can vary, depending on the age of the vehicle and the distance it has covered. Your authorised BMW Motorrad dealer confirms that the service work has been carried out and enters the date when the next service will be due.

Riders who cover long distances in a year might have to bring in their vehicles for service before the next scheduled date. It is to allow for these cases that a maximum odometer reading is entered as well in the confirmation of service. Servicing has to be brought forward if this odo-

meter reading is reached before the next scheduled date for the service.

The service-due indicator in the multifunction display reminds you about one month or 1000 km in advance when the time for a service is approaching, on the basis of the programmed values.

To find out more about service go to:

**[bmw-motorrad.com/service](http://bmw-motorrad.com/service)**

The maintenance tasks necessary for your vehicle are set out in the maintenance schedule below:



## Maintenance schedule

- 1** BMW Running-in check
- 2** Standard BMW service  
( 162)
- 3** Engine-oil change, with filter
- 4** Check valve clearance
- 5** Replace all spark plugs
- 6** Replace air-filter element
- 7** Check or replace air-filter element
- 8** Change brake fluid, entire system
  - a** annually or every 10,000 km (whichever comes first)
  - b** if vehicle is used off-road, annually or every 10,000 km (whichever comes first).
  - c** for the first time after one year, then every two years

## Standard BMW service

A standard BMW service consists of the following maintenance work:

- Perform vehicle test with the BMW Motorrad diagnosis system.
- Check the coolant level.
- Check/adjust the clutch play.
- Check the freedom of movement of the throttle cable and check for kinks and chafing
- Check the front and rear brake pads and brake discs for wear.
- Check the front and rear brake-fluid levels.
- Visually inspect the brake pipes, brake hoses and connections.
- Check the tyre pressures and tread depth.
- Check and lubricate the chain drive.
- Check the ease of movement of the side stand.
- Check the ease of movement of the centre stand (if vehicle fitted with the "centre stand" optional extra).
- Check the steering-head bearing.
- Check the lights and signalling equipment.
- Check that the engine start suppression system is in working order.
- Perform final inspection and check of roadworthiness.
- Set the service-due date and service countdown distance.
- Check the battery charge state.
- Confirm BMW service in the on-board documentation.

## Confirmation of maintenance work

### **BMW Pre-delivery Check**

Completed

on \_\_\_\_\_

\_\_\_\_\_  
Stamp, signature

### **BMW Running-in Check**

Completed

on \_\_\_\_\_

Odometer reading \_\_\_\_\_

Next service  
at the latest

on \_\_\_\_\_

or, if logged beforehand,

Odometer reading \_\_\_\_\_

\_\_\_\_\_  
Stamp, signature

**BMW Service**

Completed

on \_\_\_\_\_

Odometer reading \_\_\_\_\_

Next service  
at the latest

on \_\_\_\_\_

or, if logged beforehand,

Odometer reading \_\_\_\_\_

\_\_\_\_\_  
Stamp, signature**BMW Service**

Completed

on \_\_\_\_\_

Odometer reading \_\_\_\_\_

Next service  
at the latest

on \_\_\_\_\_

or, if logged beforehand,

Odometer reading \_\_\_\_\_

\_\_\_\_\_  
Stamp, signature**BMW Service**

Completed

on \_\_\_\_\_

Odometer reading \_\_\_\_\_

Next service  
at the latest

on \_\_\_\_\_

or, if logged beforehand,

Odometer reading \_\_\_\_\_

\_\_\_\_\_  
Stamp, signature

**BMW Service**

Completed

on \_\_\_\_\_

Odometer reading \_\_\_\_\_

Next service  
at the latest

on \_\_\_\_\_

or, if logged beforehand,

Odometer reading \_\_\_\_\_

\_\_\_\_\_  
Stamp, signature**BMW Service**

Completed

on \_\_\_\_\_

Odometer reading \_\_\_\_\_

Next service  
at the latest

on \_\_\_\_\_

or, if logged beforehand,

Odometer reading \_\_\_\_\_

\_\_\_\_\_  
Stamp, signature**BMW Service**

Completed

on \_\_\_\_\_

Odometer reading \_\_\_\_\_

Next service  
at the latest

on \_\_\_\_\_

or, if logged beforehand,

Odometer reading \_\_\_\_\_

\_\_\_\_\_  
Stamp, signature

**BMW Service**

Completed

on \_\_\_\_\_

Odometer reading \_\_\_\_\_

Next service  
at the latest

on \_\_\_\_\_

or, if logged beforehand,

Odometer reading \_\_\_\_\_

\_\_\_\_\_  
Stamp, signature**BMW Service**

Completed

on \_\_\_\_\_

Odometer reading \_\_\_\_\_

Next service  
at the latest

on \_\_\_\_\_

or, if logged beforehand,

Odometer reading \_\_\_\_\_

\_\_\_\_\_  
Stamp, signature**BMW Service**

Completed

on \_\_\_\_\_

Odometer reading \_\_\_\_\_

Next service  
at the latest

on \_\_\_\_\_

or, if logged beforehand,

Odometer reading \_\_\_\_\_

\_\_\_\_\_  
Stamp, signature

**BMW Service**

Completed

on \_\_\_\_\_

Odometer reading \_\_\_\_\_

Next service  
at the latest

on \_\_\_\_\_

or, if logged beforehand,

Odometer reading \_\_\_\_\_

\_\_\_\_\_  
Stamp, signature**BMW Service**

Completed

on \_\_\_\_\_

Odometer reading \_\_\_\_\_

Next service  
at the latest

on \_\_\_\_\_

or, if logged beforehand,

Odometer reading \_\_\_\_\_

\_\_\_\_\_  
Stamp, signature**BMW Service**

Completed

on \_\_\_\_\_

Odometer reading \_\_\_\_\_

Next service  
at the latest

on \_\_\_\_\_

or, if logged beforehand,

Odometer reading \_\_\_\_\_

\_\_\_\_\_  
Stamp, signature

## Confirmation of service

The table is intended as a record of maintenance and repair work, the installation of optional accessories and, if appropriate, special campaign (recall) work.

Item	Odometer reading	Date

Item	Odometer reading	Date



## Appendix

Certificate for electronic immobiliser .....	172
Certificate for tyre pressure monitoring (Reifendruck-Control, RDC) .....	174

## FCC Approval

### Ring aerial in the ignition switch



To verify the authorization of the ignition key, the electronic immobilizer exchanges information with the ignition key via the ring aerial.

This device complies with Part 15 of the FCC rules. Operation is subject to the following two conditions:

- (1) This device may not cause harmful interference, and
- (2) this device must accept any interference received, including interference that may cause undesired operation.



Any changes or modifications not expressly approved by the party responsible for compliance could void the user's authority to operate the equipment. ◀

## Approbation de la FCC

### Antenne annulaire présente dans le commutateur d'allumage



Pour vérifier l'autorisation de la clé de contact, le système d'immobilisation électronique échange des

informations avec la clé de contact via l'antenne annulaire.

Le présent dispositif est conforme à la partie 15 des règles de la FCC. Son utilisation est soumise aux deux conditions suivantes :

- (1) Le dispositif ne doit pas produire d'interférences nuisibles, et
- (2) le dispositif doit pouvoir accepter toutes les interférences extérieures, y compris celles qui pourraient provoquer une activation inopportune.



Toute modification qui n'aurait pas été approuvée expressément par l'organisme responsable de l'homologation peut annuler l'autorisation accordée à l'utilisateur pour utiliser le dispositif. ◀

## Certification Tire Pressure Control (TPC)

---

FCC ID: MRXBC54MA4  
IC: 2546A-BC54MA4

FCC ID: MRXBC5A4  
IC: 2546A-BC5A4

This device complies with Part 15 of the FCC Rules and with Industry Canada license-exempt RSS standard(s).

Operation is subject to the following two conditions:

- (1) This device may not cause harmful interference, and
- (2) This device must accept any interference received, including interference that may cause undesired operation.

Le présent appareil est conforme aux CNR d'Industrie Canada applicables aux appareils radio exempts de licence. L'exploitation est autorisée aux deux conditions suivantes:

- (1) l'appareil ne doit pas produire de brouillage, et
- (2) l'utilisateur de l'appareil doit accepter tout brouillage radioélectrique subi, même si le brouillage est susceptible d'en compromettre le fonctionnement.

**WARNING:** Changes or modifications not expressly approved by the party responsible for compliance could void the user's authority to operate the equipment. The term "IC:" before the radio certification number only signifies that Industry Canada technical specifications were met.

- A**  
Abbreviations and symbols, 6  
ABS  
  Control, 16  
  Engineering details, 88  
  Operation, 48  
  Self-diagnosis, 77  
  Warnings, 34  
Accessories  
  General instructions, 94  
Actuality, 7  
Air filter  
  Installation, 131  
  Position on the vehicle, 15  
  Removal, 131  
Alarm  
  triggering, 64  
Alarm function  
  Deactivating, 65  
  Motion sensor, activating, 63  
Ambient temperature  
  Outside temperature  
  warning, 34  
  Reading, 26
- ASC  
  Control, 16  
  Engineering details, 90  
  Operation, 49  
  Self-diagnosis, 78  
  Warnings, 35  
Average values  
  Resetting, 43
- B**  
Battery  
  change, 70  
  Charging battery when  
  connected, 133  
  Charging battery when  
  disconnected, 134  
  Installation, 136  
  Maintenance instructions, 133  
  Position on the vehicle, 15  
  Removal, 135  
  Technical data, 152

- Brake fluid  
  Checking fluid level, front, 109  
  Checking fluid level, rear, 110  
  Reservoir, front, 13  
  Reservoir, rear, 13  
Brake pads  
  Checking front, 107  
  Checking rear, 108  
  Running in, 78  
Brakes  
  Adjusting handlebar lever, 51  
  Checking operation, 107  
  Safety instructions, 81  
  Technical data, 150
- C**  
Cases  
  Operation, 95  
Chain  
  Adjusting sag, 114  
  Checking sag, 113  
  Checking wear, 114  
  Lubricating, 113  
Checklist, 75

- Clock
  - adjusting, 41
  - Control, 18
- Clutch
  - Adjusting handlebar lever, 50
  - Adjusting play, 112
  - Checking operation, 111
  - Checking play, 112
  - Technical data, 148
- Confirmation of maintenance work, 163
- Coolant
  - Checking fill level, 111
  - Fill-level indicator, 13
  - Topping up, 111
  - Warning for overtemperature, 32
- D**
- Damping
  - Adjuster, 13
  - adjusting, 53
- Deactivating
  - Alarm, 65
  - Motion sensor, 64
- Default settings, 66
- Dimensions
  - Technical data, 154
- DWA
  - Telltale light, 18
  - Warnings, 34
- E**
- Electrics
  - Technical data, 152
- Emergency off switch (kill switch), 17
  - Operation, 47
- Engine
  - starting, 76
  - Technical data, 145
  - Warning for engine electronics, 33
- Engine oil
  - Checking fill level, 105
  - Filler neck, 11
  - Oil dipstick, 11
  - Technical data, 147
  - Topping up, 106
- Equipment, 7
- ESA
  - Control, 16
  - Operation, 55
- F**
- First-aid kit
  - Stowage, 14
- Frame
  - Technical data, 153
- Front-wheel stand
  - Installing, 123
- Fuel
  - Filler neck, 13
  - Fill-level indicator, 25
  - Refuelling, 83
  - Reserve volume, 25
  - Technical data, 146
- Fuel reserve
  - Warning, 32
- Fuses, 152

**G**

- General views
  - Instrument panel, 18
  - Left side of vehicle, 11
  - Multifunction display, 22
  - Multifunction switch, left, 16
  - Right handlebar fitting, 17
  - Right side of motorcycle, 13
  - Underneath the seat, 14
  - Underneath the trim panel, 15
  - Warning and telltale lights, 24

**H**

- Hazard warning flashers
  - Control, 16
  - Operation, 46
- Headlight
  - Adjusting headlight beam throw, 57
  - Adjustment for driving on left/driving on right, 57
  - Beam throw, 57
- Heated handlebar grips
  - Control, 17
  - Operation, 47

- Helmet holder
  - Helmet, securing, 58
  - Position on the motorcycle, 14
- Horn, 16

**I**

- Ignition
  - Switching off, 40
  - Switching on, 40
- Immobiliser
  - Reserve key, 41
  - Warning, 32
- Instrument panel
  - Ambient-light brightness sensor, 18
  - Overview, 18

**J**

- Jump starting, 131

**K**

- Keys, 40

**L**

- Lighting
  - Replacing brake and tail light bulb, 127
  - Replacing high-beam headlight bulb, 124
  - Replacing low-beam headlight bulb, 124
  - Replacing number-plate light bulbs, 128
  - Replacing side-light bulb, 125
  - Replacing turn indicator bulbs, 127
  - Technical data, 153
  - Warning for bulb failure, 33
- Lights
  - Control, 16
  - Headlight flasher, operating, 45
  - High-beam headlight, operating, 45
  - Low-beam headlight, 45
  - Parking lights, operating, 45
  - Side light, 45
- Lowered suspension
  - Restrictions, 72

## Luggage

- Instructions for loading, 72

- Lashing, 95

**M**

## Maintenance

- General instructions, 104

- Maintenance schedule, 161

- Maintenance intervals, 158

## Mirrors

- adjusting, 52

- Mobility services, 158

## Motion sensor

- Deactivating, 64

## Motorcycle

- Care, 137

- Cleaning, 137

- Lashing, 84

- Laying up, 140

- Parking, 82

- Multifunction display, 18

- Control, 16

- Meaning of symbols, 23

- Overview, 22

- Select display, 42

## Multifunction switch

- General view, left side, 16

- General view, right side, 17

**O**

## Odometer

- Control, 18

- Resetting, 43

- Off-roading, 80

**P**

- Parking, 82

## Power socket

- Notes on use, 94

- Position on the vehicle, 11

- Pre-Ride-Check, 76

- Programming, 66

**R**

## RDC

- Adhesive label for rim, 116

- Engineering details, 91

- Reading, 26

- Warnings, 36

- Rear-wheel drive

- Technical data, 149

## Redline warning

- Switching on, 79

- Warning light, 18

- Refuelling, 83

## Registration

- Remote control, 68

- Remote control registration, 68

- synchronising, 69

- Rev. counter, 18

## Rider's Manual

- Position on the motorcycle, 14

- Stowage, 59

## Running gear

- Technical data, 149

- Running in, 78

**S**

## Safety instructions

- For brake, 81

- For riding, 72

## Seat

- Installation, 58

- Lock, 11

- Removal, 58

- Service, 158
- Service-due indicator, 25
- Spark plugs
  - Technical data, 152
- Speedometer, 18
- Spring preload
  - Adjuster, 13
  - adjusting, 52
  - Tools, 14
- Starting, 76
  - Control, 17
- Steering lock
  - Locking, 40
- Stopwatch
  - Operation, 43
- Symbols
  - Meaning, 23

## T

- Technical data
  - Battery, 152
  - Brakes, 150
  - Bulbs, 153
  - Clutch, 148
  - Dimensions, 154

- Electrics, 152
- Engine, 145
- Engine oil, 147
- Frame, 153
- Fuel, 146
- Rear-wheel drive, 149
- Running gear, 149
- Spark plugs, 152
- Standards, 7
- Transmission, 148
- Weights, 155
- Wheels and tyres, 151
- Telltale lights
  - Overview, 24
- Toolkit
  - Contents, 104
  - Position on the motorcycle, 14
- Topcase
  - Operation, 99
- Torques, 143
- Transmission
  - Technical data, 148

- Trim panels
  - Installing centre trim panel, 130
  - Removing centre trim panel, 129
- Troubleshooting chart, 142
- Turn indicators
  - Control, 16
  - Operation, 46
- Type plate
  - Position on the motorcycle, 13
- Tyres
  - Checking inflation pressure, 56
  - Checking tread depth, 113
  - Pressures, 152
  - Recommendation, 115
  - Running in, 79
  - Table of tyre pressures, 14
  - Technical data, 151
  - Top speed, 73

## V

- Vehicle
  - Restoring to use, 140
- Vehicle Identification Number
  - Position on the motorcycle, 13

**W**

Warning lights

Overview, 24

Warnings

ABS, 34

Anti-theft alarm, 34

ASC, 35

Bulb defect, 33

Coolant temperature, 32

Engine electronics, 33

Fuel reserve, 32

Immobiliser, 32

Mode of presentation, 27

Outside temperature

warning, 34

RDC, 36

Warnings, overview, 29

Weights

Payload table, 14

Technical data, 155

Wheels

Change of size, 115

Checking rims, 112

Install the rear wheel, 121

Installing front wheel, 118

Removing front wheel, 116

Removing rear wheel, 120

Technical data, 151



Details described or illustrated in this booklet may differ from the vehicle's actual specification as purchased, the accessories fitted or the national-market specification. No claims will be entertained as a result of such discrepancies.

Dimensions, weights, fuel consumption and performance data are quoted to the customary tolerances.

The right to modify designs, equipment and accessories is reserved.

Errors and omissions excepted.

© 2015 Bayerische Motoren Werke Aktiengesellschaft  
80788 Munich, Germany  
Not to be reproduced by any means whatsoever, wholly or in part, without the written permission of BMW Motorrad, After Sales.

Original rider's manual, printed in Germany.

## Important data for refuelling:

<b>Fuel</b>	
Recommended fuel grade	Super unleaded (max. 10 % ethanol, E10) 95 ROZ/RON 89 AKI
– with regular unleaded <sup>OE</sup>	Regular unleaded (slight power- and consumption-related restrictions) (max. 10 % ethanol, E10) 91 ROZ/RON 87 AKI
Usable fuel capacity	approx. 16 l
Reserve fuel	min 2.7 l
<b>Tyre pressure</b>	
Tyre pressure, front	2.2 bar, one-up, tyre cold 2.2 bar, two-up and/or with luggage, tyre cold
Tyre pressure, rear	2.5 bar, one-up, tyre cold 2.9 bar, two-up and/or with luggage, tyre cold

For further information on all aspects of your motorcycle, visit [bmw-motorrad.com](http://bmw-motorrad.com)

**BMW recommends** **ADVANTEC**  
ORIGINAL BMW ENGINE OIL

Order No.: 01 41 8 559 331  
08.2015, 4th edition, 01

