



BMW Motorrad



The Ultimate  
Riding Machine

Rider's Manual  
**F800GT Special vehicle**

## Vehicle data/dealership details

### Vehicle data

---

Model

---

Vehicle Identification Number

---

Colour code

---

Date of first registration

---

Registration number

### Dealership details

---

Person to contact in Service department

---

Ms/Mr

---

Phone number

---

Dealership address/phone number (company stamp)

## **Welcome to BMW**

We congratulate you on your choice of a vehicle from BMW Motorrad and welcome you to the community of BMW riders. Familiarise yourself with your new vehicle so that you can ride it safely and confidently in all traffic situations.

### **About this Rider's Manual**

Please read this Rider's Manual carefully before starting to use your new BMW. It contains important information on how to operate the controls and how to make the best possible use of all your BMW's technical features. In addition, it contains information on maintenance and care to help you maintain your vehicle's reliability and safety, as well as its value.

### **Suggestions and criticism**

If you have questions concerning your motorcycle, your authorised BMW Motorrad dealer will gladly provide advice and assistance.

We hope you will enjoy riding your BMW and that all your journeys will be pleasant and safe

BMW Motorrad.

01 41 8 565 551



# Table of Contents

<b>1 General instructions .... 5</b>	Multifunction switch, right ..... 24	Stopwatch..... 50
Overview ..... 6	Multifunction switch, right, with optional extras..... 25	Lights ..... 51
Abbreviations and symbols ..... 6	Instrument panel ..... 26	Turn indicators ..... 52
Equipment ..... 7	<b>3 Status indicators ..... 27</b>	Hazard warning flashers ..... 53
Technical data ..... 7	Warning and telltale lights ..... 28	Light signals..... 53
Actuality..... 7	Multifunction display ..... 29	Sound signals ..... 55
<b>2 General views ..... 9</b>	Warnings ..... 30	Emergency off switch (kill switch) ..... 57
General view, left side ..... 11	On-board computer display ..... 40	Heated handlebar grips ..... 57
General view, left side, with optional extras..... 13	Fuel level..... 40	BMW Motorrad ASC ..... 58
General view, right side ..... 15	Fuel reserve..... 41	Clutch ..... 59
General view, right side, with optional extras..... 17	Service-due indicator..... 41	Brakes ..... 60
Underneath the seat ..... 18	Ambient temperature..... 42	Mirrors ..... 61
Underneath the seat with optional extras..... 19	Tyre pressure ..... 43	Spring preload ..... 61
Underneath the centre trim panel ..... 20	<b>4 Operation..... 45</b>	Damping ..... 62
Multifunction switch, left .... 21	Ignition switch/steering lock ..... 46	Electronic Suspension Adjustment (ESA) ..... 63
Multifunction switch, left, with optional extras..... 22	Electronic immobiliser ..... 47	Tyres..... 64
	Clock..... 47	Headlight..... 64
	Reading ..... 48	Seat..... 65
		Helmet holder ..... 67

<b>5 Anti-theft alarm</b>		<b>7 Engineering details.....</b>	<b>93</b>	<b>9 Accessories .....</b>	<b>131</b>
<b>DWA .....</b>	<b>69</b>	Brake system with		General instructions .....	132
Overview .....	70	BMW Motorrad ABS .....	94	Power sockets .....	132
Activation .....	70	Electronic engine manage-		Cases .....	133
Alarm function.....	72	ment with BMW Motorrad		Case for special vehicle ...	136
Deactivation .....	73	ASC .....	96	Topcase.....	137
Programming.....	74	Tyre pressure monitoring		Two-way radio box .....	140
Registration of the remote		(RDC) .....	97	Fire extinguisher.....	140
control .....	76	<b>8 Maintenance .....</b>	<b>99</b>	<b>10 Care .....</b>	<b>143</b>
Synchronising .....	77	General instructions .....	100	Care products.....	144
Battery .....	78	Toolkit.....	100	Washing the vehicle.....	144
<b>6 Riding.....</b>	<b>79</b>	Engine oil .....	101	Cleaning easily damaged	
Safety instructions .....	80	Brake system .....	102	components.....	145
Comply with checklist .....	82	Coolant.....	106	Paint care .....	146
Starting.....	82	Clutch.....	107	Laying up the motor-	
Twistgrip brake.....	85	Rims and tyres .....	108	cycle .....	146
Running in .....	86	Wheels .....	109	Protective wax coating ...	146
Redline warning .....	86	Front-wheel stand.....	114	Restoring motorcycle to	
Brakes .....	87	Rear-wheel stand .....	116	use .....	146
Parking your motorcycle ...	88	Bulbs.....	117	<b>11 Technical data .....</b>	<b>147</b>
Refuelling .....	89	Fuses .....	122	Troubleshooting chart.....	148
Fuel grade .....	91	Body panels.....	123	Threaded fasteners .....	149
Securing motorcycle for		Jump-starting .....	124	Engine .....	150
transportation .....	91	Battery .....	125	Fuel .....	151
				Engine oil .....	151

Clutch .....	152	<b>13 Appendix.....</b>	<b>175</b>
Transmission.....	152	Certificate for electronic	
Rear-wheel drive .....	153	immobiliser .....	176
Running gear.....	153	Certificate for tyre pressure	
Brakes .....	154	monitoring (Reifendruck-	
Wheels and tyres.....	154	Control, RDC) .....	178
Electrics.....	156	<b>14 Index .....</b>	<b>179</b>
Frame .....	158		
Dimensions .....	159		
Weights .....	160		
Riding specifications .....	160		
<b>12 Service .....</b>	<b>161</b>		
BMW Motorrad Service ...	162		
BMW Motorrad Mobility			
services .....	162		
Maintenance work.....	162		
Maintenance schedule ....	165		
Standard BMW service....	166		
Confirmation of mainten-			
ance work .....	167		
Confirmation of service....	172		

## **General instructions**

Overview .....	6
Abbreviations and symbols .....	6
Equipment .....	7
Technical data .....	7
Actuality .....	7

## Overview

An important aspect of this Rider's Manual is that it can be used for quick and easy reference. Consulting the extensive index at the end of this Rider's Manual is the fastest way to find information on a particular topic or item. Chapter 2 will provide you with an initial overview of your motorcycle. All the necessary maintenance and servicing work on the motorcycle is documented in Chapter 11. This record of the maintenance work you have had performed on your motorcycle is a precondition for generous treatment of goodwill claims. When the time comes to sell your BMW please remember to hand over this Rider's Manual; it is an important part of the motorcycle.

## Abbreviations and symbols



**CAUTION** Low-risk hazard. Non-avoidance can lead to slight or moderate injury.



**WARNING** Medium-risk hazard. Non-avoidance can lead to fatal or severe injury.



**DANGER** High-risk hazard. Non-avoidance leads to fatal or severe injury.





**ATTENTION** Special notes and precautionary measures. Non-compliance can lead to damage to the vehicle or accessory and, consequently, to voiding of the warranty.



**NOTICE** Specific instructions on how to operate, control, adjust or look after items of equipment on the vehicle.



Indicates the end of an item of information.

- Instruction.
- » Result of an activity.
- ➔ Reference to a page with more detailed information.
- ◁ Indicates the end of a passage relating to specific accessories or items of equipment.
-  Tightening torque.
-  Technical data.
- OE Optional extras. The vehicles are assembled complete with all the BMW Motorrad optional extras originally ordered.

- OA Optional accessories. You can obtain BMW Motorrad optional accessories through your authorised BMW Motorrad dealer; optional accessories have to be retrofitted to the vehicle.
- EWS Electronic immobiliser.
- DWA Anti-theft alarm (Diebstahlwarnanlage).
- ABS Anti-lock brake system.
- ASC Automatic Stability Control.
- ESA Electronic Suspension Adjustment.
- RDC Tyre pressure monitoring.

## Equipment

When you ordered your BMW motorcycle, you chose various items of custom equipment.

This Rider's Manual describes optional extras (OE) offered by BMW and selected optional accessories (OA). This explains why the manual may also contain descriptions of equipment which you have not ordered. Please note, too, that your motorcycle might not be exactly as illustrated in this manual on account of country-specific differences. If your motorcycle contains equipment that has not been described, its description can be found in a separate manual.

## Technical data

All dimensions, weights and power ratings stated in this Rider's Manual are quoted to the standards and comply with the

tolerance requirements of the Deutsches Institut für Normung e.V. (DIN). Versions for individual countries may differ.

## Actuality

The high safety and quality level of BMW motorcycles is ensured by continuous development work on design, equipment and accessories. Because of this, your motorcycle may differ from the information supplied in the Rider's Manual. Nor can BMW Motorrad entirely rule out errors and omissions. We hope you will appreciate that no claims can be entertained on the basis of the data, illustrations or descriptions in this manual.



## General views

General view, left side.....	11
General view, left side, with optional extras .....	13
General view, right side .....	15
General view, right side, with optional extras .....	17
Underneath the seat .....	18
Underneath the seat with optional extras .....	19
Underneath the centre trim panel .....	20
Multifunction switch, left .....	21
Multifunction switch, left, with optional extras .....	22
Multifunction switch, right.....	24
Multifunction switch, right, with optional extras .....	25

Instrument panel .....	26
------------------------	----

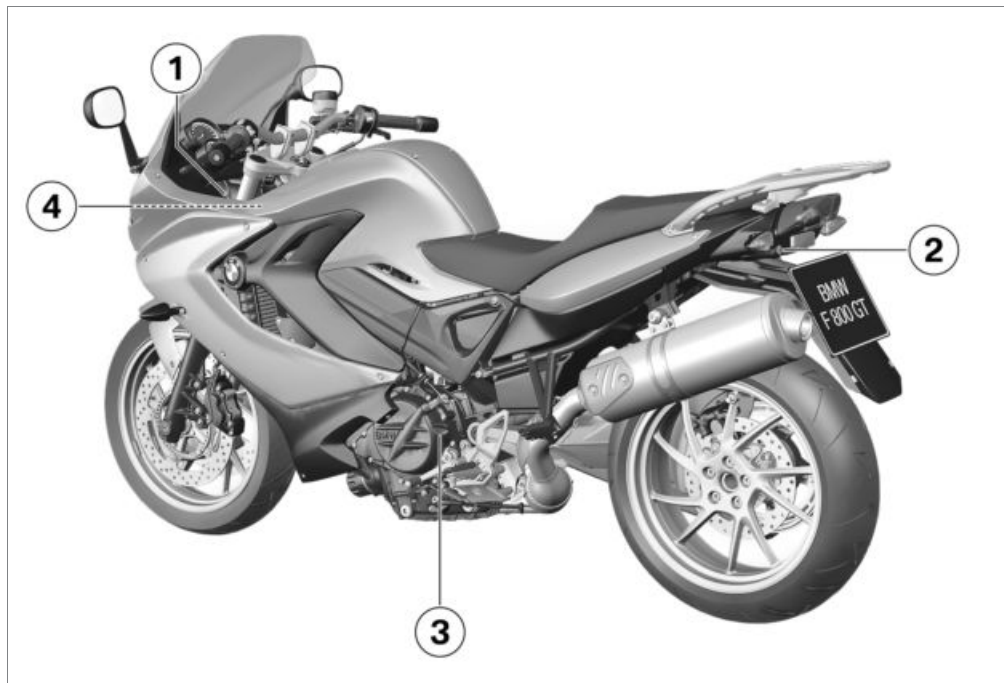

## General view, left side

- 1 Adjuster for headlight beam throw (underneath the instrument cluster) (▣▣▣▣▶ 65)
- 2 Seat lock (▣▣▣▣▶ 65)
- 3 Engine-oil filler neck and oil dipstick (▣▣▣▣▶ 101)
- 4 Payload table (on left on steering-head bearing)

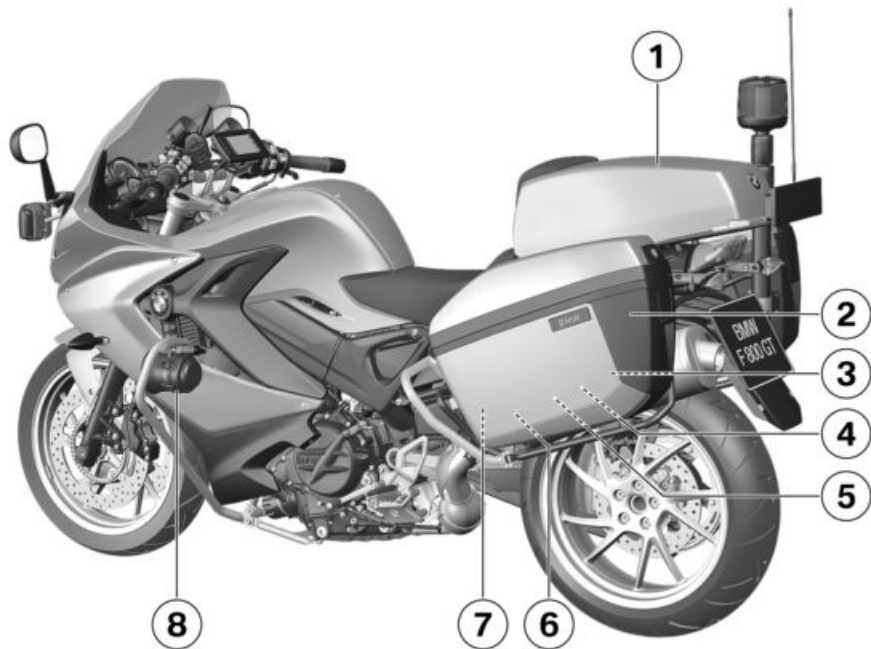

## General view, left side, with optional extras

- 1** No standard equipment
  - with single seat with two-way radio box<sup>OE</sup>Two-way radio box (►► 140)
- 2** No standard equipment
  - with cases, painted, with holder for special vehicle<sup>OE</sup>Cases (►► 136)
- 3** Standard tool kit in case  
Standard toolkit (►► 100)
- 4** Rider's Manual inside the case
- 5** Stowage in case
  - with first-aid kit<sup>OA</sup>Storing the first aid kit in case
- 6** Stowage in case
  - with service toolkit<sup>OA</sup>Location of the service toolkit (►► 100)
- 7** No standard equipment
  - with fire extinguisher complete with holder<sup>OE</sup>Fire extinguisher inside the case (►► 140)
- 8** No standard equipment
  - with electronic hailing system<sup>OE</sup>Loudspeaker for hailing system (►► 55)
  - with siren, electronic<sup>OE</sup>Loudspeaker for siren (►► 56)

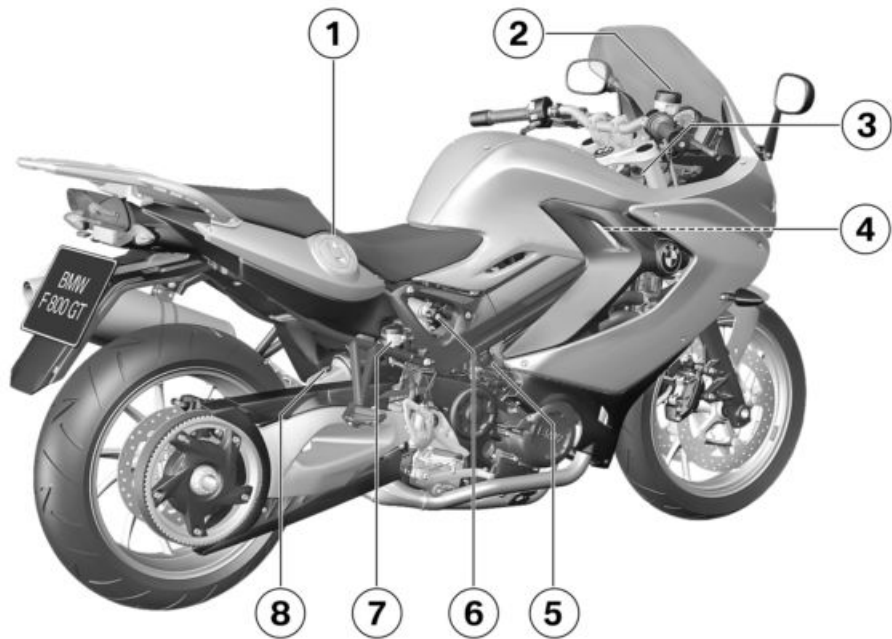

## General view, right side

- 1 Tank filler cap (►► 89)
- 2 Brake-fluid reservoir, front (►► 104)
- 3 VIN, type plate (on steering-head bearing)
- 4 Coolant level indicator (behind side panel) (►► 106)
- 5 Power socket (►► 132)
- 6 Adjuster, spring preload (►► 61)
- 7 Brake-fluid reservoir, rear (►► 105)
- 8 Adjuster for damping characteristic (►► 62)

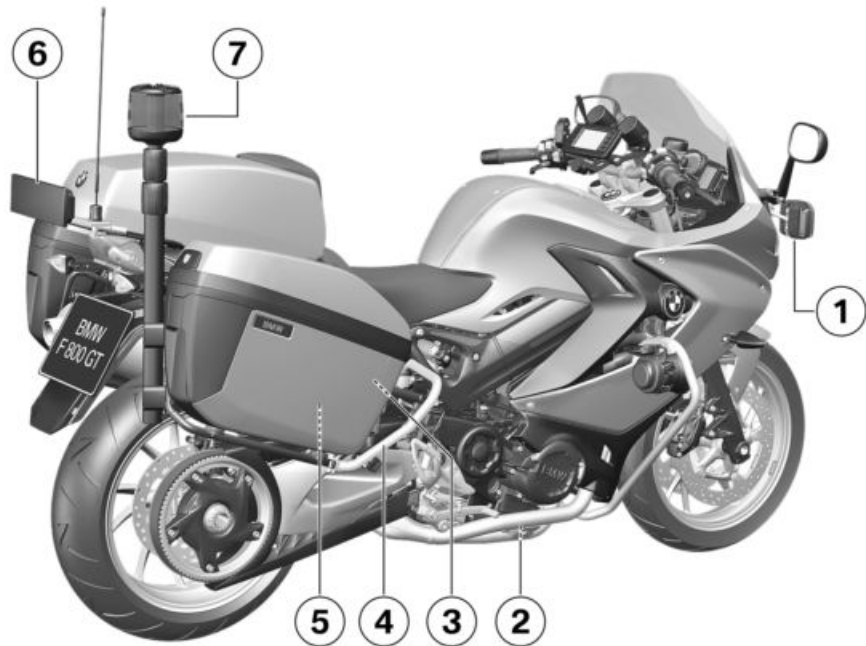

## General view, right side, with optional extras

- 1** No standard equipment  
– with LED marker  
strobe<sup>OE</sup>  
LED marker strobe (►► 53)
- 2** Crash bars
- 3** Extra socket
- 4** Rear crash bars
- 5** No standard equipment  
– with auxiliary battery<sup>OE</sup>  
Second battery inside the  
case (►► 129)
- 6** No standard equipment  
– with STOP signal<sup>OE</sup>  
STOP signal (►► 54)
- 7** No standard equipment  
– with LED 360° marker  
strobe<sup>OE</sup>  
LED 360° marker strobe  
(►► 54)

## Underneath the seat

- 1 Tool for adjusting spring preload (➡ 61)
- 2 Standard toolkit (➡ 100)
- 3 Rider's Manual
- 4 Stowage  
– with first-aid kit<sup>OA</sup>  
Location of the first-aid kit
- 5 Helmet holder (➡ 67)
- 6 Stowage  
– with service toolkit<sup>OA</sup>  
Location of the service toolkit (➡ 100)
- 7 Table of tyre pressures

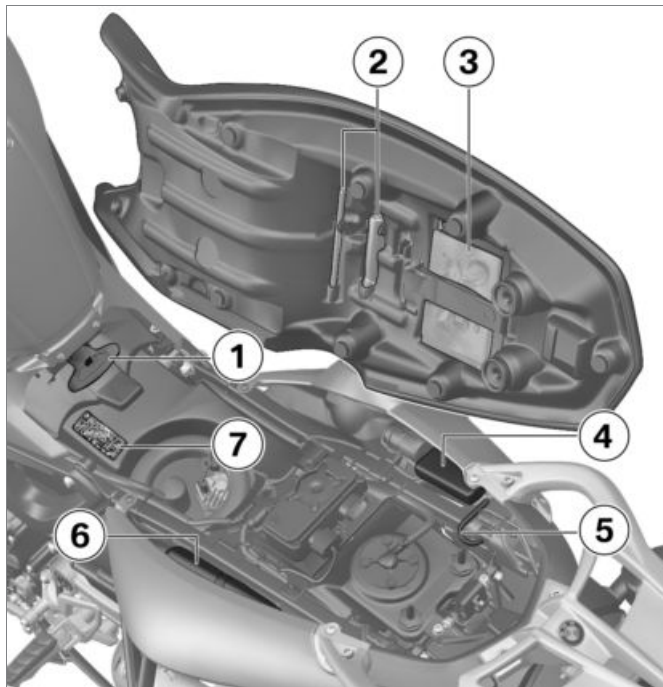

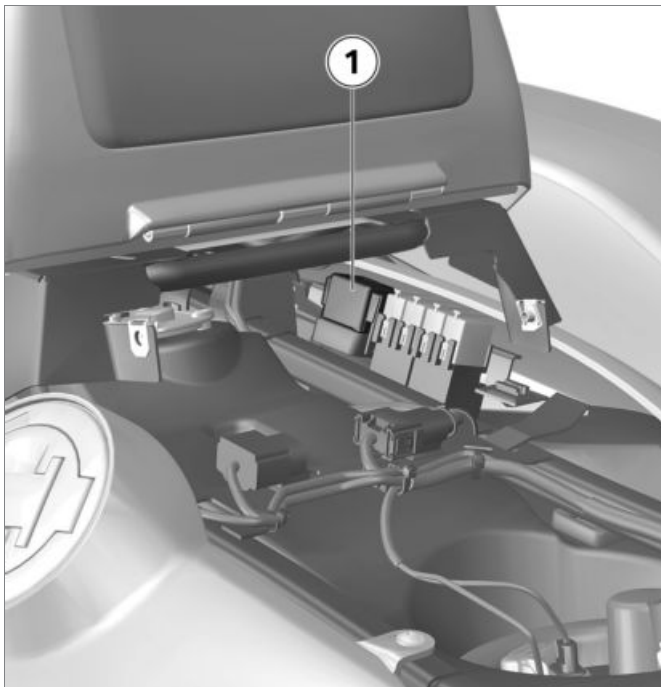

## Underneath the seat with optional extras

- 1 No standard equipment  
Fuses (➔ 122)

## Underneath the centre trim panel

- 1 Battery (🔋 125)
- 2 Stowage  
– with tyre repair kit<sup>OA</sup>  
Location of the tyre repair kit

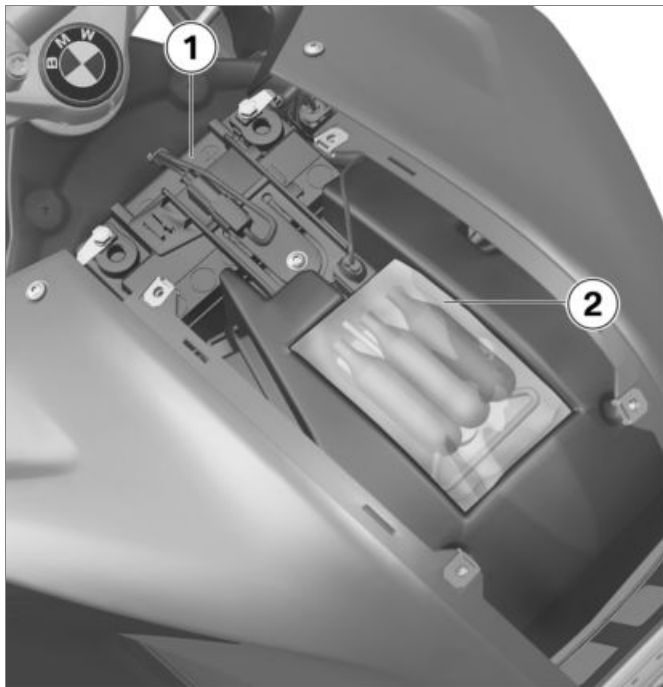

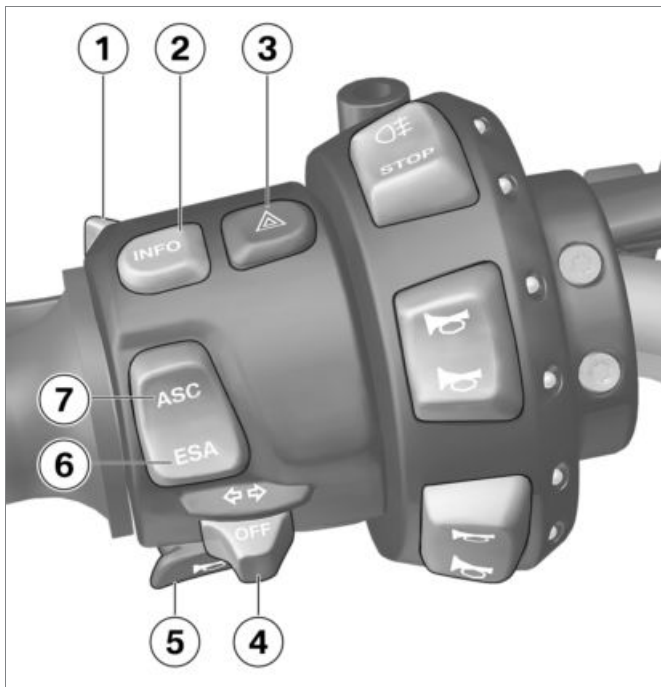

## Multifunction switch, left

- 1 High-beam headlight and headlight flasher (➡ 52)
- 2 Change of status indicators on the display (➡ 48)
- 3 Hazard warning flashers (➡ 53)
- 4 Turn indicators (➡ 52)
- 5 Horn
- 6 No standard equipment – with Electronic Suspension Adjustment (ESA)<sup>OE</sup> (➡ 63)
- 7 No standard equipment – with Automatic Stability Control (ASC)<sup>OE</sup> (➡ 58)

## Multifunction switch, left, with optional extras

- 1 No standard equipment  
– with STOP signal<sup>OE</sup>  
Stop signal with red indicator light (►► 54)
- 2 No standard equipment  
– with electronic hailing system<sup>OE</sup>  
Hailing system (►► 55)  
– with siren, electronic<sup>OE</sup>  
Siren (►► 56)
- 3 No standard equipment  
– with electronic hailing system<sup>OE</sup>  
Selection of the sound signal (►► 55)  
– with siren, electronic<sup>OE</sup>  
Selection of the siren (►► 56)
- 4 No standard equipment  
Radio button 1/2

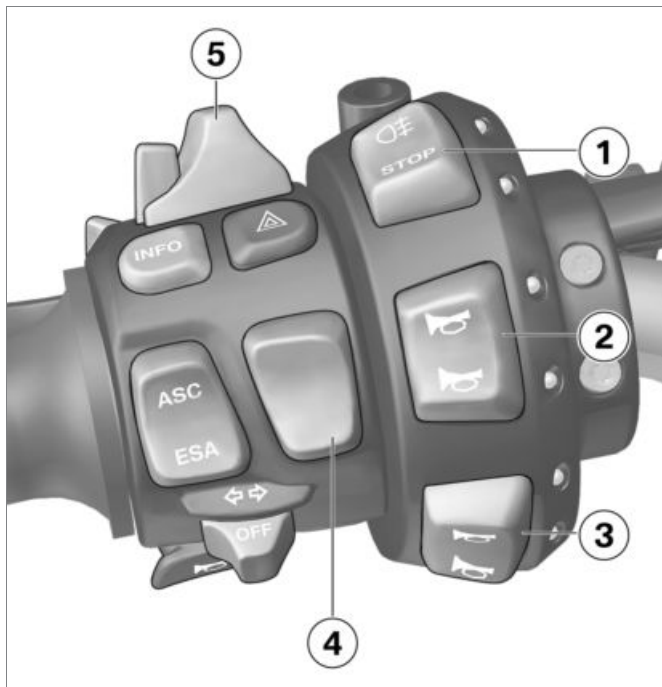

- 5** No standard equipment  
– with STOP signal<sup>OE</sup>  
Mode change of the STOP  
signal (▣→ 54)

## Multifunction switch, right

- 1 No standard equipment – with heated handlebar grips<sup>OE</sup>  
Operate the heated handlebar grips (→ 57).
- 2 Emergency off switch (kill switch) (→ 57)
- 3 Starter (→ 82)

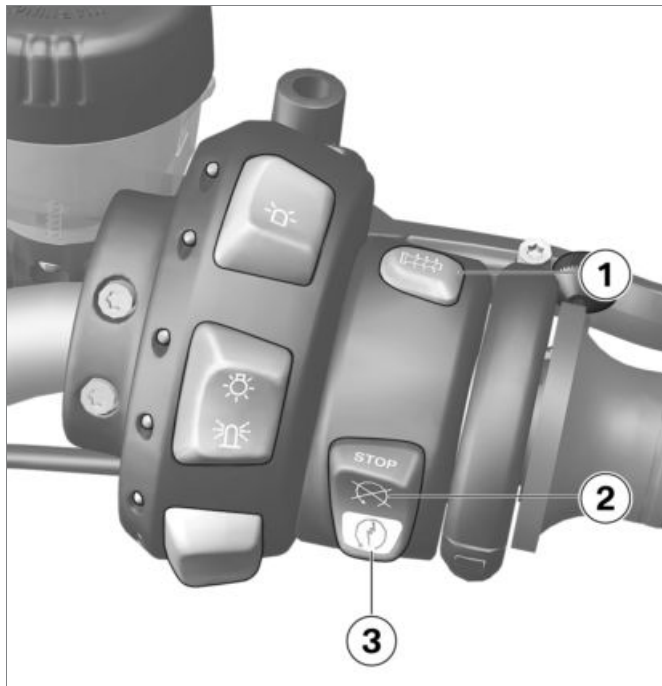

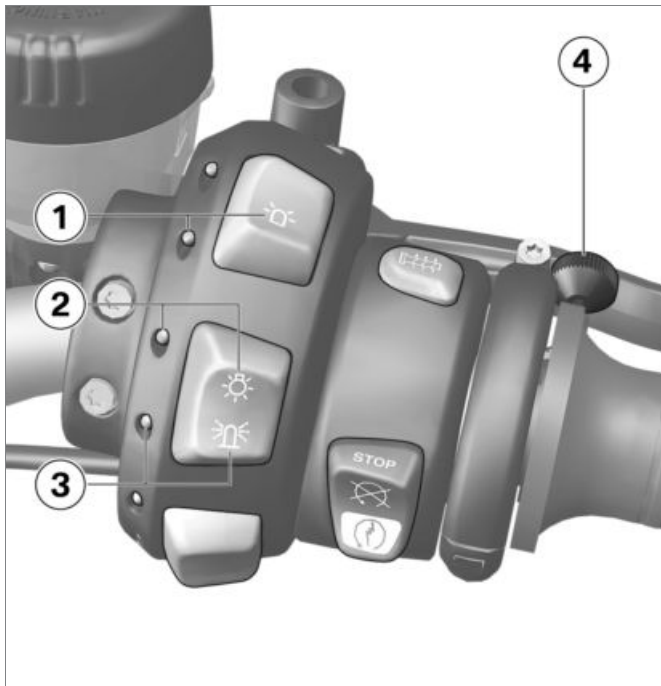

## Multifunction switch, right, with optional extras

- 1 No standard equipment  
– with LED marker strobe<sup>OE</sup>  
Marker strobes with blue indicator light (►► 53)
- 2 No standard equipment  
– with lights-off setting<sup>OE</sup>  
Lights-off setting with green indicator light (►► 55)
- 3 No standard equipment  
– with LED marker strobe<sup>OE</sup>  
360° marker strobe with blue indicator light (►► 53)
- 4 No standard equipment  
– with twistgrip brake<sup>OE</sup>  
Twistgrip brake (►► 85)

## Instrument panel

- 1 Warning and telltale lights (►► 28)
- 2 Speedometer
- 3 Function key
- 4 Multifunction display (►► 29)
- 5 Function key
- 6 Photosensor (for controlling the brightness of the instrument lighting)  
– with alarm system (DWA)<sup>OE</sup>  
Anti-theft alarm LED (see the operating instructions for the anti-theft alarm)  
– with on-board computer<sup>OE</sup>
- 7 Redline warning (►► 87)  
Rev. counter

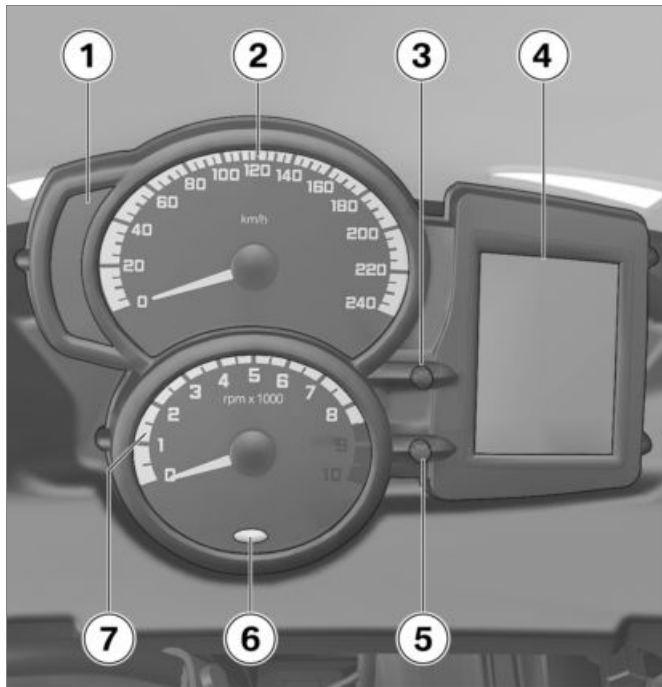

## Status indicators

Warning and telltale lights.....	28
Multifunction display .....	29
Warnings .....	30
On-board computer display .....	40
Fuel level .....	40
Fuel reserve .....	41
Service-due indicator .....	41
Ambient temperature .....	42
Tyre pressure.....	43

## Warning and telltale lights

- 28
- 1 ABS (▬▬▬▶ 39)
  - 2 No series production – with Automatic Stability Control (ASC)<sup>OE</sup> ASC (▬▬▬▶ 39)
  - 3 Fuel reserve (▬▬▬▶ 41) (▬▬▬▶ 38)
  - 4 General warning light (in combination with warnings in the display) (▬▬▬▶ 30)
  - 5 High-beam headlight
  - 6 Flashing turn indicators, right
  - 7 Idle
  - 8 Flashing turn indicators, left

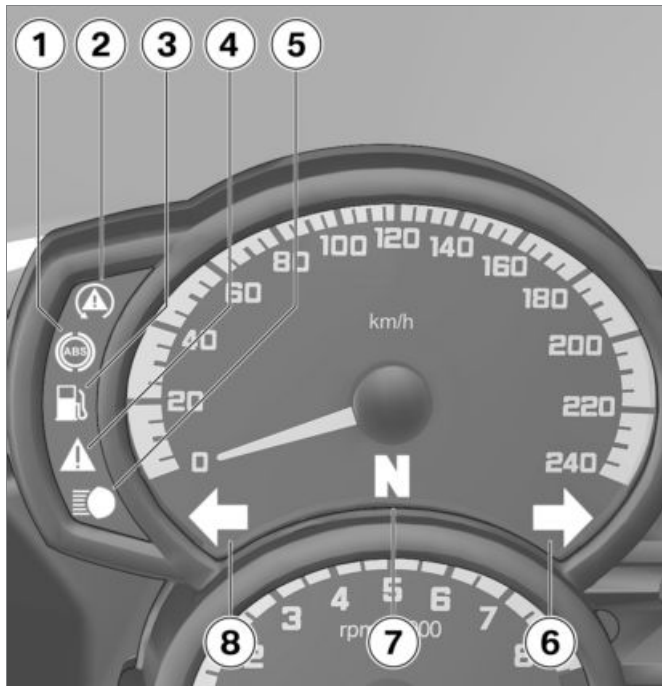

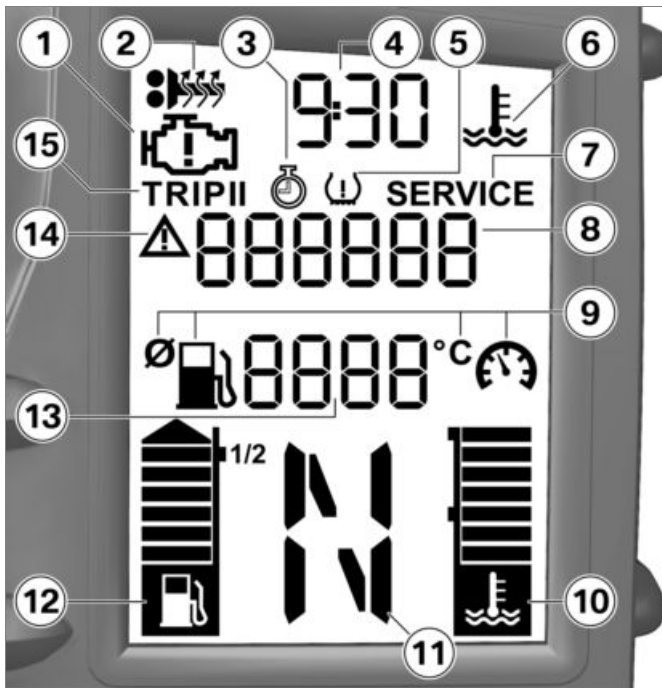

## Multifunction display

- 1 Warning for engine electronics (➡ 35)
- 2 No standard equipment – with heated handlebar grips<sup>OE</sup>  
Display showing chosen grip heating level (➡ 57)
- 3 No standard equipment – with on-board computer<sup>OE</sup>  
Stopwatch (➡ 50)
- 4 Time (➡ 47)
- 5 No standard equipment – with tyre pressure monitoring (RDC)<sup>OE</sup>  
Tyre pressure (➡ 43)
- 6 Warning for coolant temperature (➡ 34)
- 7 Serviceability (➡ 41)
- 8 Values area for status indicators (➡ 48)

- 9** No standard equipment  
– with on-board computer<sup>OE</sup>  
Symbols explaining the readings shown in the values area (➡ 40)
- 10** Coolant temperature display
- 11** No standard equipment  
– with on-board computer<sup>OE</sup>  
Gear indicator; "N" indicates neutral
- 12** Fuel level (➡ 40)
- 13** No standard equipment  
– with on-board computer<sup>OE</sup>  
Values area for status indicator (➡ 48)
- 14** Warning symbol (➡ 30)
- 15** Tripmeter (➡ 48)

## Warnings

### Mode of presentation

Warnings are indicated by the corresponding warning lights.



Warnings that do not have warning lights of their own are indicated by 'general' warning light **1** showing in combination with a text warning or a warning symbol in the multifunction display. The 'general' warning light shows yellow or red, depending on the urgency of the warning.



In addition, the warning triangle **3** can also be displayed next to the values area **2**. These warnings alternate with the tripmeter readings (➡ 48).

The status of the 'General' warning light matches the most urgent warning.

An overview of the possible warnings is listed on the next page.

## Warnings, overview

### Warning and telltale lights

### Warning symbols in the display

### Meaning

"x . x °C" flashes

Outside temperature warning (▣▣▣ 34)



lights up yellow



+ "EWS" appears on the display

Electronic immobiliser active (▣▣▣ 34)



lights up red



flashes

Coolant temperature too high (▣▣▣ 34)



lights up yellow



appears on the display

Engine in emergency-operation mode (▣▣▣ 35)



lights up yellow



+ "LAMP" appears on the display

Bulb defective (▣▣▣ 35)



lights up yellow



+ "DWA" appears on the display

DWA battery flat (▣▣▣ 36)



lights up yellow



+ "x . x" flashes

Tyre pressure close to limit of permitted tolerance (▣▣▣ 36)



flashes red













+ "x . x" flashes

Tyre pressure outside permitted tolerance (▣▣▣ 36)

## Warning and telltale lights

## Warning symbols in the display

		Warning symbols in the display	Meaning
	lights up yellow	 + "--" or "-- --" appears on the display	Sensor defective or system error (➡ 37)
	lights up yellow	 + "RdC" appears on the display.	Battery of tyre-pressure sensor weak (➡ 37)
		 + "--" or "-- --" appears on the display	Signal transmission disrupted (➡ 38)
	lights up		Fuel down to reserve (➡ 38)
	flashes		ABS self-diagnosis not completed (➡ 39)
	lights up		ABS fault (➡ 39)
	quick-flashes		ASC intervention (➡ 39)
	slow-flashes		ASC self-diagnosis not completed (➡ 39)

## Warning and telltale lights

## Warning symbols in the display

## Meaning



lights up

ASC switched off (→ 40)



lights up

ASC fault (→ 40)

## Outside temperature warning

– with on-board computer<sup>OE</sup>

"x . x °C" flashes.

Possible cause:

The air temperature measured at the vehicle is lower than 3 °C.



### WARNING

**Risk of black ice forming at temperatures above 3 °C, even though no ambient-temperature warning is issued.**

Risk of accident due to icy surface.

- Always take extra care when temperatures are low; remember that there is particular danger of black ice forming on bridges and where the road is in shade.◀
- Ride carefully and think well ahead.

## Electronic immobiliser active



General warning light shows yellow.



+ "EWS" appears on the display.

Possible cause:

The key being used is not authorised for starting, or communication between key and engine electronics is disrupted.

- Remove all other vehicle keys from the same ring as the ignition key.
- Use the reserve key.
- Have the defective key replaced, preferably by an authorised BMW Motorrad dealer.

## Coolant temperature too high



General warning light shows red.



Temperature symbol flashes.



### ATTENTION

## Riding with overheated engine.

Engine damage

- Compliance with the information set out below is essential.◀

Possible cause:

If the coolant level is too low.

- Checking coolant level (▶▶▶ 106).

If the coolant level is too low:

- Top up the coolant and have the coolant system checked by a specialist workshop, preferably by an authorised BMW Motorrad dealer.

Possible cause:

The coolant temperature is too high.

- If possible, ride in the part-load range to cool down the engine.
- If the coolant temperature is often too high, have the cooling system checked by a specialist workshop as soon as possible, preferably an authorised BMW Motorrad dealer.

### Engine in emergency-operation mode



General warning light shows yellow.



Engine symbol appears on the display.



### WARNING

**Unusual ride characteristics when engine running in emergency-operation mode.**

Risk of accident

- Adapt your style of riding accordingly.
- Avoid accelerating sharply and overtaking. ◀

Possible cause:

The engine control unit has diagnosed a fault. In exceptional cases, the engine stops and refuses to start. Otherwise, the engine runs in emergency operating mode.

- You can continue to ride, but bear in mind that the usual engine performance might not be available.
- Have the fault rectified as quickly as possible by a specialist workshop, preferably an authorised BMW Motorrad dealer.

### Bulb defective



General warning light shows yellow.



+ "LAMP" appears on the display.



### WARNING

**Failure of lights on the vehicle adds to possibility of other road users overlooking the vehicle.**

Safety risk

- Replace defective bulbs as soon as possible; always carry a complete set of spare bulbs if possible. ◀

Possible cause:

Bulb defective.

- Visually inspect to ascertain which bulb is defective.
- Replacing low-beam and/or high-beam headlight bulb (►► 117).
- Replacing bulb for parking light (►► 118).
- Replacing the brake light and rear light bulbs (►► 120).

- Remove turn indicator bulbs, front and rear (🔧 121).

## DWA battery flat

– with alarm system (DWA)<sup>OE</sup>



General warning light shows yellow.



+ "DWA" appears on the display.



### NOTICE

This error message shows briefly only after the Pre-Ride-Check completes. ◀

Possible cause:

The integral battery in the anti-theft alarm has lost its entire original capacity. There is no assurance that the anti-theft alarm will be operational if the vehicle's battery is disconnected.

- Seek the advice of a specialist workshop, preferably an authorised BMW Motorrad dealer.

## Tyre pressure close to limit of permitted tolerance

– with tyre pressure monitoring (RDC)<sup>OE</sup>



General warning light shows yellow.



+ "x . x" (critical tyre pressure) flashes.

Possible cause:

Measured tyre pressure is close to the limit of permitted tolerance.

- Correct the tyre pressure as stated on the inside cover of the Rider's Manual.



### NOTICE

Before you adjust tyre pressure, read the information on tempera-

ture compensation and adjusting pressure in the section entitled "Engineering details". ◀

## Tyre pressure outside permitted tolerance

– with tyre pressure monitoring (RDC)<sup>OE</sup>



General warning light flashes red.



+ "x . x" (critical tyre pressure) flashes.



### WARNING

## Tyre pressure outside permitted tolerance.

Impairment of the vehicle's handling characteristics.

- Adapt your style of riding accordingly. ◀

Possible cause:

Measured tyre pressure is outside permitted tolerance.

- Check the tyre for damage and to ascertain whether the vehicle can be ridden with the tyre in its present condition.

If the vehicle can be ridden with the tyre in its present condition:

- Correct the tyre pressure at the earliest possible opportunity.
- Have the tyre checked for damage by a specialist workshop, preferably an authorised BMW Motorrad dealer.

If you are unsure whether the vehicle can be ridden with the tyre in its present condition:

- Do not continue your journey.
- Notify the breakdown service.
- Have the tyre checked for damage by a specialist workshop, preferably an authorised BMW Motorrad dealer.

## Sensor defective or system error

– with tyre pressure monitoring (RDC)<sup>OE</sup>



General warning light shows yellow.



+ "--" or "--- --" appears on the display.

Possible cause:

Motorcycle is fitted with wheels not equipped with RDC sensors.

- Fit wheels and tyres equipped with RDC sensors.

Possible cause:

1 or 2 RDC sensors have failed.

- Have the fault rectified by a specialist workshop, preferably an authorised BMW Motorrad dealer.

Possible cause:

A system error has occurred.

- Have the fault rectified by a specialist workshop, preferably an authorised BMW Motorrad dealer.

## Battery of tyre-pressure sensor weak

– with tyre pressure monitoring (RDC)<sup>OE</sup>



General warning light shows yellow.



+ "RdC" appears on the display.



### NOTICE

This error message shows briefly only after the Pre-Ride-Check completes. ◀

Possible cause:

The tyre-pressure battery is almost at full capacity. There is no assurance of how long the tyre pressure control system can remain operational.

- Seek the advice of a specialist workshop, preferably an authorised BMW Motorrad dealer.

### Signal transmission disrupted

– with tyre pressure monitoring (RDC)<sup>OE</sup>



+ "---" or "--- ---" appears on the display.

Possible cause:

The vehicle has not yet accelerated past the threshold of approximately 30 km/h. The RDC sensors do not start transmitting signals until the motorcycle reaches a speed above this threshold (► 97).

- Increase speed above this threshold and observe the RDC readings. Assume that a permanent fault has not occurred unless the 'General' warning light comes on to accompany the symptoms. Under these circumstances:
- Have the fault rectified by a specialist workshop, preferably an authorised BMW Motorrad dealer.

Possible cause:

Wireless communication with the RDC sensors has been disrupted. Possible causes include radio-communication systems operating in the vicinity and interfering with the link between the RDC control unit and the sensors.

- Move to another location and observe the RDC readings. Assume that a permanent fault has not occurred unless the 'General' warning light comes

on to accompany the symptoms.

Under these circumstances:

- Have the fault rectified by a specialist workshop, preferably an authorised BMW Motorrad dealer.

### Fuel down to reserve



Warning light for fuel down to reserve shows.



**WARNING**

### Irregular engine operation or engine shutdown due to lack of fuel.

Risk of accident. Damage to catalytic converter.

- Do not run the fuel tank dry. ◀

Possible cause:

The fuel tank contains no more than the reserve quantity of fuel.



Reserve fuel

approx. 3 l

- Refuelling (►► 89).

## ABS self-diagnosis not completed



ABS telltale and warning light flashes.

Possible cause:

The ABS function is not available, because self-diagnosis did not complete. The motorcycle has to move forward a few metres for the wheel sensors to be tested.

- Pull away slowly. Bear in mind that the ABS function is not available until self-diagnosis has completed.

## ABS fault



ABS telltale and warning light shows.

Possible cause:

The ABS control unit has detected a fault.

- You can continue to ride. Bear in mind that the ABS function is not available. Bear in mind the more detailed information on certain situations that can lead to ABS fault messages (►► 95).
- Have the fault rectified as quickly as possible by a specialist workshop, preferably an authorised BMW Motorrad dealer.

## ASC intervention

– with Automatic Stability Control (ASC)<sup>OE</sup>



ASC telltale and warning light quick-flashes.

The ASC has detected a degree of instability at the rear wheel and has intervened to reduce torque. The warning light flashes for longer than ASC intervention lasts. This affords the rider visual feedback on control intervention even after the critical situation has been dealt with.

## ASC self-diagnosis not completed

– with Automatic Stability Control (ASC)<sup>OE</sup>



ASC telltale and warning light slow-flashes.

Possible cause:

Self-diagnosis did not complete, so the ASC function is not available. The engine must be running and the motorcycle must reach a speed of at least 5 km/h

in order for ASC self-diagnosis to complete.

- Pull away slowly. Bear in mind that the ASC function is not available until self-diagnosis has completed.

### ASC switched off

– with Automatic Stability Control (ASC)<sup>OE</sup>



ASC telltale and warning light shows.

Possible cause:

The rider has switched off the ASC system.

- Switch on ASC.

### ASC fault

– with Automatic Stability Control (ASC)<sup>OE</sup>



ASC telltale and warning light shows.

Possible cause:

The ASC control unit has detected a fault.

- You can continue to ride. Bear in mind that the ASC function is not available. Bear in mind the more detailed information on certain situations that can lead to ASC fault messages (►► 96).
- Have the fault rectified as quickly as possible by a specialist workshop, preferably an authorised BMW Motorrad dealer.

### On-board computer display

– with on-board computer<sup>OE</sup>



Distance travelled after fuel down to reserve (►► 41)



Average consumption



Average speed



Current consumption



Ambient temperature (►► 42)

### Fuel level

Due to the complex shape of the fuel tank, it is impossible to determine the fuel level when the tank is approaching capacity. For this reason, the fill-level indicator only displays the bottom half of the filling capacity in detail.

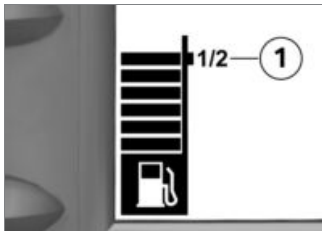

If the fill-level indicator reaches the 1/2-mark **1**, the fuel tank is half-full. From then on, the fill-level will be displayed more accurately.

The fuel warning light shows when the fuel level drops to reserve.

## Fuel reserve

The quantity of fuel in the fuel tank after the fuel warning light comes on is dependent on the driving dynamics: the more the fuel moves inside the tank (due to regularly changing heel angles, frequent braking and acceler-

ation), the more difficult it becomes to determine the reserve volume. However, the tank will at least contain the fuel reserve volume indicated on the back cover.

– with on-board computer<sup>OE</sup>



After the fuel warning light comes on, the distance that has travelled since this time is displayed.

The distance that can still be travelled using the reserve quantity depends on the style of riding (usage) and the amount of fuel remaining at the time the light came on (see explanation above). After a refuelling stop, the distance counter for reserve fuel is reset if the amount of fuel in the tank is greater than the reserve quantity.

## Service-due indicator



If the next service is due in less than one month, the date for the next service **1** is shown briefly after the Pre-Ride-Check completes. The month and year are displayed with two and four digits respectively, separated by a colon. In this example, the reading means "June 2014".



If the vehicle covers long distances in the course of the year, under certain circumstances it might be necessary to have it serviced at a date in advance of the forecast due date. If the countdown distance to the early service is less than 1000 km, the countdown distance **1** appears on the display in steps of 100 km. It is shown briefly after the Pre-Ride-Check completes.



If service is overdue, the due date or the odometer reading at which service was due is accompanied by the 'Gener-

al' warning light showing yellow. The word "Service" remains permanently visible.



## NOTICE

If the service-due indicator appears more than a month before the service date, the date saved in the instrument cluster must be adjusted. This situation can occur if the battery was disconnected for a prolonged period of time.

If you want to have the date set consult a specialist workshop, preferably an authorised BMW Motorrad dealer. ◀

## Ambient temperature

– with on-board computer<sup>OE</sup>



If the outside temperature drops below 3 °C the temperature display flashes to draw your attention to the risk of black ice forming. The display auto-

matically switches from any other mode to the temperature reading when the temperature drops below this threshold for the first time.

When the motorcycle is at a standstill the heat of the engine can falsify the ambient-temperature reading. If the effect of the engine's heat becomes excessive, "--" temporarily appears on the display.



## WARNING

**Risk of black ice forming at temperatures above 3 °C, even though no ambient-temperature warning is issued.**

Risk of accident due to icy surface.

- Always take extra care when temperatures are low; remember that there is particular danger of black ice

forming on bridges and where the road is in shade.◀

## Tyre pressure

– with tyre pressure monitoring (RDC)<sup>OE</sup>

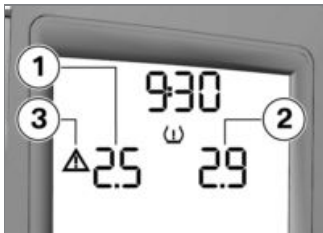

The front tyre pressure is on the left **1**; the reading on the right **2** is the rear tyre pressure. Immediately after the ignition is switched on "-- --" is displayed. The tyre-pressure values will only be transmitted after exceeding a speed of 30 km/h.

The tyre-pressure readings are based on a tyre air temperature of 20 °C.

 If warning triangle **3** also shows, the reading is a warning. The affected pressure flashes.

If the affected value is close to the limit of the permissible tolerance range, the 'General' warning light shows yellow. If the tyre pressure registered by the sensor is outside the permissible tolerance range, the 'General' warning light flashes red.

The detailed description of BMW Motorrad RDC starts on page (➡ 97).



## Operation

Ignition switch/steering lock .....	46	Brakes .....	60
Electronic immobiliser .....	47	Mirrors .....	61
Clock .....	47	Spring preload .....	61
Reading.....	48	Damping.....	62
Stopwatch .....	50	Electronic Suspension Adjustment (ESA) .....	63
Lights.....	51	Tyres .....	64
Turn indicators.....	52	Headlight .....	64
Hazard warning flashers.....	53	Seat .....	65
Light signals .....	53	Helmet holder .....	67
Sound signals.....	55		
Emergency off switch (kill switch).....	57		
Heated handlebar grips .....	57		
BMW Motorrad ASC.....	58		
Clutch .....	59		

## Ignition switch/steering lock

### Keys

You receive two ignition keys and one emergency key. The emergency key is small and light so that it can always be kept in a wallet or purse, for example. It can be used when no ignition key is available. It is not intended for constant use.

Please consult the information on the electronic immobiliser (EWS) (► 47) if a key is lost or misplaced. Ignition switch/steering lock, fuel filler cap lock and seat lock are all operated with the same key.

- with cases<sup>OE</sup>
- with topcase<sup>OA</sup>

If you wish you can arrange to have the cases and the topcase fitted with locks that can be opened with this key as well. Consult a specialist workshop,

preferably an authorised BMW Motorrad dealer.

### Switching on ignition



- Insert the key in the ignition switch and turn to position **1**.
  - » Side lights and all function circuits are switched on.
  - » Pre-ride check is performed (► 83)
  - » ABS self-diagnosis is in progress. (► 84)
- with Automatic Stability Control (ASC)<sup>OE</sup>
  - » ASC self-diagnosis is in progress. (► 84)◁

### Switching off ignition

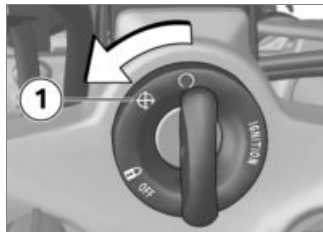

- Turn the key to position **1**.
  - » Lights switched off.
  - » Handlebars not locked.
  - » Key can be removed.
  - » Electrically powered accessories remain operational for a limited period of time.
  - » The battery can be recharged via the socket.

### Lock the handlebars

- Turn the handlebars all the way to the left.



- Turn the key to position **1**, while moving the handlebars slightly.
- » Ignition, lights and all function circuits are switched off.
- » Handlebars are locked.
- » Key can be removed.

## Electronic immobiliser

The electronic design of the motorcycle allows it to access data stored in the ignition key by means of a ring antenna located in the ignition switch. The engine control unit will only allow the en-

gine to be started if the key is identified as “authorised”.

### NOTICE

A spare key attached to the same ring as the ignition key used to start the engine could “irritate” the electronics, in which case the enabling signal for starting is not issued. The EWS warning appears in the multifunction display.

Always keep the spare key separately from the ignition key. ◀

If you lose a key, you can have it barred by your authorised BMW Motorrad dealer. If you wish to do this, you will need to bring all other keys for the motorcycle with you.

The engine cannot be started by a barred key, but a key that has been barred can subsequently be reactivated.

You can obtain emergency/extra keys only through an authorised BMW Motorrad dealer. The keys are part of an integrated security system, so the dealer is under an obligation to check the legitimacy of all applications for replacement/extra keys.

## Clock

### Setting clock

#### WARNING

### Adjusting the clock while riding.

Risk of accident

- Set the clock only when the motorcycle is stationary. ◀
- Switch on the ignition.

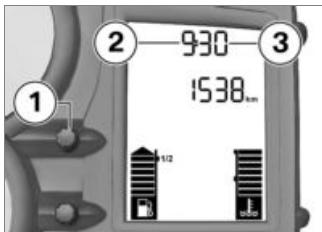

- Press and hold down button **1** until the hours number **2** flashes.
- Repeatedly press button **1** until the hours number is correct.
- Press and hold down button **1** until the minutes number **3** flashes.
- Repeatedly press button **1** until the minutes number is correct.

## Reading

### Selecting readings

- Switch on the ignition.

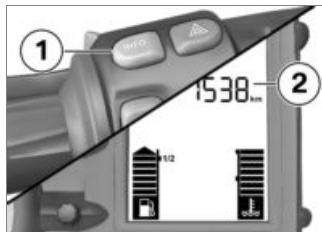

- Press button **1** to select the reading in values area **2**. The following values can be displayed:
  - Total distance travelled (shown here)
  - Tripmeter 1 (Trip I)
  - Tripmeter 2 (Trip II)
  - Warnings, if applicable
  - with tyre pressure monitoring (RDC)<sup>OE</sup>
  - Tyre pressures <

– with on-board computer<sup>OE</sup>

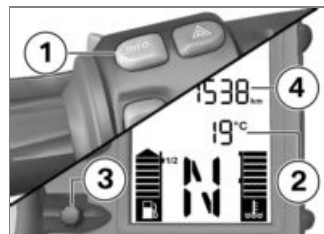

- Press button **1** to select the reading in values area **2**. The following values can be displayed:
  - Ambient temperature
  - Average speed
  - Average consumption
  - Current consumption



Distance travelled since fuel down to reserve

- Press button **3** to select the reading in values area **4**.
- The following values can be displayed:
- Total distance travelled (shown here)
  - Tripmeter 1 (Trip I)
  - Tripmeter 2 (Trip II)
  - Warnings, if applicable

– with tyre pressure monitoring (RDC)<sup>OE</sup>

Tyre pressures<<

## Resetting tripmeter

- Switch on the ignition.
- Select a tripmeter.

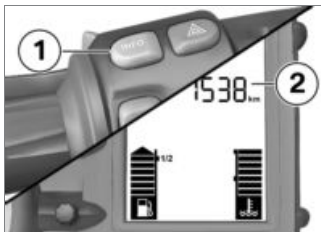

- Press and hold down button **1** until tripmeter **2** reading is reset.

– with on-board computer<sup>OE</sup>

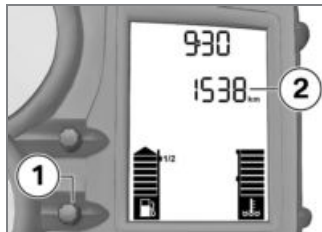

- Press and hold down button **1** until tripmeter **2** reading is reset.<

## Resetting the average values

– with on-board computer<sup>OE</sup>

- Switch on the ignition.
- Select average consumption or average speed.



- Press and hold down button **1** until the value shown is reset.

## Stopwatch

- with on-board computer<sup>OE</sup>

### Stopwatch

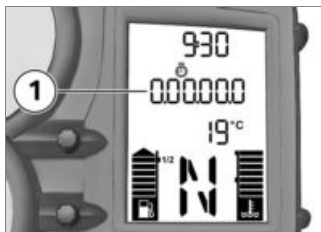

You can switch from the odometer reading to a stopwatch **1**. The readout is in hours, minutes, seconds and tenths of a second, with dots as separators. The stopwatch continues to time in the background if you switch back temporarily to the odometer reading. Similarly, the stopwatch continues timing if you temporarily switch off the ignition.

### Operate stopwatch

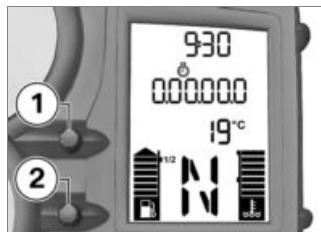

- If necessary, use button **1** to switch from the odometer to the stopwatch.
- When the stopwatch is stopped, press button **2** to start timing with the stopwatch.
- When the stopwatch is running, press button **2** to stop timing with the stopwatch.
- Press and hold down button **2** to reset the stopwatch.

## Lap timer

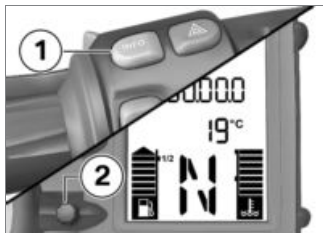

By swapping the functions of button **1** on the handlebar fitting and the functions of button **2**, you can make the stopwatch easier to use (as a lap timer) as you ride. If you swap the functions in this way the stopwatch and the odometer are operated by means of button **1** and you must use button **2** to operate the on-board computer.

## Changing button functions

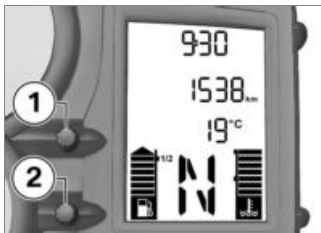

- Press button **1** and button **2** at the same time and hold them down until the reading changes.
  - » FLASH (redline warning) appears, along with ON or OFF.
- Press button **2**.
  - » LAP (Lap-Timer) and ON or OFF appear.
- Repeatedly press button **1** until the reading shows the mode you want.

- » ON: Stopwatch operated by means of the INFO button on the handlebar fitting.
- » OFF: Stopwatch operated by means of button **2** in the instrument panel.
- To save the setting, press button **1** and button **2** at the same time and hold them down until the reading changes.

## Lights

### Side light

The side lights switch on automatically when the ignition is switched on.



### NOTICE

The side lights place a strain on the battery. Do not switch the ignition on for longer than absolutely necessary. ◀

## Low-beam headlight

The low-beam headlight switches on automatically when you start the engine.

## High-beam headlight and headlight flasher

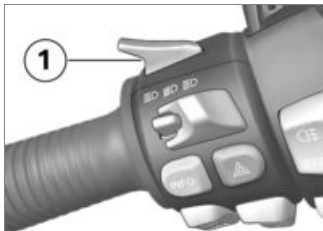

- Push switch **1** forward to switch on the high-beam headlight.
- Pull switch **1** back to operate the headlight flasher.

## Parking light

- Switch off the ignition.



- Immediately after switching off the ignition, push button **1** to the left and hold it in this position until the parking lights come on.
- Switch the ignition on and off again to switch off the parking lights.

## Turn indicators

### Operating the turn indicators

- Switch on the ignition.



- Push button **1** to the left to switch on the left turn indicators.
- Push button **1** to the right to switch on the right turn indicators.
- Press button **1** to switch off the flashing turn indicators.



## NOTICE

The turn indicators are cancelled automatically after the defined time and distance. The defined time and distance can be set by an authorised BMW Motorrad dealer. ◀

## Hazard warning flashers

### Operating hazard warning flashers

- Switch on the ignition.

#### NOTICE

The hazard warning flashers place a strain on the battery. Do not use the hazard warning flashers for longer than absolutely necessary. ◀

#### NOTICE

If you press a turn-indicator button with the hazard warning flashers switched on, the turn-indicator function is activated instead of the hazard warning flashers, and remains active until you release the button. The hazard warning flashers recommence flashing as soon as the button is released. ◀



- Press button **1** to switch on the hazard warning flashers.
  - » Ignition can be switched off.
- Press button **1** again to switch off the hazard warning flashers.

## Light signals

### Operating front LED marker strobes

– with LED marker strobe<sup>OE</sup>



- Switch on the ignition.

#### NOTICE

The front LED marker strobes place a load on the second battery. Switch on LED marker strobes for a limited time period only. ◀

- Press bottom section of switch **1** to turn on the front LED marker strobes.
  - » How to interpret the status-indicator light:
    - Blue status-indicator light on: LED marker strobe lights are on

- Blue status-indicator light flashing: LED marker strobe lights faulty
- Centre the switch to switch the front LED marker strobe lights off.

### Operating rear marker light / 360° marker strobe

- with LED 360° marker strobe<sup>OE</sup>



- Switch on the ignition.

### NOTICE

The 360° marker strobe places a load on the second battery.

Switch on 360° marker strobe for a limited time period only. ◀

### WARNING

#### Riding with the 360° marker light extended.

Risk of accident

- Do not ride the motorcycle with the pole of the 360° marker light extended. ◀
- Press bottom section of switch **1** to switch on the 360° marker light or the rear marker lights.
  - » How to interpret the status-indicator light:
    - Blue status-indicator light ON: 360° marker strobe light is switched on
    - Blue status-indicator light flashing: 360° marker strobe light is defective
- Centre the switch to switch the 360° marker strobe light off.

### Operating "STOP" signal

- with STOP signal<sup>OE</sup>

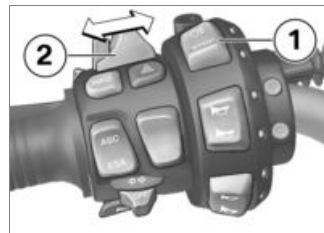

- Press bottom section of switch **1** to switch on the STOP signal.
  - » How to interpret the indicator light:
    - Red indicator light flashes in rhythm with the display text.
- If the STOP signal switch **2** is switched on in order to change between 2 display texts, e.g. "PLEASE FOLLOW" or "STOP POLICE".

## NOTICE

The displayed text is country-specific and may vary.◀

## NOTICE

Using a programming unit available from BMW Motorrad it is possible to set different stop texts. The programming unit and the replacement parts are available from your authorised BMW Motorrad dealer.◀

- Centre switch **1** in order to switch the STOP signal off.

## Activating lights-off setting

– with lights-off setting<sup>OE</sup>

## WARNING

**Insufficient visibility for other road users.**

Risk of accident

- Exercise caution when using the "lights off" function.
- Comply with the statutory regulations.◀



- Press top section of switch **1** to activate the lights-off setting.
  - » Dipped beam, side lights and tail light are switched off.
  - » How to interpret the status-indicator light:
    - Green status-indicator light ON: Lights-off setting is active
- Centre the switch to deactivate the lights-off setting.

## Sound signals

### Operating hailing system

– with electronic hailing system<sup>OE</sup>



- Press top section of switch **1** to set the hailing system to standby mode.
  - » The hailing system sounds one complete hailing cycle when horn button **2** is pressed.
- Press bottom section of switch **1** to activate the hailing system in constant-operation mode.

- Centre the switch **1** to switch the hailing system off.

### NOTICE

The "hailing system" function is not available unless the marker light has been activated.◀



- Press switch **1** to select the type of hailing-system signal, for example day and night signal or city and countryside signal.

### NOTICE

Different countries use different hailing-system signals, so the signal can vary.◀

### NOTICE

There is a choice of tone sequences and siren sounds for different countries. The programming unit and the replacement parts are available from your authorised BMW Motorrad dealer.◀

### Operating siren

– with siren, electronic<sup>OE</sup>



- Press top section of switch **1** to activate the siren in yelp mode.
- Press bottom section of switch **1** to activate the siren in wail mode.
- When the siren is active, press the horn button **2** to toggle from one siren operating mode to the next.
- Centre the switch **1** to switch the siren off.



## Emergency off switch (kill switch)



1 Emergency off switch (kill switch)



### WARNING

#### Operation of the kill switch while riding.

Risk of fall due to rear wheel locking.

- Do not operate the kill switch when riding. ◀

The emergency off switch is a kill switch for switching off the engine quickly and easily.

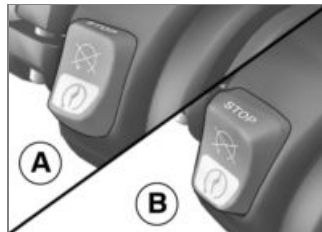

- A Engine switched off  
B Normal operating position (run)

## Heated handlebar grips

– with heated handlebar grips<sup>OE</sup>

### Operate the heated handlebar grips

- Start the engine.

 **NOTICE**

The heating in the heated handlebar grips can be activated only when the engine is running.◀

 **NOTICE**

The increase in power consumption caused by having the heated handlebar grips switched on can drain the battery if you are riding at low engine speeds. If the charge level is low, the heated handlebar grips are switched off to ensure the battery's starting capability.◀

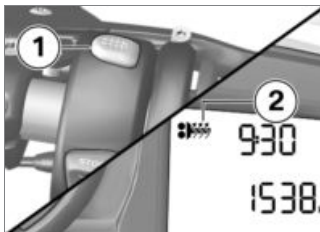

- Repeatedly press button **1** until the desired heating stage **2** appears on the display.

The handlebar grips have two-stage heating. Stage two is for heating the grips quickly: it is advisable to switch back to stage one as soon as the grips are warm.



50 % heating power



100 % heating power

» The selected heating stage will be saved if you allow a certain

length of time to pass without making further changes.

- In order to switch off the heated handlebar grips, repeatedly press button **1** until the heated handlebar grip symbol **2** is no longer shown on the display.

## BMW Motorrad ASC

– with Automatic Stability Control (ASC)<sup>OE</sup>

### Switching off the ASC function

- Switch on the ignition.

 **NOTICE**

You have the option of deactivating the ASC function while the motorcycle is on the move.◀



## Switching on the ASC function



- Press and hold down button **1** until the ASC warning light changes status.

 ASC telltale and warning light shows.

- Release button **1** within two seconds.

 ASC telltale and warning light remains on.

» ASC function is switched off.

- Press and hold down button **1** until the ASC warning light changes status.

 ASC telltale and warning light goes out; if self-diagnosis has not completed it starts flashing.

- Release button **1** within two seconds.

 ASC telltale and warning light remains off or continues to flash.

» ASC function is switched on.

- You also have the option of switching the ignition off and then on again.



### NOTICE

An ASC fault has occurred if the ASC warning light shows when the motorcycle accelerates to a speed in excess of 5 km/h after the ignition was switched off and then on again. ◀

## Clutch

### Adjust the clutch lever



### WARNING

#### Adjusting the clutch lever while riding.

Risk of accident

- Do not attempt to adjust the clutch lever unless the motorcycle is at a standstill. ◀



- Turn adjusting screw **1** clockwise to increase the span between the clutch lever and the handlebar grip.
- Turn adjusting screw **1** counter-clockwise to reduce the span between the clutch lever and the handlebar grip.

**NOTICE**

The adjusting screw is easier to turn if you push the clutch lever forward.◀

**Brakes****Adjust the handbrake lever****WARNING****Changed position of the brake fluid reservoir.**

Air in the brake system.

- Do not turn the handlebars or the handlebar fitting on the handlebar.◀

**WARNING****Adjusting the brake lever while riding.**

Risk of accident

- Do not attempt to adjust the brake lever unless the motorcycle is at a standstill.◀

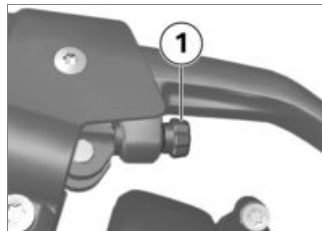

- Turn adjusting screw **1** clockwise to increase the span between the brake lever and the handlebar grip.
- Turn adjusting screw **1** counter-clockwise to reduce the span between the brake lever and the handlebar grip.

**NOTICE**

The adjusting screw is easier to turn if you push the brake lever forward.◀

## Mirrors

### Adjusting mirrors



- Adjust the mirror to the desired position by turning the housing and the mirror arm.

### Spring preload Setting

It is essential to set spring preload of the rear suspension to suit the load carried by the motorcycle. Increase spring preload when the motorcycle is heavily loaded and reduce spring preload

accordingly when the motorcycle is lightly loaded.

### Adjust spring preload for rear wheel

- Removing seat (→ 65).

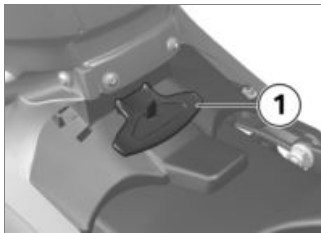

- Remove on-board toolkit 1.



### WARNING

#### Spring preload setting and spring-strut damping setting not matched.

Impaired handling.

- Adjust spring-strut damping to suit spring preload.◀
- If you want to increase spring preload, use the tool from the on-board toolkit to turn knob 1 clockwise.
- If you want to reduce spring preload, use the tool from the on-board toolkit to turn knob 1 counter-clockwise.



Basic setting of spring preload, rear

Turn the adjuster as far as it will go counter-clockwise (One-up without luggage)

Turn the adjuster as far as it will go counter-clockwise, then back it off 12 turns in the clockwise direction. (One-up with luggage)

Turn the adjuster as far as it will go counter-clockwise, then back it off 18 turns in the clockwise direction. (One-up with luggage and topcase)

Turn the adjuster as far as it will go clockwise (Two-up with luggage and topcase)

- Stow the on-board toolkit in its correct position.
- Install the seat (➡ 66).

## Damping Setting

Damping must be adapted to suit the condition of the surface on which the motorcycle is ridden and to suit spring preload.

- An uneven surface requires softer damping than a smooth surface.
- An increase in spring preload requires firmer damping, a reduction in spring preload requires softer damping.

### Adjust the damping for rear wheel

- Make sure the ground is level and firm and place the motorcycle on its stand.



- If you want to increase damping, turn adjusting screw **1** clockwise.
- If you want to reduce damping, turn adjusting screw **1** counter-clockwise.



Basic setting of rear-suspension damping characteristic

– without Electronic Suspension Adjustment (ESA)<sup>OE</sup>



Basic setting of rear-suspension damping characteristic

Turn the adjusting screw as far as it will go in the clockwise direction and then back it off one and a half turns (One-up without luggage)

Turn the adjusting screw as far as it will go in the clockwise direction and then back it off half a turn (One-up with luggage/two-up with luggage)◀

## Electronic Suspension Adjustment (ESA)

– with Electronic Suspension Adjustment (ESA)<sup>OE</sup>

### Possible settings

With the help of Electronic Suspension Adjustment ESA, you can calibrate the rear-wheel damping to the terrain with ease.

### Calling up settings

- Switch on the ignition.



- Press button **1** to view the current setting.



The currently selected damping is shown on the multifunction display at **1**. The meanings of the readings are as follows:

- COMF: Comfortable damping characteristic
- NORM: Normal damping characteristic
- SPORT: Sporty damping characteristic

» The setting shows briefly, then disappears automatically.

### Adjusting the chassis and suspension

- Switch on the ignition.



- Press button **1** to view the current setting.

To make different adjustment to the damping:

- Repeatedly press button **1** until the setting you want to use appears on the multifunction display.



### NOTICE

You can adjust the damping characteristic while the motorcycle is on the move.◀

- » The setting shown on the display is automatically accepted as the damping

characteristic if you allow a certain length of time to pass without pressing button **1**.

- » The ESA indicator disappears from the display as soon as adjustment completes.

## Tyres

### Checking tyre pressure



### WARNING

#### Incorrect tyre pressure.

Impairment of the motorcycle's handling characteristics. Shorter useful tyre life.

- Always check that the tyre pressures are correct.◀
- Make sure the ground is level and firm and place the motorcycle on its stand.
- Check tyre pressures against the data below.



Tyre pressure, front

2.5 bar (tyre cold)



Tyre pressure, rear

2.9 bar (tyre cold)

If tyre pressure is incorrect:

- Correct tyre pressure.

## Headlight

### Adjusting headlight for driving on left/driving on right

If the motorcycle is ridden in a country where the opposite rule of the road applies, its asymmetric low-beam headlight will tend to dazzle oncoming traffic.

Have the headlight set accordingly by a specialist workshop, preferably an

authorised BMW Motorrad dealer.

### **ATTENTION**

#### **Use of ordinary commercially available adhesive tape.**

Damage to the plastic lens of the light.

- Consult a specialist workshop, preferably an authorised BMW Motorrad dealer, in order to avoid damaging the plastic lens of the light. ◀

#### **Headlight beam throw and spring preload**

Headlight beam throw is generally kept constant when spring preload is adjusted to suit load. However, a spring preload adjustment might not suffice if the motorcycle is very heavily loaded. Under these circumstances, headlight beam throw

has to be adjusted to suit the weight carried by the motorcycle.

### **NOTICE**

If there are doubts about the correct headlight beam throw, have the setting checked by a specialist workshop, preferably an authorised BMW Motorrad dealer. ◀

#### **Adjusting headlight beam throw**



- 1** Headlight beam-throw adjustment

The headlight beam-throw is adjusted via an engage pivot lever.

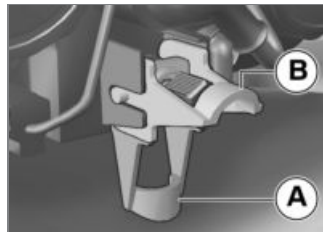

- A** Position for heavy load
- B** Neutral position

#### **Seat**

##### **Removing seat**

- Make sure the ground is level and firm and place the motorcycle on its stand.

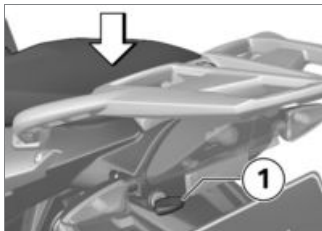

- Turn the key to the left in seat lock **1** and hold it in this position while pressing down the rear part of the seat.
- Lift the seat at the rear and release the key.
- Remove the seat and place it, upholstered side down, on a clean surface.

## Installing the seat

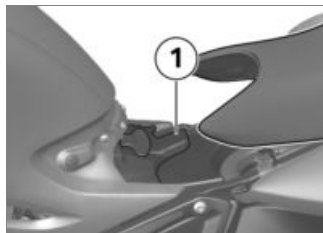

- Position the seat in holder **1** and apply firm downward pressure to the rear of the seat.  
» The seat engages with an audible click.

## Removing seat with optional extras

- with single seat with two-way radio box<sup>OE</sup>
- Make sure the ground is level and firm and place the motorcycle on its stand.

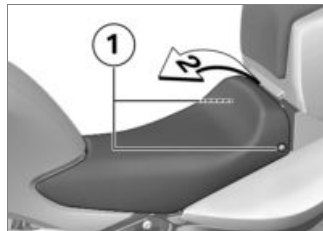

- Remove screws **1**.
- Lift seat **2** at rear.
- Remove the seat and place it, upholstered side down, on a clean surface.

## Installing seat with optional extras

- with single seat with two-way radio box<sup>OE</sup>

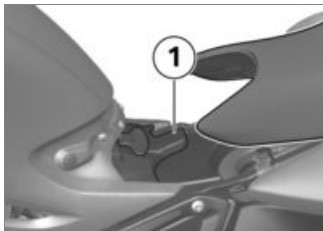

- Engage the seat in holder **1**.

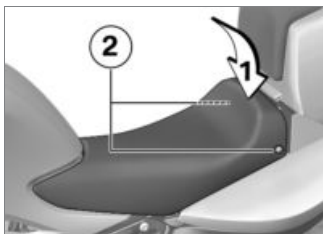

- Press down on the seat **1** at the rear.
- Install screws **2**.

## Helmet holder

### Secure the helmet to motorcycle

- Removing seat (➡ 65).

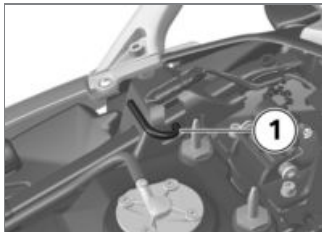

- Use a plastic-sheathed steel cable to secure the helmet to helmet holder **1**.



### ATTENTION

#### Incorrect positioning of the helmet lock.

Scratch marks on trim panel.

- Make sure the lock is out of the way when you hook the helmet into position. ◀
- Position the helmet as shown in the illustration.
- Install the seat (➡ 66).



## **Anti-theft alarm DWA**

Overview .....	70
Activation .....	70
Alarm function .....	72
Deactivation .....	73
Programming .....	74
Registration of the remote control .....	76
Synchronising.....	77
Battery.....	78

## Overview

– with alarm system (DWA)<sup>OE</sup>

### General information about the anti-theft alarm (DWA)

Any attempt to move the vehicle, change its position, start it without an authorised key or disconnect the starter battery will trigger the alarm. The sensitivity of the system is parameterised so that slight vibrations will not trigger the alarm. Once the system has been activated, any attempt to tamper with the vehicle is indicated acoustically by the siren and visually by all four turn indicators flashing in unison.

You can change some of your DWA alarm system's parameters to suit your personal preferences.

### Conserving power in the vehicle's starter battery

In order to conserve the power of the starter battery and ensure that the vehicle will start, the DWA anti-theft alarm automatically switches off the alarm function a few days after being activated. In most cases, however, the system will remain active for at least 10 days.

### Radio interference

Radio systems or devices transmitting on the same frequency as the remote control of the DWA anti-theft alarm can interfere with operation of the system. If problems of this nature occur, point the remote control toward the vehicle from another direction.

## Controls

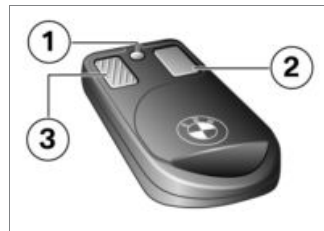

- 1 LED
- 2 Right button (▣ 72)
- 3 Left button (ribbed) (▣ 71)

## Activation

– with alarm system (DWA)<sup>OE</sup>

## Activation with motion sensor



The alarm function is activated

- by pressing button **1** on the remote control once, or
- by switching off the ignition (if programmed); when the ignition is switched off 30 seconds elapse before the start of the activation phase.

Activation is confirmed

- by the turn indicators flashing twice and
- by the alarm tone sounding twice.

If you want to activate the alarm function more than one minute after switching off the ignition, you must press button **1** for longer than one second.

### Activation phase

The anti-theft alarm needs 15 seconds to achieve fully active status. No alarm is triggered during this time.

## Conserving battery power in the control unit (anti-theft alarm activated)



If you want to activate the alarm function more than one minute after switching off the ignition, you must press button **1** for longer than one second. If it remains deactivated for approximately one hour, the anti-theft alarm shuts down in order not to draw power unnecessarily from the battery. If you want to activate the alarm function after the anti-theft alarm has shut down in

this way, you have to switch the ignition on and then off again.

### Motion sensor when motorcycle is to be transported

If you want to transport your motorcycle by train or on a trailer, for example, it is advisable to switch off the motion sensor. If the motion sensor is not switched off the severe movements occurring in transit could trigger the alarm.

### Deactivating motion sensor



- Press button **1** on the remote control a second time during the activation phase.
  - » Turn indicators flash three times.
  - » Alarm tone sounds three times.
  - » Motion sensor is deactivated.

### Alarm function

- with alarm system (DWA)<sup>OE</sup>

### Alarm triggers

An alarm can be triggered by:

- the motion sensor
- attempt to switch on the ignition with an unauthorised key
- disconnection of the anti-theft alarm (DWA) from the vehicle's battery (DWA internal battery in the anti-theft alarm provides power).

### Alarm



An alarm lasts for 26 seconds. The system is active again another 12 seconds later. You can interrupt an alarm at any time by pressing button **1** on the remote

control. This function does not change the status of the anti-theft alarm.

While an alarm is in progress an alarm tone sounds and the turn indicators flash. You can program the type of alarm tone.

### Reason for an alarm

Once you have deactivated the alarm function, the anti-theft alarm LED is active for a period of one minute to show you reasons for alarms, if any, that were triggered in your absence:

- Flashes 1x: Motion sensor; motorcycle was rocked forward/back
- Flashes 2x: Motion sensor; motorcycle was rocked to the side
- Flashes 3x: Ignition switched on with unauthorised key
- Flashes 4x: Disconnection of the anti-theft alarm from the vehicle's battery

### Information on alarm triggering

If an alarm was triggered after the last activation of the alarm function, the rider is notified accordingly by an alarm tone sounding once when the ignition is switched on.

### Deactivation

– with alarm system (DWA)<sup>OE</sup>

### Deactivating alarm function



- Press button **1** on the remote control once **or** switch on the ignition with an authorised key.



#### NOTICE

Note that you can deactivate the alarm function with the ignition key only when the kill switch is in the RUN position. ◀



#### NOTICE

If the alarm function is deactivated by the remote control and

the ignition is not subsequently switched on, the alarm function automatically goes active again after 30 seconds if "Activation after ignition OFF" is programmed. ◀

- » Turn indicators flash once.
- » Alarm tone sounds once (if programmed).
- » Alarm function is deactivated.

### Conserving battery power (anti-theft alarm deactivated)

Approximately one hour after the alarm is armed, the receiver for the remote control in the anti-theft alarm shuts down in order not to draw power unnecessarily from the battery. If you want to deactivate the alarm function after the receiver has shut down in this way, you have to switch the ignition on.

## Programming

- with alarm system (DWA)<sup>OE</sup>

### Programming options

You can customise the following parameters of your anti-theft alarm:

- Confirmation alarm tone after activation/deactivation of the anti-theft alarm in addition to visual confirmation by turn indicators flashing
- Rising and falling or intermittent alarm tone
- Automatic activation of the alarm function after the ignition is switched off

### Default settings

- The anti-theft alarm ships with the following default settings:
- Confirmation alarm tone after activation/deactivation of the anti-theft alarm: No
  - Alarm tone: Intermittent

- Automatic activation of the alarm function after the ignition is switched off: No

## Programming anti-theft alarm



- Deactivate the alarm function.
- Switch on the ignition.
- Press button **1** three times.
  - » Acknowledgement tone sounds once.
- Within ten seconds, switch off the ignition.
- Press button **2** three times.
  - » Acknowledgement tone sounds once.

- Within ten seconds, switch on the ignition.
- » Acknowledgement tone sounds three times.
- » The programming function is active.

Programming is a four-step process, although no function is allocated to step 2. The number of times the anti-theft alarm LED on the vehicle flashes corresponds to the active programming step. An alarm tone sounds by way of confirmation when button **1** is pressed, and an acknowledgement tone sounds when button **2** is pressed.

- **Step 1:** Do you want a confirmation tone to sound after activation/deactivation of the anti-theft alarm?

Yes:

- Press button **1**.

No:

- Press button **2**.

- **Step 2:**

No function allocated to this step.

- Press button **1** or button **2**.

- **Step 3:** Which alarm tone would you like the alarm to sound?

Rising and falling:

- Press button **1**.

intermittent:

- Press button **2**.

- **Step 4:** Do you want to have the alarm function activated automatically when you switch off the ignition?

Yes:

- Press button **1**.

No:

- Press button **2**.

## Under what circumstances is programming aborted?

There are two ways in which programming can be cancelled:

- if the ignition is switched off before completion of the last step in the programming sequence.
- automatically if more than 30 seconds are allowed to elapse between any two consecutive steps in the programming routine.

The new settings are not saved if programming is aborted.

## Saving programming

There are two ways in which programming can be saved:

- if the ignition is switched off after completion of the last step in the programming sequence

– automatically 30 seconds after completion of the last step in the programming routine

The anti-theft alarm LED goes out and four acknowledgement tones sound.

## Registration of the remote control

– with alarm system (DWA)<sup>OE</sup>

### When is it necessary to register a remote control?

If you want to register an additional remote control or register a remote control as a replacement for one that has been mislaid, you must always register all the remote control units with the anti-theft alarm. You can register a maximum of four remote control units.

## Registering remote control



- Deactivate the alarm function.
- Switch on the ignition.
- Press button **2** three times.
  - » Acknowledgement tone sounds once.
- Within ten seconds, switch off the ignition.
- Press button **2** three times.
  - » Acknowledgement tone sounds once.
- Within ten seconds, switch on the ignition.

» Acknowledgement tone sounds twice.

You can now register a maximum of four remote control units with the anti-theft alarm. Registration is a three-step process and has to be repeated for each remote control unit.

- Press and hold down button **1** and button **2**.
  - » LED flashes for ten seconds.
- As soon as the LED goes out, release button **1** and button **2**.
  - » LED lights up.
- Press button **1** or button **2**.
  - » Alarm tone sounds once.
  - » LED goes out.
  - » Remote control has been registered.
- Repeat this three-step procedure for each additional remote control.

## Termination of registration

Registration is terminated in the following situations:

- 4 remote control units have been logged on.
- Ignition is switched OFF.
- 30 seconds elapse without a button being pressed after the ignition has been switched off.
- 30 seconds elapse without a button being pressed after a remote control unit has been registered.

When registration terminates the LED flashes and the acknowledgement tone sounds three times.

## Synchronising

- with alarm system (DWA)<sup>OE</sup>

## When is it necessary to synchronise the remote control?

The remote control has to be synchronised if the buttons of the remote control have been pressed more than 256 times outside the receiver's range. Once this limit has been reached, the receiver on the vehicle will no longer react to the signals from the remote control.

## Synchronising remote control



- Press and hold down button **1** and button **2**.
    - » LED flashes for ten seconds.
  - As soon as the LED goes out, release button **1** and button **2**.
    - » LED lights up.
  - Press button **1** or button **2**.
    - » LED goes out.
- Remote control has been synchronised.

## Battery

– with alarm system (DWA)<sup>OE</sup>

### When does the battery have to be changed?

The batteries in the remote control are due to be changed after approximately 2-3 years. You can tell that the battery is weak if the LED does not light up or lights up only briefly when a button is pressed.

### Changing battery

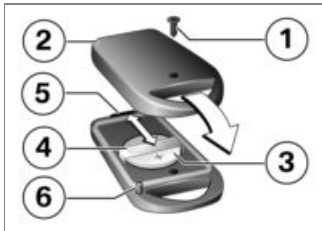

- Remove screw **1** and remove bottom part of housing **2**.

- Slide old battery **3** forward from under retainer **4**.



### ATTENTION

#### Batteries unsuitable or not inserted in compliance with correct procedure.

Component damage

- Use only the specified type of battery (see "Technical Data").
- When inserting the battery, always make sure polarity is correct. ◀
- Slip the new battery into position, making sure that the positive terminal of the battery is facing up.
- Position the bottom part of the housing at projection **5** of the front edge and close the housing, noting two guide pins **6**.
- Install the screw.
- » The LED on the remote control lights up, indicating that the

remote control has to be activated.

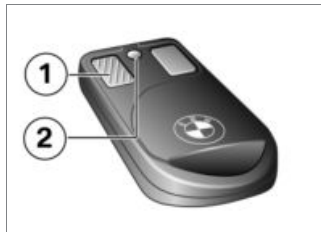

- To activate the remote control, make sure that it is within range of the receiver and press button **1** twice.
  - » LED **2** starts flashing and then goes out after a few seconds.
  - » The remote control is again ready for use.

## **Riding**

Safety instructions .....	80
Comply with checklist.....	82
Starting .....	82
Twistgrip brake .....	85
Running in .....	86
Redline warning.....	86
Brakes .....	87
Parking your motorcycle .....	88
Refuelling .....	89
Fuel grade .....	91
Securing motorcycle for transportation .....	91

## Safety instructions

### Rider's equipment

The following clothing will protect you for every journey:

- Helmet
- Motorcycling jacket and trousers
- Gloves
- Boots

This applies even to short journeys, and to every season of the year. Your authorised BMW Motorrad dealer will be glad to advise you on the correct clothing for every purpose.

### Loading



#### WARNING

**Handling adversely affected by overloading and imbalanced loads.**

Risk of falling

- Do not exceed the permissible gross weight and be sure to comply with the instructions on loading.◀
- Adjusting spring preload setting and damping to the total weight.
  - with cases<sup>OA</sup>
- Ensure that the case volumes on the left and right are equal.
- Make sure that the weight is uniformly distributed between right and left.
- Pack heavy items at the bottom of the cases and toward the inboard side.
- Note the maximum permissible payload and the speed limit for riding with cases fitted, as stated on the label inside the case (see also the section entitled "Accessories").◀
- with topcase<sup>OA</sup>
- Note the maximum permissible payload and the speed limit

for riding with topcase fitted, as stated on the label inside the case (see also the section entitled "Accessories").◀

- with tank rucksack<sup>OA</sup>
- Note the maximum permissible payload of the tank rucksack.



Payload of tank bag

max 5 kg◀

- Note the maximum permissible payload of the luggage carrier.



Payload of luggage carrier

max 10 kg

### Speed

If you ride at high speed, always bear in mind that various boundary conditions can adversely affect the handling of your motorcycle, e.g.:

- Spring-strut and shock-absorber system not set up correctly
- Imbalanced load
- Loose clothing
- Insufficient tyre pressure
- Poor tyre tread
- Added luggage systems such as cases, topcase and tank rucksack. Observe the speed limit indicated on the label in the respective luggage system.

### Risk of poisoning

Exhaust fumes contain carbon monoxide, which is colourless and odourless but highly toxic.

#### WARNING

#### **Exhaust gases adversely affecting health.**

Risk of asphyxiation

- Do not inhale exhaust fumes.
- Do not run the engine in an enclosed space.◀

### Risk of burn injury

#### CAUTION

#### **Engine and exhaust system become very hot when the vehicle is in use.**

Risk of burn injury

- When you park the vehicle make sure that no-one and no objects can come into contact with the hot engine and exhaust system.◀

### Catalytic converter

If misfiring causes unburned fuel to enter the catalytic converter, there is a danger of overheating and damage.

The following guidelines must be observed:

- Do not run the fuel tank dry
- Do not attempt to start or run the engine with a spark-plug cap disconnected

- Stop the engine immediately if it misfires
- Use only unleaded fuel
- Comply with all specified maintenance intervals.

#### ATTENTION

#### **Unburned fuel in catalytic converter.**

Damage to catalytic converter.

- Note the points listed for protection of the catalytic converter.◀

### Risk of overheating

#### ATTENTION

#### **Engine running for prolonged period with vehicle at stand-still.**

Overheating due to insufficient cooling. In extreme cases, the motorcycle could catch fire.

- Do not allow the engine to idle unnecessarily.
- Ride away immediately after starting the engine.◀

## Tampering



### ATTENTION

#### **Tampering with the motorcycle (e.g. engine management ECU, throttle valves, clutch).**

Damage to the affected parts, failure of safety-relevant functions. Damage due to tampering is not covered by the warranty.

- Do not tamper with the vehicle in any way that could result in tuned performance.◀

## Comply with checklist

- At regular intervals, use the checklist below to check your motorcycle.

### **Always before riding off:**

- Operation of the brake system
- Operation of the lights and signalling equipment
- Checking clutch function (▣▣▣▣ 107).
- Check the tyre tread depth (▣▣▣▣ 108).
- Cases correctly installed and luggage secured

### **Every 3rd refuelling stop:**

- without Electronic Suspension Adjustment (ESA)<sup>OE</sup>
- Adjust spring preload for rear wheel (▣▣▣▣ 61).◀
- without Electronic Suspension Adjustment (ESA)<sup>OE</sup>
- Adjust the damping for rear wheel (▣▣▣▣ 62).◀
- with Electronic Suspension Adjustment (ESA)<sup>OE</sup>
- Adjust the chassis and suspension (▣▣▣▣ 63).◀

- Check engine oil level (▣▣▣▣ 101).
- Checking front brake pad thickness (▣▣▣▣ 103).
- Checking rear brake pad thickness (▣▣▣▣ 103).
- Check brake-fluid level, front brakes (▣▣▣▣ 104).
- Check the brake-fluid level, rear brakes (▣▣▣▣ 105).
- Checking coolant level (▣▣▣▣ 106).

## Starting

### Starting engine



### ATTENTION

#### **Sufficient gearbox lubrication only with the engine is running.**

Gearbox damage

- Do not allow the motorcycle to roll for a lengthy period of time or push it a long distance with the engine switched off.◀

- Switch on the ignition.
- » Pre-ride check is performed (▮▮▮ 83)
- » ABS self-diagnosis is in progress. (▮▮▮ 84)
- with Automatic Stability Control (ASC)<sup>OE</sup>
- » ASC self-diagnosis is in progress. (▮▮▮ 84)◀
- Select neutral or, if a gear is engaged, pull the clutch lever.

#### NOTICE

You cannot start the motorcycle with the side stand extended and a gear engaged. The engine will switch itself off if you start it with the gearbox in neutral and then engage a gear before retracting the side stand.◀

- When starting a cold engine at low ambient temperatures: disengage the clutch and turn

the twistgrip slightly to open the throttle.



- Press starter button **1**.

#### NOTICE

The start attempt is automatically interrupted if battery voltage is too low. Recharge the battery before you start the engine, or use jump leads and a donor battery to start.

See the subsection on jump starting in "Maintenance" for more details.◀

- » The engine starts.

- » If the engine refuses to start, consult the troubleshooting chart in the section entitled "Technical data". (▮▮▮ 148)

## Pre-ride check

The instrument panel runs a test of the instruments and the telltale and warning lights when the ignition is switched on: this is the so-called "Pre-Ride-Check". The test is aborted if you start the engine before it completes.

### Phase 1

The rev. counter and speedometer needles both swing to the limit values on their scales. At the same time, all the warning lights and telltale lights are switched on in succession.

### Phase 2

The general warning light changes from yellow to red.

### Phase 3

The rev. counter and speedometer needles both swing to the starting position on their scales. At the same time, all the warning lights and telltale lights switched on in the initial phase are switched off in reverse sequence.

If a needle did not move or if a warning light or telltale light did not show:

- Have the fault rectified as quickly as possible by a specialist workshop, preferably an authorised BMW Motorrad dealer.

### ABS self-diagnosis

BMW Motorrad ABS performs self-diagnosis to ensure its operability. Self-diagnosis is performed automatically when you switch on the ignition. The motorcycle has to move forward a

few metres for the wheel-speed sensors to be tested.

#### Phase 1

Test of the diagnosable system components with the vehicle at a standstill.



ABS telltale and warning light flashes.

#### Phase 2

Test of the wheel-speed sensors as the vehicle pulls away from rest.



ABS telltale and warning light flashes.

### ABS self-diagnosis completed

The ABS telltale and warning light goes out.

- Check all the telltale and warning lights.

After the ABS self-diagnosis completes, an indicator showing an ABS fault will appear.

- You can continue to ride. Bear in mind that the ABS function is not available.
- Have the fault rectified as quickly as possible by a specialist workshop, preferably an authorised BMW Motorrad dealer.

### ASC self-diagnosis

– with Automatic Stability Control (ASC)<sup>OE</sup>

BMW Motorrad ASC performs self-diagnosis to ensure its operability. Self-diagnosis is performed automatically when you switch on the ignition.

#### Phase 1

Test of the diagnosable system components with the vehicle at a standstill.

 ASC telltale and warning light slow-flashes.

## Phase 2

Test of the diagnosis-capable system components while the motorcycle is on the move (speed at least 5 km/h).

 ASC telltale and warning light slow-flashes.

## ASC self-diagnosis completed

The ASC telltale and warning light goes out.

- Check all the telltale and warning lights.

After the ABS self-diagnosis completes, an indicator showing an ABS fault will appear.

- You can continue to ride. Bear in mind that the ASC function is not available.
- Have the fault rectified as quickly as possible by a

specialist workshop, preferably an authorised BMW Motorrad dealer.

## Twistgrip brake

– with twistgrip brake<sup>OE</sup>



1 Twistgrip brake

 **WARNING**

### Stiff throttle twistgrip.

Vehicle speed can be adapted only very slowly to changing traffic conditions.

- Use the throttle twistgrip brake only for special duties and not for ordinary riding/traffic-control duty.◀

 **WARNING**

### Failure of automatic throttle closure because twist grip brake overtightened.

Loss of vehicle control. Risk of accident.

- Do not tighten the twistgrip brake past the point at which the twistgrip can return automatically to the closed-throttle position.◀

The twistgrip brake provides a means of adjusting the ease of movement of the throttle twistgrip.

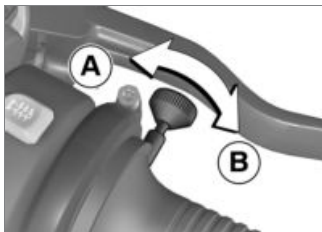

- A** movement stiffer  
**B** movement easier

## Running in Engine

- Until the first running-in check, vary the throttle opening and engine-speed range frequently; avoid riding at constant engine rpm for prolonged periods.
- Try to do most of your riding during this initial period on twisting, fairly hilly roads.
- Comply with the rpm limits for running in.



Running-in speed

<5000 min<sup>-1</sup>

- Note the mileage after which the first running-in check should be carried out.



Mileage until the first running-in check

500...1200 km

## Brake pads

New brake pads have to bed down before they can achieve their optimum friction levels. You can compensate for this initial reduction in braking efficiency by exerting greater pressure on the levers.



**WARNING**

### New brake pads.

Longer stopping distance. Risk of accident.

- Apply the brakes in good time.◀

## Tyres

New tyres have a smooth surface. This must be roughened by riding in a restrained manner at various heel angles until the tyres are run in. This running in procedure is essential if the tyres are to achieve maximum grip.



**WARNING**

### New tyres losing grip on wet roads and at extreme bank angles.

Risk of accident

- Ride carefully and avoid extremely sharp inclines.◀

## Redline warning

– with on-board computer<sup>OE</sup>

## Redline warning

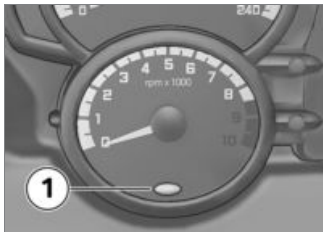

The redline warning indicates that engine revolutions have reached the rev. counter's red segment. The telltale light **1** flashes red to indicate that the engine is redlining. The signal remains active until you shift up or reduce engine speed. You can activate or deactivate the redline warning.

## Activating redline warning

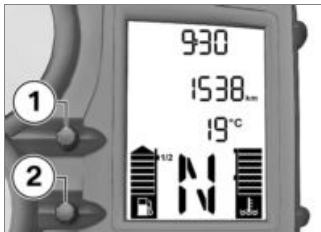

- Press button **1** and button **2** at the same time and hold them down until the reading changes.
  - » FLASH (redline warning) appears, along with ON or OFF.
- Repeatedly press button **1** until the reading shows the mode you want.
  - » ON: Redline warning activated.
  - » OFF: Redline warning deactivated.
- To save the setting, press button **1** and button **2** at the same time and hold

them down until the reading changes.

## Brakes

### How can stopping distance be minimised?

Each time the brakes are applied, a load distribution shift takes place with the load shifting forward from the rear to the front wheel. The sharper the motorcycle decelerates, the more load is shifted to the front wheel. The higher the wheel load, the more braking force can be transmitted without the wheel locking.

To optimise stopping distance, apply the front brakes rapidly and keep on increasing the force you apply to the brake lever. This makes the best possible use of the dynamic increase in load at the front wheel. Remember to pull the clutch at the same time. In the "panic braking situations" that are trained so frequently

braking force is applied as rapidly as possible and with the rider's full force applied to the brake levers; under these circumstances the dynamic shift in load distribution cannot keep pace with the increase in deceleration and the tyres cannot transmit the full braking force to the surface of the road.

BMW Motorrad ABS prevents the front wheel from locking up.

## Descending mountain passes

### WARNING

#### **Braking only with the rear brake on mountain descents.**

Brake fade. Destruction of the brakes due to overheating.

- Use both front and rear brakes, and make use of the engine's braking effect as well.◀

## Wet and dirty brakes

Wetness and dirt on the brake discs and the brake pads diminish braking efficiency.

Delayed braking action or poor braking efficiency must be reckoned with in the following situations:

- Riding in the rain or through puddles of water
- After the vehicle has been washed
- Riding on salted or gritted roads
- After work has been carried on the brakes, due to traces of oil or grease
- Riding on dirt-covered surfaces or off-road.

### WARNING

#### **Moisture and dirt.**

Diminished braking effect.

- Apply the brakes lightly while riding to remove wetness and

dirt, or dismount and clean the brakes.

- Think ahead and brake in good time until full braking efficiency is restored.◀

## Parking your motorcycle

### Side stand

- Switch off the engine.



### ATTENTION

#### **Poor ground underneath the stand.**

Risk of damage to parts if vehicle topples.

- Always check that the ground under the stand is level and firm.◀



### ATTENTION

#### **Additional weight placing strain on the side stand.**

Risk of damage to parts if vehicle topples.

- Do not sit or lean on the vehicle while it is propped on the side stand.◀
- Extend the side stand and prop the motorcycle on the stand.
- If the camber of the roadway permits, turn the handlebars all the way to the left.
- On a gradient, the motorcycle should always face uphill; select 1st gear.

## Centre stand

– with centre stand<sup>OE</sup>

- Switch off the engine.

### ATTENTION

#### **Poor ground underneath the stand.**

Risk of damage to parts if vehicle topples.

- Always check that the ground under the stand is level and firm.◀

### ATTENTION

#### **Centre stand retracts due to severe movements.**

Risk of damage to parts if vehicle topples.

- Do not lean or sit on the vehicle with the centre stand extended.◀
- Extend the centre stand and lift the motorcycle onto the stand.
- On a gradient, the motorcycle should always face uphill; select 1st gear.

## Refuelling

### WARNING

#### **Fuel is highly flammable.**

Risk of fire and explosion.

- Do not smoke. Never bring a naked flame near the fuel tank.◀

### WARNING

#### **Escape of fuel due to heat-induced expansion if fuel tank is overfilled.**

Risk of falling

- Do not overfill the fuel tank.◀

### ATTENTION

#### **Fuel attacks plastic surfaces.**

Surfaces become unsightly or dull.

- Clean plastic parts immediately after contact with fuel.◀
- Make sure the ground is level and firm and place the motorcycle on its side stand.

### NOTICE

The volume of the tank can be utilised to the full only when the

motorcycle is propped on its side stand. ◀



- Open the protective cap **1**.
- Use the ignition key to unlock fuel filler cap **2** and pop the cap open.



- Refuel with fuel of the grade stated below; do not fill the tank past the bottom edge of the filler neck.

#### NOTICE

When refuelling after running on reserve, make sure that you top up the tank to a level above reserve, as otherwise the new level will not be registered and the fuel warning light indicating that the level is down to reserve will not be switched off. ◀

#### NOTICE

The "usable fuel capacity" specified in the technical data is the quantity that the fuel tank could hold if it had been run dry and the engine had cut out due to a lack of fuel. ◀



Usable fuel capacity

approx. 15 l



Reserve fuel

approx. 3 l

- Press the fuel tank cap down firmly to close.
- Remove the key and close the protective cap.

## Fuel grade

For optimum fuel consumption, fuel should be sulphur-free or as low-sulphur as possible.

### ATTENTION

#### Leaded fuel.

Damage to catalytic converter.

- Do not attempt to run the vehicle on leaded fuel or fuel with metallic additives, e.g. manganese or iron. ◀
- You can run the engine on fuel with a maximum ethanol content of 10 %, i.e. E10.

 Recommended fuel grade

Super unleaded (max. 10 % ethanol, E10)  
95 ROZ/RON  
89 AKI

## Securing motorcycle for transportation

- Make sure that all components that might come into contact with straps used to secure the motorcycle are adequately protected against scratching. Use adhesive tape or soft cloths, for example, for this purpose.



### ATTENTION

#### Vehicle topples to side when being lifted on to stand.

Risk of damage to parts if vehicle topples.

- Secure the vehicle to prevent it toppling, preferably with the assistance of a second person. ◀
- Push the motorcycle onto the transportation flat and hold it in position: do not place it on the side stand or centre stand.

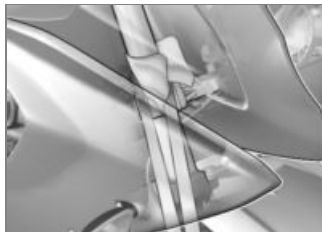

### ATTENTION

#### Trapping of components.

Component damage

- Do not trap components such as brake lines or cable legs. ◀
- At the front, secure the straps to the bottom fork bridge on

both sides and tighten the straps.



- At the rear, secure the straps to the rear footrests on both sides and tighten the straps.
- Tighten all the straps uniformly; the vehicle's suspension should be compressed tightly front and rear.

## Engineering details

Brake system with BMW Motorrad ABS .....	94
Electronic engine management with BMW Motorrad ASC.....	96
Tyre pressure monitoring (RDC) ....	97

## Brake system with BMW Motorrad ABS

### How does ABS work?

The amount of braking force that can be transferred to the road depends on factors that include the coefficient of friction of the road surface. Loose stones, ice and snow or a wet road all have much lower coefficients of friction than a clean, dry asphalt surface. The lower the coefficient of friction, the longer the braking distance.

If the rider increases braking pressure to the extent that braking force exceeds the maximum transferable limit, the wheels start to lock and the vehicle loses its directional stability; a fall is imminent. Before this situation can occur, ABS intervenes and adapts braking pressure to the maximum transferable braking force so the wheels continue to

turn and directional stability is maintained irrespective of the condition of the road surface.

### What are the effects of surface irregularities?

Surface irregularities can cause the wheels to lose contact temporarily with the road surface. If this happens the braking force that can be transmitted to the road can drop to zero. If the brakes are applied under these circumstances the ABS has to reduce braking force to ensure that directional stability is maintained when the wheels regain contact with the road surface. At this instant the ABS must assume an extremely low coefficient of friction, so that the wheels will continue to rotate under all imaginable circumstances, because this is the precondition for ensuring directional stability. As soon as it registers the actual

circumstances, the system reacts instantly and adjusts braking force accordingly to achieve optimum braking.

### Rear wheel lift

Under very severe and sudden deceleration, however, it is possible that the ABS will be unable to prevent the rear wheel from lifting clear of the ground. If this happens the outcome can be a highsiding situation in which the motorcycle can flip over.



#### WARNING

### Rear wheel lift due to severe braking.

Risk of falling

- When you brake sharply, bear in mind that ABS control cannot always be relied on to prevent the rear wheel from lifting clear of the ground.◀

## What is the design baseline for BMW Motorrad ABS?

Within the limits imposed by physics, the BMW Motorrad ABS ensures directional stability on any surface. The system is not optimised for special requirements that apply under extreme competitive situations off-road or on the track.

### Special situations

The speeds of the front and rear wheels are compared as one means of detecting a wheel's incipient tendency to lock. If the system registers implausible values for a lengthy period the ABS function is deactivated for safety reasons and an ABS fault message is issued. Self-diagnosis has to complete before fault messages can be issued.

Exceptional riding conditions can also lead to a fault message being issued:

- Riding for a lengthy period with the front wheel lifted off the ground (wheelie).
- Rear wheel rotating with the vehicle held stationary by applying the front brake (burn-out).
- Heating up with the motorcycle on the centre stand or an auxiliary stand, engine idling or with a gear engaged.
- Rear wheel locked for a lengthy period, for example while descending off-road.

If a fault message is issued on account of exceptional riding conditions, you can reactivate the ABS function by switching the ignition off and on again.

## How important is regular maintenance?

### WARNING

#### Brake system not regularly serviced.

Risk of accident

- In order to ensure that the ABS is always maintained in optimum condition, it is essential for you to comply strictly with the specified inspection intervals. ◀

#### Reserves for safety

The potentially shorter braking distances which BMW Motorrad ABS permits must not be used as an excuse for careless riding. ABS is primarily a means of ensuring a safety margin in genuine emergencies.

### WARNING

#### Braking when cornering.

Risk of accident despite ABS.

- Invariably, the rider bears responsibility for assessing road and traffic conditions and adopting his or her style of riding accordingly.
- Do not take risks that would negate the additional margin of safety offered by this system.◀

## Electronic engine management with BMW Motorrad ASC

– with Automatic Stability Control (ASC)<sup>OE</sup>

### How does ASC work?

The BMW Motorrad ASC compares the speed of rotation of the front wheel and the rear wheel. The differential is used to compute slip as a measure of the reserves of stability available at the rear wheel. If slip exceeds a certain limit the engine control in-

tervenes, adapting engine torque accordingly.

### What is the design baseline for BMW Motorrad ASC?

The BMW Motorrad ASC is designed as an assistant system for the rider during use on public roads. The extent to which the rider affects ASC control can be considerable (weight shifts when cornering, items of luggage loose on the motorcycle), especially when style of riding takes rider and machine close to the limits imposed by physics.

The system is not optimised for special requirements that apply under extreme competitive situations off-road or on the track. The BMW Motorrad ASC can be deactivated in these cases.



**WARNING**

**Risky riding.**

Risk of accident despite ASC.

- Invariably, it remains the rider's responsibility to adapt riding style to riding conditions.
- Do not take risks that would negate the additional safety offered by this system.◀

### Special situations

In accordance with the laws of physics, the ability to accelerate is restricted more and more as the bank angle increases. Consequently, there can be a perceptible reduction in acceleration out of very tight bends.

The speeds of the front and rear wheels are compared as one means of detecting the rear wheel's incipient tendency to spin or slip sideways. If the system registers implausible values for a lengthy period the ASC function is deactivated for safety reasons and an ASC fault mes-

sage is issued. Self-diagnosis has to complete before fault messages can be issued.

The following exceptional riding conditions can lead to an automatic shutdown of the BMW Motorrad ASC:

- Riding for a lengthy period with the front wheel lifted off the ground (wheelie) with ASC deactivated.
- Rear wheel rotating with the vehicle held stationary by applying the front brake (burn-out).
- Heating up with the motorcycle on the centre stand or an auxiliary stand, engine idling or with a gear engaged.

Accelerating the motorcycle to a speed in excess of 5 km/h after switching the ignition off and then on again reactivates the ASC.

If the front wheel lifts clear of the ground under severe acceleration, the ASC reduces engine torque until the front wheel regains contact with the ground. Under these circumstances, BMW Motorrad recommends rolling the throttle slightly closed so as to restore stability with the least possible delay.

When riding on a slippery surface, never snap the throttle twistgrip fully closed without pulling the clutch at the same time. Engine braking torque can cause the rear wheel to lock, with a corresponding loss of stability. The BMW Motorrad ASC is unable to control a situation of this nature.

## Tyre pressure monitoring (RDC)

- with tyre pressure monitoring (RDC)<sup>OE</sup>

### Function

A sensor integrated into each tyre measures the air temperature and the air pressure inside the tyre and transmits this information to the control unit.

Each sensor has a centrifugal-force tripswitch that does not enable transmission of the measured values until the vehicle has accelerated to about 30 km/h. The display shows "--" for each tyre until the tyre-pressure signal is received for the first time. The sensors continue to transmit the measured-value signals for approximately 15 minutes after the motorcycle comes to a stop.

## Tyre-pressure ranges

The RDC control unit differentiates between three tyre-pressure ranges, all of which are parameterised for the motorcycle:

- Tyre pressure within permitted tolerance
- Tyre pressure close to limit of permitted tolerance
- Tyre pressure outside permitted tolerance

## Temperature compensation

Tyre pressure is a temperature-sensitive variable: pressure increases as tyre air temperature rises and decreases as tyre air temperature drops. Tyre air temperature depends on ambient temperature, on the style of riding and the duration of the ride.

The tyre-pressure readings shown by the multifunction display are temperature-compensated. They are based on a tyre air temperature of 20 °C. The gauges on forecourt air lines do not compensate for temperature. The tyre pressure recorded depends on tyre air temperature. In most instances, therefore, these gauge readings will not tally with the pressures shown by the multifunction display.

## Pressure adaptation

Compare the RDC value on the multifunction display with the value in the table on the inside cover of the Rider's Manual. Then use the air line to compensate for the difference between the RDC reading and the value in the table.

Example: According to the Rider's Manual, tyre pressure should be 2.5 bar, but the reading in the multifunction display is 2.3 bar. The gauge on the air line shows 2.4 bar. You must now increase tyre pressure by the 0.2 bar difference between the value in the table and the RDC reading; when the air-line gauge shows 2.6 bar, the tyre is inflated to the correct pressure.

## Maintenance

General instructions.....	100
Toolkit .....	100
Engine oil .....	101
Brake system .....	102
Coolant .....	106
Clutch .....	107
Rims and tyres.....	108
Wheels .....	109
Front-wheel stand .....	114
Rear-wheel stand .....	116
Bulbs .....	117
Fuses.....	122
Body panels .....	123
Jump-starting.....	124
Battery.....	125

## General instructions

The "Maintenance" chapter describes straightforward procedures for checking and replacing certain wear parts.

Special tightening torques are listed as applicable. The tightening torques for the threaded fasteners on your vehicle are listed in the section entitled "Technical data".

Further information on maintenance and repair works is available from your BMW Motorrad authorised dealer in the form of a DVD.

Some of the work requires special tools and a thorough knowledge of the technology involved. If you are in doubt consult a specialist workshop, preferably your authorised BMW Motorrad dealer.

## Toolkit

### Standard toolkit

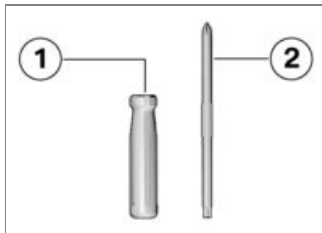

- 1 Screwdriver handle
- 2 Reversible screwdriver blade  
Phillips PH1 and Torx T25
  - Remove turn indicator bulbs, front and rear (➡ 121).
  - Replacing the brake light and rear light bulbs (➡ 120).
  - Removing centre trim panel (➡ 123).

- 2 – Removing battery (➡ 128).

### Service toolkit

- with service toolkit<sup>OA</sup>

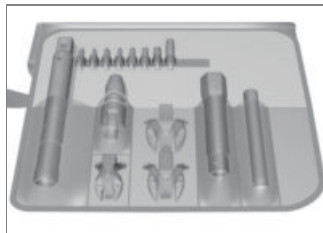

BMW Motorrad has assembled a service toolkit that is ideal for carrying out extended work (e.g. removing and installing wheels) on this motorcycle. You can obtain the tools set from your authorised BMW Motorrad dealer.

## Engine oil

### Checking engine oil level

#### ATTENTION

The oil level varies with the temperature of the oil. The higher the temperature, the higher the level of oil in the sump.

Misinterpretation of the oil level

- Check the oil level only after a lengthy ride or when the engine is at operating temperature.◀
- Wipe the area around the oil filler neck clean.
- Allow the engine to idle until the fan starts up, then allow it to idle one minute longer.
- Switch off the engine.
- Make sure the engine is at operating temperature and hold the motorcycle upright.

- with centre stand<sup>OE</sup>
- Check that the engine is at operating temperature, make sure the ground is level and firm and place the motorcycle on its centre stand.◀



#### ATTENTION

**Vehicle topples to side when being lifted on to stand.**

Risk of damage to parts if vehicle topples.

- Secure the vehicle to prevent it toppling, preferably with the assistance of a second person.◀

- Remove oil dipstick **1**.

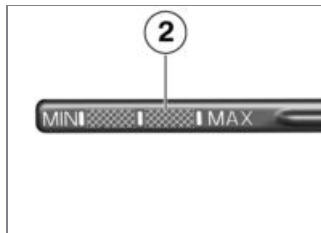

- Use a dry cloth to wipe gauge length **2** clean.
- Seat the oil dipstick on the oil filler neck, but do not engage the threads.
- Remove the oil dipstick and check the oil level.

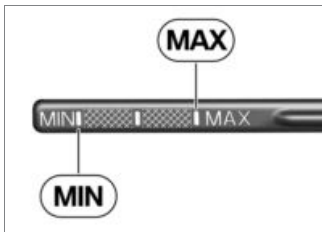

Engine oil, specified level

Between MIN and MAX marks



Engine oil, quantity for topping up

Viscosity class

max 0.4 l (Difference between MIN and MAX)

If the oil level is below the MIN mark:

- Topping up the engine oil (►► 102).

If the oil level is above the MAX mark:

- Have the oil level corrected by a specialist workshop, preferably an authorised BMW Motorrad dealer.
- Install the oil dipstick.

## Top up the engine oil



### ATTENTION

#### Not enough or too much engine oil.

Engine damage

- Always make sure that the oil level is correct.◀
- Make sure the ground is level and firm and place the motorcycle on its stand.
- Wipe the area around the filler neck clean.



- Remove oil dipstick **1**.
- Check engine oil level (►► 101).
- Top up the engine oil to the specified level.
- Check engine oil level (►► 101).
- Install the oil dipstick.

## Brake system

### Check operation of brakes

- Pull the front brake lever.
  - » The pressure point must be clearly perceptible.
- Press the footbrake lever.
  - » The pressure point must be clearly perceptible.

If pressure points are not clearly perceptible:

- Have the brakes checked by a specialist workshop, preferably an authorised BMW Motorrad dealer.

## Checking front brake pad thickness

- Make sure the ground is level and firm and place the motorcycle on its stand.



- Visually inspect the front left and right brake pads to ascertain their thickness. Viewing direction: between wheel and

front suspension toward the brake calipers.



 Brake-pad wear limit, front

min 1.0 mm (Friction pad only, without backing plate. The wear indicators (grooves) must be clearly visible.)

If the wear indicating marks are no longer clearly visible:

 **WARNING**

**Brake-pad thickness less than permissible minimum.**

Diminished braking effect. Damage to the brakes.

- In order to ensure the dependability of the brake system, do not permit the brake pads to wear past the minimum permissible thickness. ◀
- Have the brake pads replaced by a specialist workshop, preferably an authorised BMW Motorrad dealer.

## Checking rear brake pad thickness

- Make sure the ground is level and firm and place the motorcycle on its stand.



- Visually inspect the brake pads to ascertain their thickness. Viewing direction: from the rear toward the brake caliper.

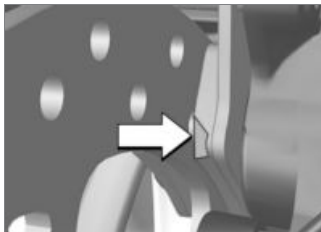

Brake-pad wear limit,  
rear

min 1.0 mm (Friction pad only, without backing plate. The grooved edge must be clearly visible.)

If the wear indicating mark is no longer visible:



**WARNING**

**Brake-pad thickness less than permissible minimum.**

Diminished braking effect. Damage to the brakes.

- In order to ensure the dependability of the brake system, do not permit the brake pads to wear past the minimum permissible thickness.◀
- Have the brake pads replaced by a specialist workshop, preferably an authorised BMW Motorrad dealer.

## Checking brake-fluid level, front brakes



**WARNING**

**Not enough brake fluid in brake fluid reservoir.**

Considerably reduced braking power due to air in the brake system.

- Check the brake-fluid level at regular intervals.◀
- Make sure the ground is level and firm and hold the motorcycle upright.

– with centre stand<sup>OE</sup>

- Make sure the ground is level and firm and place the motorcycle on its centre stand.<
- Move the handlebars to the straight-ahead position.

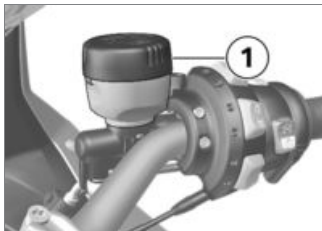

- Check the brake fluid level in front reservoir **1**.

#### NOTICE

Wear of the brake pads causes the brake fluid level in the reservoir to sink.<



 Brake fluid level, front
Brake fluid, DOT4
Do not permit the brake fluid level to drop below the MIN mark.

If the brake fluid level drops below the permitted level:

- Have the defect rectified as quickly as possible by a specialist workshop, preferably an authorised BMW Motorrad dealer.

## Check the brake-fluid level, rear brakes

### WARNING

#### Not enough brake fluid in brake fluid reservoir.

Considerably reduced braking power due to air in the brake system.

- Check the brake-fluid level at regular intervals.<
- Make sure the ground is level and firm and hold the motorcycle upright.
- with centre stand<sup>OE</sup>
- Make sure the ground is level and firm and place the motorcycle on its centre stand.<



- Check the brake fluid level in rear reservoir **1**.



### NOTICE

Wear of the brake pads causes the brake fluid level in the reservoir to sink. ◀



Brake fluid level, rear

Brake fluid, DOT4

It is impermissible for the brake fluid level to drop below the MIN mark.

If the brake fluid level drops below the permitted level:

- Have the defect rectified as quickly as possible by a specialist workshop, preferably an authorised BMW Motorrad dealer.

## Coolant

### Checking coolant level

- Make sure the ground is level and firm and place the motorcycle on its stand.



- Check the coolant level in expansion tank **1**. For better visibility, shine a light at the bottom of the tank.



Coolant, specified level

Between MIN and MAX marks on the expansion tank

If the coolant drops below the permitted level:

- Have the coolant system checked by a specialist workshop, preferably an authorised BMW Motorrad dealer.

## Clutch

### Checking clutch function

- Pull the clutch lever.
    - » The pressure point must be clearly perceptible.
- If the pressure point is not clearly perceptible:
- Have the clutch checked by a specialist workshop, preferably an authorised BMW Motorrad dealer.

### Checking the clutch play



- Operate the clutch lever until resistance can be felt whilst observing the notch between edges **1** and **2** in the manual valve.
    - » The inner edge **1** of the brake cable should be able to move up to outer edge **2** of the handbrake fitting.
- Clutch play is out of tolerance:
- Adjusting clutch play (▣▶ 108).

## Adjusting clutch play

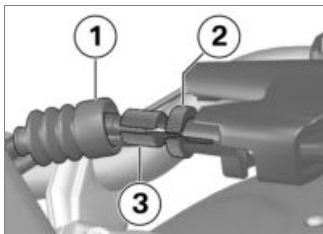

- Move the rubber grommet **1** to one side.
- Slacken nut **2**.
- To increase clutch play: screw the adjusting screw **3** into the manual valve.
- To reduce clutch play: unscrew the adjusting screw **3** from the manual valve.
- Checking the clutch play (►► 107).
- Tighten nut **2** while holding the adjusting screw **3** in position.
- Fasten the rubber grommet **1** over the nut.

## Rims and tyres

### Checking rims

- Make sure the ground is level and firm and place the motorcycle on its stand.
- Visually inspect the rims for defects.
- Have any damaged rims inspected by a specialist workshop and replaced if necessary, preferably by an authorised BMW Motorrad dealer.

### Check the tyre tread depth



#### WARNING

#### Riding with badly worn tyres

Risk of accident due to impaired handling

- If applicable, have the tyres changed in good time before they wear to the minimum tread depth permitted by law.◀

- Make sure the ground is level and firm and place the motorcycle on its stand.
- Measure the tyre tread depth in the main tread grooves with wear marks.



#### NOTICE

Wear indicators are built into the main profile grooves on each tyre. The tyre is worn out when the tyre tread has worn down to the level of the marks. The locations of the marks are indicated on the edge of the tyre, e.g. by the letters TI, TWI or by an arrow.◀

If the tyre tread is worn to minimum:

- Replace tyre or tyres, as applicable.

## Wheels

### Tyre recommendation

For each size of tyre, BMW Motorrad tests and classifies as roadworthy certain makes. BMW Motorrad cannot assess the suitability or provide any guarantee of road safety for other tyres.

BMW Motorrad recommends using only tyres tested by BMW Motorrad.

Detailed information is available from your authorised BMW Motorrad dealer or in the internet at

**bmw-motorrad.com**

### Effect of wheel size on ABS

The wheel size has a large influence on the functionality of the ABS system. In particular, the diameter and the width of a vehicle's wheels are programmed

into the control unit and are fundamental to all calculations. Any change in these influencing variables, caused for example by a switch to non-standard installed wheels, can have serious effects on the performance of the control systems.

The sensor rings are essential for correct road-speed calculation, and they too must match the motorcycle's control systems and consequently cannot be changed.

If you decide that you would like to fit non-standard wheels to your motorcycle, it is very important to consult a specialist workshop beforehand, preferably an authorised BMW Motorrad dealer. In some cases, the data programmed into the control units can be changed to suit the new wheel sizes.

### RDC adhesive label

– with tyre pressure monitoring (RDC)<sup>OE</sup>

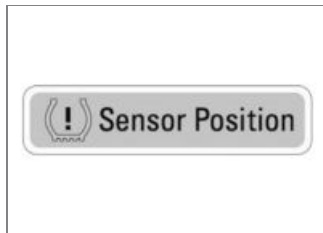

### ATTENTION

**Tyre removal not in compliance with correct procedure.**

Damage to RDC sensors.

- Be sure to explain to the specialist workshop or authorised BMW Motorrad dealer that the wheel is fitted with an RDC sensor. ◀

If the motorcycle is equipped with RDC, each wheel rim bears

an adhesive label indicating the position of the RDC sensor.

## Removing front wheel

- Make sure the ground is level and firm and place the motorcycle on its stand.

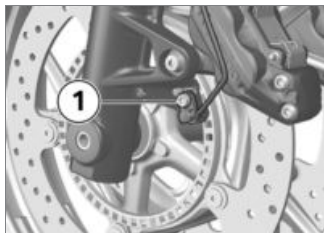

- Remove screw **1** and remove the wheel-speed sensor from its bore.

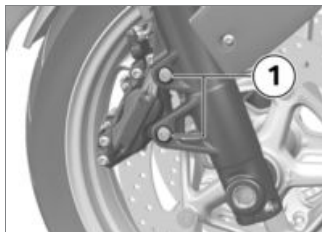

### ATTENTION

#### Brake pads pushed together with brake caliper removed.

It is not possible to slip the brake caliper over the brake disc.

- Do not operate the brake lever while a brake caliper has been removed. ◀
- Remove screws **1** of the brake calipers on left and right.

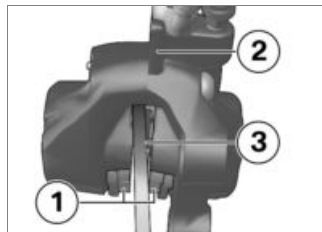

- Force the brake pads **1** slightly apart by rocking brake caliper **2** back and forth against brake disc **3**.
- Mask off the parts of the wheel rim that could be scratched in the process of removing the brake calipers.
- Carefully pull the brake calipers back and out until clear of the brake discs.
- Place the motorcycle on an auxiliary stand; BMW Motorrad recommends the BMW Motorrad rear-wheel stand.

- Installing the rear-wheel stand (➔ 116).  
– with centre stand<sup>OE</sup>
- Make sure the ground is level and firm and place the motorcycle on its centre stand.<
- Raise front of motorcycle until the front wheel can turn freely. BMW Motorrad recommends the BMW Motorrad front-wheel stand for lifting the motorcycle.
- Install the front-wheel stand (➔ 114).

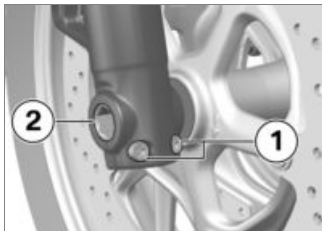

- Slacken axle clamping screws **1**.

- Remove quick-release axle **2**, while supporting the wheel.
- Roll the front wheel forward to remove.



- Remove spacing bushing **1** from the left-hand side of the wheel hub.

## Installing front wheel

### WARNING

#### Use of a non-standard wheel.

Malfunctions in operation of ABS.

- See the information on the effect of wheel size on the

ABS system at the start of this chapter.<



### ATTENTION

#### Tightening threaded fasteners to incorrect tightening torque.

Damage, or threaded fasteners work loose.

- Always have the security of the fasteners checked by a specialist workshop, preferably an authorised BMW Motorrad dealer.<

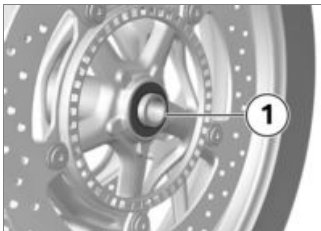

- Slip spacing bushing **1** into the wheel hub on the left-hand side.



### ATTENTION

#### Front wheel installed wrong way round.

Risk of accident

- Note direction-of-rotation arrows on tyre or rim. ◀
- Roll the front wheel between the front wheel suspension (telescopic forks).

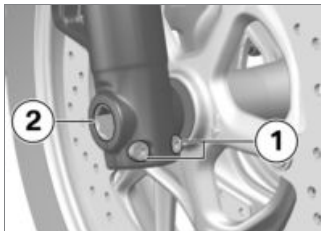

- Raise the front wheel, insert quick-release axle **2** and tighten to specified torque.



Quick-release axle in telescopic forks

50 Nm

- Tighten axle clamping screws **1** to the specified tightening torque.



Clamp of quick-release axle

Tightening sequence: Tighten screws six times in alternate sequence

19 Nm

- Removing the front-wheel stand.
- without centre stand<sup>OE</sup>
- Remove the auxiliary stand. ◀
- Ease the brake calipers on to the brake discs.

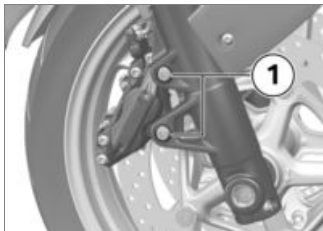

- Install screws **1** and tighten to the specified tightening torque.



Brake caliper on fork leg

30 Nm

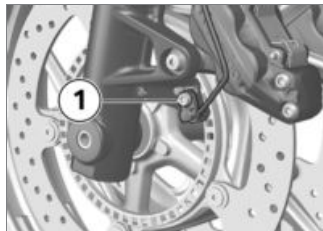

- Insert the wheel-speed sensor into the bore and install screw **1**.
- Remove the adhesive tape from the wheel rim.
- Operate the brake several times until the brake pads are bedded.

### Removing rear wheel

- Make sure the ground is level and firm and place the motorcycle on a suitable auxiliary stand; BMW Motorrad recommends the BMW Motorrad rear-wheel stand.

- Installing the rear-wheel stand (→ 116).  
– with centre stand<sup>OE</sup>
- Make sure the ground is level and firm and place the motorcycle on its centre stand.<
- Engage first gear.



- Remove studs **1** from the rear wheel, while supporting the wheel.
- Roll the rear wheel out toward the rear.

## Installing the rear wheel

### WARNING

#### Use of a non-standard wheel.

Malfunctions in operation of ABS.

- See the information on the effect of wheel size on the ABS system at the start of this chapter.◀

### ATTENTION

#### Tightening threaded fasteners to incorrect tightening torque.

Damage, or threaded fasteners work loose.

- Always have the security of the fasteners checked by a specialist workshop, preferably an authorised BMW Motorrad dealer.◀
- Seat the rear wheel on the rear-wheel adapter.



- Tighten screws **1** to specified torque in diagonally opposite sequence.



Rear wheel to drive shaft

Tightening sequence: tighten in a crosswise sequence

60 Nm

- without centre stand<sup>OE</sup>
- Remove the auxiliary stand.◀

## Front-wheel stand

### Installing the front-wheel stand

### ATTENTION

#### Use of the BMW Motorrad front wheel stand without also accompanying use of auxiliary stand.

Risk of damage to parts if vehicle topples.

- Place the motorcycle on an auxiliary stand before lifting the front wheel with the BMW Motorrad front-wheel stand.◀
- Place the motorcycle on an auxiliary stand; BMW Motorrad recommends the BMW Motorrad rear-wheel stand.
- Installing the rear-wheel stand (➡ 116).

– with centre stand<sup>OE</sup>

- Make sure the ground is level and firm and place the motorcycle on its centre stand.◀
- Use basic stand with front-wheel adapter. The basic stand and its accessory components are available from your BMW Motorrad authorised dealer.

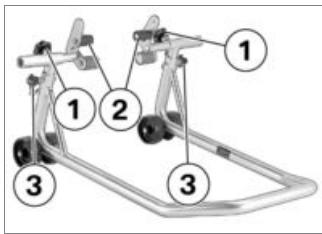

- Slacken securing screw **1**.
- Push the two adapters **2** apart until the telescopic forks fit between them.

- Use locating pins **3** to set the front-wheel stand to the desired height.
- Centre the front-wheel stand relative to the front wheel and push it against the front axle.

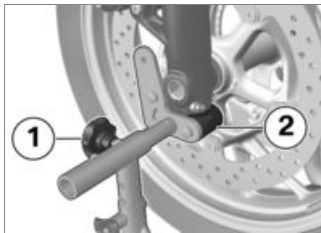

- Align the two adapters **2** so that the telescopic forks are securely seated.
- Tighten securing screw **1**.

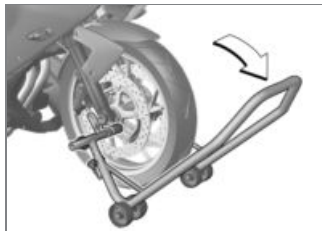

- Apply uniform pressure to push the front-wheel stand down and raise the motorcycle.

– with centre stand<sup>OE</sup>



#### ATTENTION

#### **Centre stand retracts if vehicle lifted too high.**

Risk of damage to parts if vehicle topples.

- When raising the vehicle, make sure that the centre stand remains on the ground.
- If necessary, adjust the height of the front-wheel stand.◀

- Make sure the motorcycle is standing firmly.◀

## Rear-wheel stand

### Install the rear-wheel stand

- Make sure the ground is level and firm and place the motorcycle on its stand.
- Use basic stand with rear axle adapter. The basic stand and its accessory components are available from your BMW Motorrad authorised dealer.

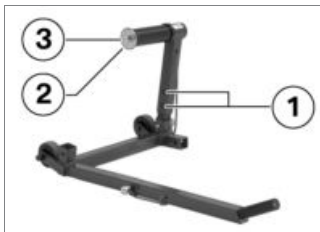

- Use screws **1** to set the rear-wheel stand to the desired height.
- Remove retaining disc **2**. To do so, press release button **3**.



- Push the rear-wheel stand from the right onto the rear axle.
- Push the retaining disc on from the left, while holding the unlock button down.



- Hold the motorcycle upright and at the same time press the

handle of the stand back until both rollers of the stand are on the ground.

- Then press the handle down to the ground.

## Bulbs

### Replacing low-beam and/or high-beam headlight bulb

- Make sure the ground is level and firm and place the motorcycle on its stand.
- Switch off the ignition.

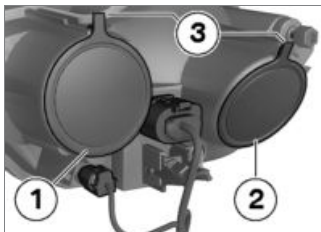

- Remove cover **1** for the high-beam headlight or cover **2** for the low-beam headlight as applicable, by pulling lever **3**.

#### NOTICE

The positions of the plug, the spring wire retainer and the bulb might not be as illustrated below. ◀

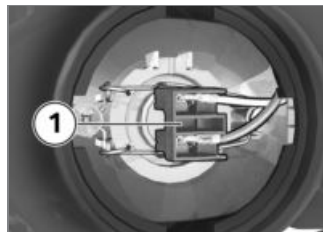

- Disconnect plug **1**.

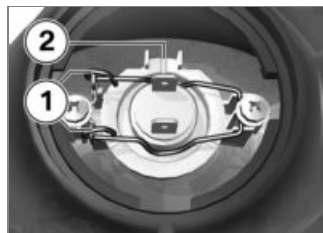

- Disengage spring wire clips **1** from the fastenings and swing them aside.
- Remove bulb **2**.

- Replace the defective bulb.



H7 / 12 V / 55 W

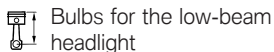

H7 / 12 V / 55 W

- Hold the new bulb by the base only, in order to keep the glass free of foreign matter.

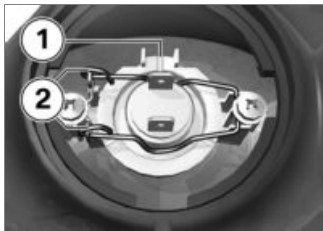

- Insert bulb **1**, making sure that the tab is correctly positioned.

- Close and lock spring wire clips **2**.

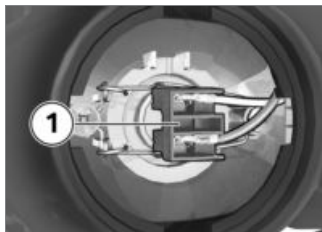

- Connect plug connection **1**.

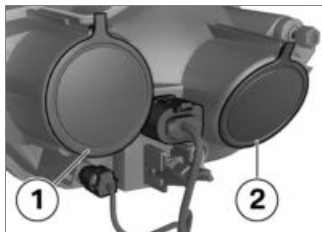

- Install cover **1** for the high-beam headlight or cover **2** for the low-beam headlight.

## Replacing bulb for parking light

- Make sure the ground is level and firm and place the motorcycle on its stand.
- Switch off the ignition.

### NOTICE

Turn the handlebars to the left to facilitate access. ◀



- Disconnect plug **1**.



- Replace the defective bulb.

 Bulb for parking light

W5W / 12 V / 5 W

- Use a clean, dry cloth to hold the new bulb in order to keep the glass free of foreign matter.

- Remove socket **1** by turning it counter-clockwise.

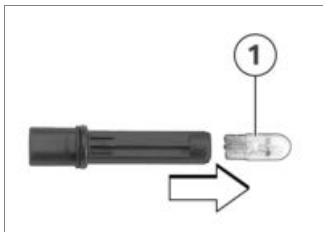

- Remove bulb **1** from the socket.

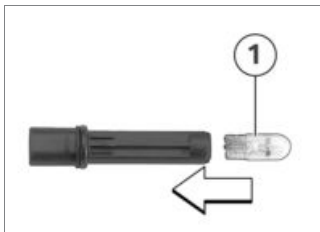

- Press bulb **1** into the socket.



- Turn socket **1** clockwise to install.



- Connect plug connection **1**.

## Replacing the brake light and rear light bulbs

– with LED rear light<sup>OA</sup>

- The LED rear light can be replaced only as a complete unit. Consult a specialist workshop, preferably an authorised BMW Motorrad dealer. <

– without LED rear light<sup>OA</sup>

- Make sure the ground is level and firm and place the motorcycle on its stand.
- Switch off the ignition.

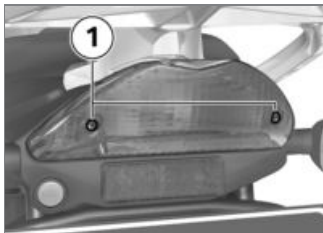

- Remove screws **1**.

- Pull the bulb housing to the rear to remove.

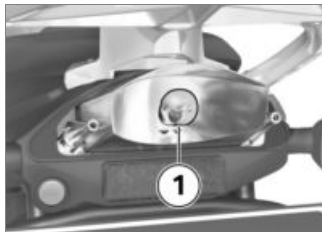

- Press bulb **1** into its socket and turn it counter-clockwise to remove.
- Replace the defective bulb.

 Bulb for tail light/brake light

P21/5W / 12 V / 5 W / 21 W

- Use a clean, dry cloth to hold the new bulb in order to keep the glass free of foreign matter.

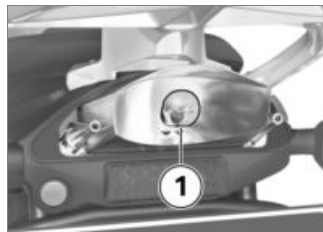

- Press bulb **1** into its socket and turn it clockwise to install.

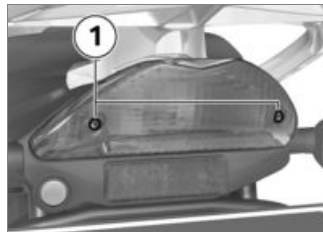

- Hold the bulb housing in position and install screws **1**. <

## Replace LED flashing turn indicators

– with LED turn indicators<sup>OE</sup>

- The LED flashing turn indicators can be replaced only as a complete unit. Consult a specialist workshop, preferably an authorised BMW Motorrad dealer.◀

## Removing turn indicator bulbs, front and rear

- Make sure the ground is level and firm and place the motorcycle on its stand.
- Switch off the ignition.



- Remove screw **1**.



- Pull the glass out of the reflector housing at the threaded-fastener side.

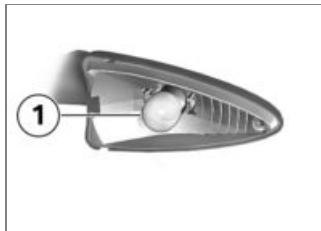

- Turn bulb **1** counter-clockwise and remove it from the bulb housing.

## Installing turn indicator bulbs, front and rear

- Replace the defective bulb.

 Bulbs for flashing turn indicators, front

RY10W / 12 V / 10 W

- Use a clean, dry cloth to hold the new bulb in order to keep the glass free of foreign matter.

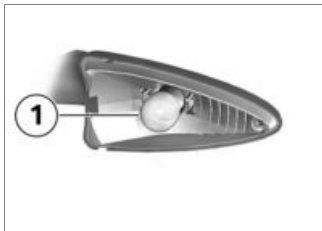

- Turn bulb **1** clockwise to install it in the bulb housing.



- Working from the inboard side, insert the glass into the bulb housing and close the housing.



- Install screw **1**.

## Fuses

### Replacing fuses

#### ATTENTION

#### Jumpering of blown fuses.

Risk of short-circuit and fire.

- Always replace a defective fuse with a new fuse of the same amperage.◀

#### NOTICE

Deviating from the base motorcycle, authority-specific electrical

consumers are protected using conventional plug-in fuses.◀

#### NOTICE

Consult a specialist workshop, preferably an authorised BMW Motorrad dealer if you suspect faulty fuses.◀

- Switch off the ignition.
- Removing seat (→ 65).

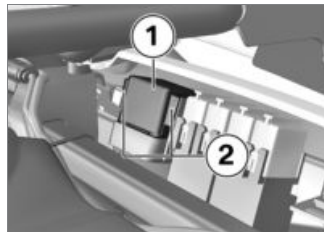

- Disengage fuse cover **1** by squeezing retainers **2** together and lift the cover up to remove.

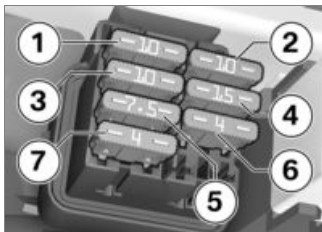

- Consult the fuse assignment diagram and replace the defective fuse.



## NOTICE

If fuse defects recur frequently have the electric circuits checked by a specialist workshop, preferably an authorised BMW Motorrad dealer. ◀

- Push fuse cover **1** onto the fuse box.
- » The retainers engage with an audible click.
- Install the seat (▶▶▶ 66).

## Body panels

### Removing centre trim panel

- Removing seat (▶▶▶ 65).

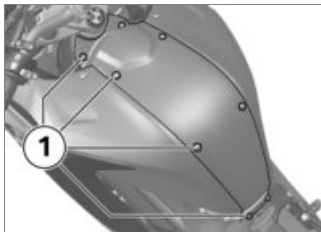

- Remove four screws **1** on left and right and remove the centre trim panel.

## Installing centre trim panel

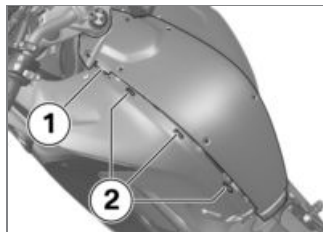

- Slip the centre trim panel underneath the left and right side panels at position **1** and then seat it in guides **2** on left and right.

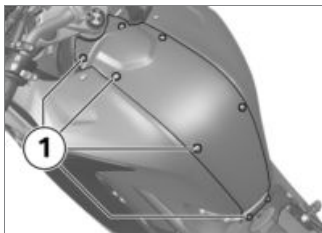
**ATTENTION****Missing plastic washer for painted components.**

Paint damage

- Install plastic washers underneath the screw heads.◀
- Install four screws **1** on left and right.



Trim panels

2 Nm

- Install the seat (▶▶ 66).

**Jump-starting****ATTENTION****Excessive current flowing when the motorcycle is jump-started**

Wiring smoulders/ignites or damage to the on-board electronics

- If the motorcycle has to be jump-started connect the leads to the battery terminals; never attempt to jump-start the engine by connecting leads to the on-board socket.◀

**ATTENTION****Contact between crocodile clips of jump leads and vehicle.**

Risk of short-circuit

- Use jump leads fitted with fully insulated crocodile clips at both ends.◀

**ATTENTION****Jump-starting with a voltage greater than 12 V.**

Damage to the on-board electronics.

- Make sure that the battery of the donor vehicle has a voltage rating of 12 V.◀
- Removing seat (▶▶ 65).
- Removing centre trim panel (▶▶ 123).
- When jump-starting the engine, do not disconnect the battery from the on-board electrical system.

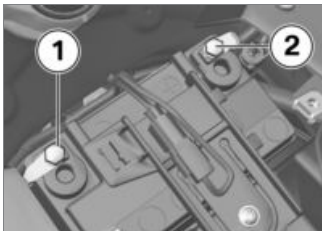

- Begin by connecting one end of the red jump lead to the positive terminal of the discharged battery and the other end to the positive terminal of the donor battery (positive on this vehicle: position **2**).
- Then connect one end of the black jump lead to the negative terminal of the donor battery and the other end to the negative terminal of the discharged battery (negative on this vehicle: position **1**).
- Run the engine of the donor vehicle during jump-starting.

- Start the engine of the vehicle with the discharged battery in the usual way; if the engine does not start, wait a few minutes before repeating the attempt in order to protect the starter motor and the donor battery.
- Allow both engines to idle for a few minutes before disconnecting the jump leads.
- Disconnect the jump lead from the negative terminals first, then disconnect the second lead from the positive terminals.

#### **NOTICE**

Do not use proprietary start-assist sprays or other products to start the engine. ◀

- Installing centre trim panel (▶▶▶ 123).
- Install the seat (▶▶▶ 66).

## Battery

### Maintenance instructions

Correct upkeep, recharging and storage will prolong the life of the battery and are essential if warranty claims are to be considered.

Compliance with the points below is important in order to maximise battery life:

- Keep the surface of the battery clean and dry.
- Do not open the battery.
- Do not top up with water.
- Be sure to read and comply with the instructions for charging the battery on the following pages.
- Do not turn the battery upside down.

**ATTENTION****On-board electronics (e.g. clock) draining connected battery.**

Battery is deep-discharged; this voids the guarantee.

- Connect a float charger to the battery if the motorcycle is to remain out of use for more than four weeks. ◀

**NOTICE**

BMW Motorrad has developed a float charger specially designed for compatibility with the electronics of your motorcycle. Using this charger, you can keep the battery charged during long periods of disuse, without having to disconnect the battery from the motorcycle's on-board systems. You can obtain additional information from your authorised BMW Motorrad dealer. ◀

– with auxiliary battery<sup>OE</sup>

The motorcycle's starting capability is independent of the state of charge of the second battery, as the second battery is disconnected from the onboard electrical system when the engine is not running.

Charging and float charging of the motorcycle's main battery have no effect on the second battery. It must be dealt with separately.

**Charge battery when connected**

- Disconnect devices plugged into the sockets.

**ATTENTION****Charging connected battery via the battery terminals.**

Damage to the on-board electronics.

- Disconnect the battery at the battery terminals before charging. ◀

**ATTENTION****Unsuitable battery chargers connected to an on-board socket.**

Damage to charger and to frame and suspension electronics.

- Use suitable BMW chargers. The suitable charger is available from your authorised BMW Motorrad dealer. ◀

**ATTENTION****Charging a fully discharged battery via the on-board socket or the extra socket.**

Damage to the on-board electronics.

- If a battery has discharged to the extent that it is completely flat (battery voltage less than 9 V, status-indicator lights and

multifunction display remain off when the ignition is switched on) **it has to be disconnected from the on-board circuits** and re-charged with the charger connected directly to the battery posts.◀

- Charge via the charging socket, with the battery connected to the motorcycle's on-board electrical system.

#### NOTICE

The motorcycle's on-board electronics know when the battery is fully charged. The on-board socket is switched off when this happens.◀

- If a second battery is installed, with the motorcycle battery connected to the on-board electrical system as described above, charge it via the **front** charging socket.

- With the second battery connected to the motorcycle's on-board electrical system, charge it via the socket at the rear left.

#### NOTICE

The second battery is wired directly to the rear socket and is not connected to the on-board electrics. Consequently, the restrictions regarding the type of charger to be used do not apply for the second battery.◀



Engine rpm, starting from which the second battery is charged

min 2000 min<sup>-1</sup>

- Comply with the operating instructions of the charger.

#### NOTICE

If you are unable to charge the battery through the on-board socket, you may be using a char-

ger that is not compatible with your motorcycle's electronics. If this happens, disconnect the battery from the on-board systems and connect the charger directly to the battery.◀

### Charging battery when disconnected

- Charge the battery using a suitable charger.
- Comply with the operating instructions of the charger.
- After charging, remove the pole terminal of the charger from the battery posts.

#### NOTICE

The battery has to be recharged at regular intervals in the course of a lengthy period of disuse. See the instructions for caring for your battery. Always fully recharge the battery before restoring it to use.◀

## Removing battery

- with single seat with two-way radio box<sup>OE</sup>
- Remove seat with optional extras (►► 66).◀
- Removing centre trim panel (►► 123).
- Make sure the ground is level and firm and place the motorcycle on its stand.
- with alarm system (DWA)<sup>OE</sup>
- If applicable, switch off the anti-theft alarm.◀
- Switch off the ignition.

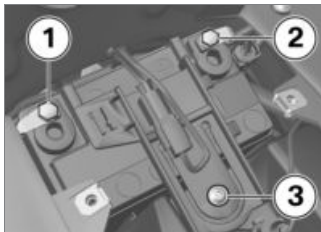

### ATTENTION

#### Battery not disconnected in accordance with correct procedure.

Risk of short-circuit

- Always proceed in compliance with the specified disconnection sequence.◀
- Disconnect negative lead **1** first.
- Then disconnect positive lead **2**.
- Remove screw **3** and remove the battery holder.

- Lift the battery up and out; work it slightly back and forth if it is difficult to remove.

## Installing battery



### NOTICE

If the battery was disconnected from the motorcycle for a prolonged period of time it will be necessary to enter the current date in the instrument panel, in order to ensure that the service-due indicator functions correctly. If you want to have the date set consult a specialist workshop, preferably an authorised BMW Motorrad dealer.◀

- Switch off the ignition.
- Insert the battery into the battery compartment, with the positive terminal on the right in the direction of travel.

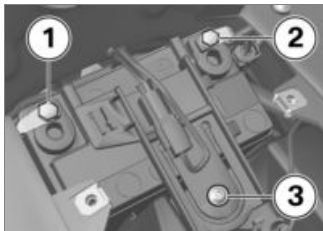

- Slip the battery holder over the battery and install screw **3**.



## ATTENTION

### Battery not connected in accordance with correct procedure.

Risk of short-circuit

- Always proceed in compliance with the specified installation sequence.◀
- Connect positive lead **2** to the battery's positive terminal.
- Connect negative lead **1** to the battery's negative terminal.



Cable harness on the battery

5 Nm

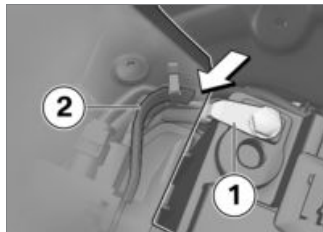

- Please ensure that the battery minus line **1** has sufficient clearance from the **arrow** to the relay carrier **2**.
- Installing centre trim panel (▣▶ 123).  
– with single seat with two-way radio box<sup>OE</sup>
- Install seat with optional extras (▣▶ 66).◀

- Setting clock (▣▶ 47).

## Removing and installing the second battery

– with auxiliary battery<sup>OE</sup>

- Consult a specialist workshop, preferably an authorised BMW Motorrad dealer, for removing and installing the second battery.



## **Accessories**

General instructions.....	132
Power sockets .....	132
Cases.....	133
Case for special vehicle .....	136
Topcase .....	137
Two-way radio box.....	140
Fire extinguisher .....	140

## General instructions

### CAUTION

#### Use of other-make products.

Safety risk

- BMW Motorrad cannot examine or test each product of outside origin to ensure that it can be used on or in connection with BMW vehicles without constituting a safety hazard. Country-specific official authorisation does not suffice as assurance. Tests conducted by these instances cannot make provision for all operating conditions experienced by BMW vehicles and, consequently, they are not sufficient in some circumstances.
- Use only parts and accessories approved by BMW for your vehicle. ◀

BMW has conducted extensive testing of the parts and ac-

cessory products to establish that they are safe, functional and suitable. Consequently, BMW accepts product liability. BMW accepts no liability whatsoever for parts and accessories that it has not approved.

Whenever you are planning modifications, comply with all the legal requirements. Make sure that the vehicle does not infringe the national road-vehicle construction and use regulations applicable in your country. Your BMW Motorrad dealer can offer expert advice on the choice of genuine BMW parts, accessories and other products. You can examine all the optional accessories from BMW Motorrad by visiting our website:

**"[www.bmw-motorrad.com](http://www.bmw-motorrad.com)".**

## Power sockets

### Connection of electrical devices

- You can start using electrical devices connected to the motorcycle's sockets only when the ignition is switched on.

### Cable routing

- The cables from the power sockets to the auxiliary devices must be routed in such a way that they do not impede the rider.
- The cable routing should not restrict the steering angle or obstruct handling.
- The cables must not be trapped.

### Automatic shutdown

- The sockets will be automatically switched off during the start procedure.

- The power supply to the sockets is switched off no more than 15 minutes after the ignition is switched off, in order to prevent overloading of the on-board electrics. Low-wattage electrical accessories might not be recognised by the vehicle's electronics. In such cases, power sockets are switched off very shortly after the ignition is turned off.
- If the battery charge state is too low to maintain the motorcycle's start capability, the power sockets are switched off.
- The power sockets are also switched off when the maximum load capability as stated in the technical data is exceeded.

## Cases

### Opening cases

- with cases<sup>OE</sup>

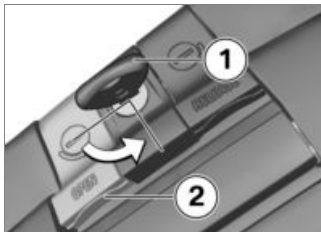

- Turn the key **1** to position OPEN.
- Pull the grey release lever **2** (OPEN) all the way up and simultaneously open the case lid.

### Closing cases

- with cases<sup>OE</sup>



- Turn the key **1** to position OPEN.
- Press catches **2** of the case lid into retainers **3**. Check that nothing is trapped between the lid and the case.
- Pull the grey release lever **4** (OPEN) all the way up and simultaneously open the case lid.
  - » The lid engages with an audible click.
- Turn key **1** in the case lock to the position in which it is parallel with the direction of travel and remove the key.

## Removing cases

– with cases<sup>OE</sup>

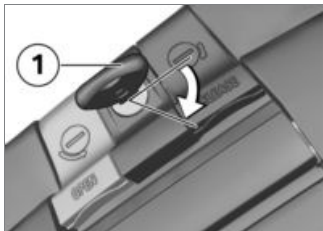

- Turn the key **1** to position RELEASE.



- Pull the black release lever **1** (RELEASE) up and simultaneously pull the case out.
- Then lift the case out of the bottom holder.

## Install cases

– with cases<sup>OE</sup>

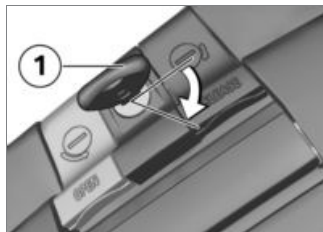

- Turn the key **1** to position RELEASE.

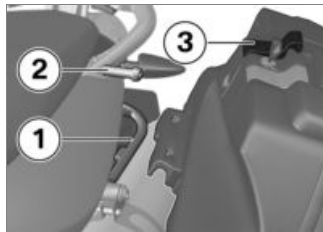

- Position the case in case holder **1**, then pivot it until it is seated at mount **2**.
- Pull the black release lever **3** (RELEASE) up and simultan-

ously push the case into the upper holder **2**.



- Push black release lever **3** (RELEASE) down until it engages.
- Turn the key in the case lock to the position in which it is parallel with the direction of travel and remove the key.

## Maximum payload and maximum permissible speed

Note the maximum permissible payload and the speed limit for riding with cases fitted, as stated on the label inside the case.

Contact your authorised BMW Motorrad dealer if you cannot find your combination of vehicle and cases on the label.

The values for the combination described here are as follows:

	Maximum permissible speed for riding with cases fitted to the motorcycle
	– with cases <sup>OA</sup>
	see label in case◀
	Payload of cases
	– with cases <sup>OA</sup>
	see label in case◀

## Secure attachment

- with cases<sup>OE</sup>

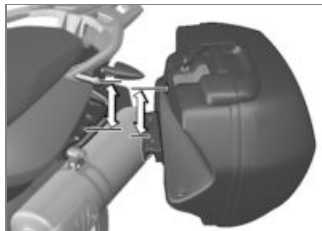

If a case wobbles or is difficult to fit, it has to be adapted to the gap between the top and bottom holders.

### **WARNING**

#### **Case installation not in compliance with correct procedure.**

Impairment of road safety.

- Cases may not wobble and must be secured free from play. Re-adjust the retainer if play develops over the course of time.◀



Screws **1** inside the case allow you to make this adjustment.

## Case for special vehicle

### Opening cases

- with cases, painted, with holder for special vehicle<sup>OE</sup>

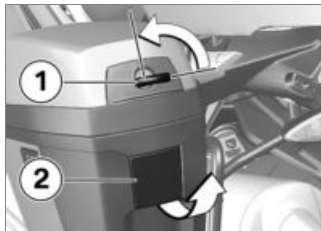

- Open case lock **1** using the key **arrow**.
- Pull up latch **2 arrow** and open the case lid.

### Closing cases

- with cases, painted, with holder for special vehicle<sup>OE</sup>
- Close the case lid and press it shut until the latch engages. Check that nothing is trapped between the lid and the case.

## Removing cases

- with cases, painted, with holder for special vehicle<sup>OE</sup>
- Open cases (→ 136).

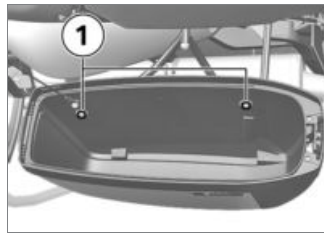

- Remove screws **1**.
- Lift the case up to remove.

## Installing cases

- with cases, painted, with holder for special vehicle<sup>OE</sup>

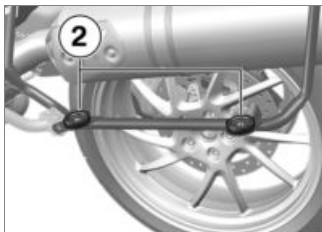

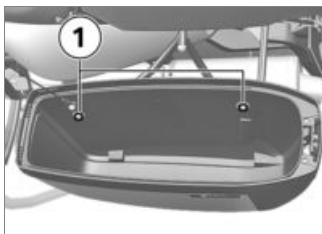

- Seat the case in mounts **2**.



- Install screws **1**.
- Close cases (➡ 136).

## Maximum payload and maximum permissible speed

Note the maximum permissible payload and the speed limit for riding with cases fitted, as stated on the label inside the case. Contact your authorised BMW Motorrad dealer if you cannot find your combination of vehicle and cases on the label. The values for the combination described here are as follows:

	Maximum permissible speed for riding with cases fitted to the motorcycle
	– with cases <sup>OA</sup>
	see label in case<
	Payload of cases
	– with cases <sup>OA</sup>
	see label in case<

## Topcase

### Opening topcase

– with topcase<sup>OA</sup>



- Turn key **1** in the topcase lock to the OPEN position.



- Push lock barrel **1** forward.  
» Lever **2** pops up.
- Pull the release lever all the way up.  
» The lid of the topcase opens.

### Closing topcase

– with topcase<sup>OA</sup>



- Pull release lever **1** all the way up.
- Close the lid of the topcase and hold it down. Check that nothing is trapped between the lid and the case.

### NOTICE

The topcase can also be locked by turning the lock to the LOCK position. In this case, ensure that the vehicle key is not left in the topcase.◀



- Push release lever **1** down until it engages.
- Turn the key in the topcase lock to the LOCK position and remove the key from the lock.

### Removing the topcase

– with topcase<sup>OA</sup>



- Turn key **1** in the topcase lock to the RELEASE position.  
» The handle pops out.



- Pull handle **1** up as far as it will go.

- Lift the topcase at the rear and remove it from the luggage carrier.

### Installing topcase

– with topcase<sup>OA</sup>

- Pull the handle up as far as it will go.

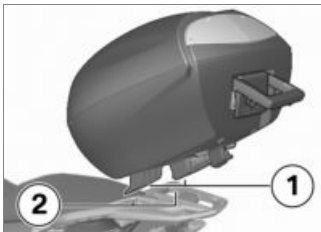

- Hook the topcase into position on the luggage carrier. Make sure that hooks **1** are securely seated in the corresponding keepers **2**.



- Push handle **1** down until it engages.
- Turn the key in the topcase lock to the LOCK position and remove the key from the lock.



### Maximum payload and maximum permissible speed

Note the maximum permissible payload and the speed limit for riding with topcase fitted, as stated on the label inside the topcase.

Contact your authorised BMW Motorrad dealer if you cannot

find your combination of vehicle and topcase on the label.

The values for the combination described here are as follows:

	Maximum permissible speed for riding with topcase fitted to the motorcycle
	– with topcase <sup>OA</sup>
	see label in topcase<
	Payload of topcase
	– with topcase <sup>OA</sup>
	see label in topcase<

## Two-way radio box

- with single seat with two-way radio box<sup>OE</sup>

## Opening two-way radio box

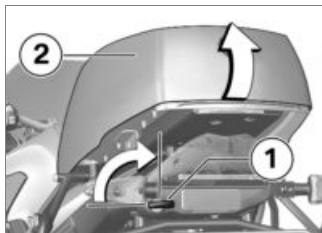

- Open lock **1** using the ignition key.
- Open lid **2** of the two-way radio box.

## Closing two-way radio box

- Close the lid of the two-way radio box and press it shut until the latch engages. Check that nothing is trapped between the lid and the case.

## Fire extinguisher

- with fire extinguisher complete with holder<sup>OE</sup>

## Removing fire extinguisher

The fire extinguisher is located in the left case.

- with cases, painted, with holder for special vehicle<sup>OE</sup>
- Open cases (►► 136).

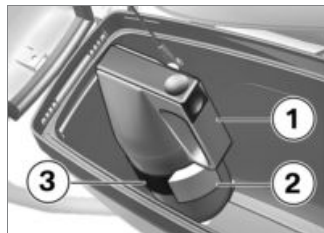

- Hold the fire extinguisher at the carry handle **1** and open closure **2** to release the retaining strap **3**.

- Remove fire extinguisher.

## Installing fire extinguisher

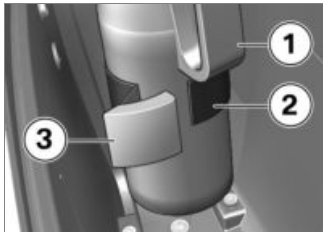

- Hold the fire extinguisher at the carry handle **1** and fit retaining strap **2**. Ensure that the fire extinguisher sits on the storage tray.
- Fit the right-hand side of the closure **3** to the retaining strap **2** and snap shut closure **3**.



## Care

Care products .....	144
Washing the vehicle .....	144
Cleaning easily damaged components.....	145
Paint care .....	146
Laying up the motorcycle .....	146
Protective wax coating .....	146
Restoring motorcycle to use .....	146

## Care products

BMW Motorrad recommends that you use the cleaning and care products you can obtain from your authorised BMW Motorrad dealer. The substances in BMW Care Products have been tested in laboratories and in practice; they provide optimised care and protection for the materials used in your vehicle.



### ATTENTION

#### Use of unsuitable cleaning and care products.

Damage to vehicle parts.

- Do not use solvents such as cellulose thinners, cold cleaners, fuel or the like, and do not use cleaning products that contain alcohol.◀

## Washing the vehicle

BMW Motorrad recommends that you use BMW insect remover to soften and wash off insects and stubborn dirt on painted parts prior to washing the motorcycle.

To prevent stains, do not wash the vehicle immediately after it has been exposed to strong sunlight and do not wash it in the sun.

The motorcycle should particularly be washed frequently during the winter months.

To remove road salt, clean the motorcycle with cold water immediately after every trip.



### ATTENTION

#### Effect of road salt intensified by warm water.

Corrosion

- Use only cold water to wash off road salt.◀



### WARNING

#### Wet brake discs and brake pads after vehicle wash, after riding through water and in rainy conditions.

Diminished braking effect.

- Apply the brakes in good time to allow the friction and heat to dry the brake discs and brake pads.◀



### ATTENTION

#### Damage due to high water pressure from high pressure cleaners or steam cleaners.

Corrosion or short-circuit, damage to seals, to the hydraulic brake system, to the electrics and the seat.

- Exercise restraint when using a steam jet or high-pressure cleaning equipment.◀

 **NOTICE**

Aluminium cases and topcases do not have a surface coating. Care in accordance with the instructions set out below will help ensure the best possible appearance:

Remove road salt and corrosive deposits by cleaning with cold water immediately after every trip.◀

## Cleaning easily damaged components

### Plastics

 **ATTENTION**

#### Use of unsuitable cleaning agents.

Damage to plastic surfaces.

- Do not use cleaning agents that contain alcohol, solvents or abrasives.

- Do not use insect-remover pads or cleaning pads with hard, scouring surfaces.◀

### Body panels

Clean the trim panels with water and BMW plastic care emulsion.

### Windscreen and headlight lens plastic

Clean off dirt and insects with a soft sponge and plenty of water.

 **NOTICE**

Soften stubborn dirt and insects by covering the affected areas with a wet cloth.◀

### Chrome parts

Use plenty of water and BMW shampoo to clean chrome, particularly if it has been exposed to road salt. Use chrome polish for additional treatment.

## Radiator

Clean the radiator regularly to prevent overheating of the engine due to inadequate cooling. For example, use a garden hose with low water pressure.

 **ATTENTION**

#### Radiator fins easily bent.

Damage to radiator fins.

- Take care not to bend the radiator fins when cleaning.◀

### Rubber components

Treat rubber components with water or BMW rubber-care products.

 **ATTENTION**

#### Application of silicone sprays to rubber seals.

Damage to the rubber seals.

- Do not use silicone sprays or care products that contain silicon.◀

## Paint care

Washing the vehicle regularly will help prevent damage to the paintwork, especially if your vehicle is ridden in areas with high air pollution or natural sources of dirt, for example tree resin or pollen.

However, particularly aggressive substances (e.g. spilled fuel, oil, grease, brake fluid and bird droppings) must be removed immediately, as the paint could otherwise be affected or become discoloured. We recommend BMW Motorrad BMW vehicle polish or BMW paint cleaner for this purpose.

Marks on the paintwork are particularly easy to see after the motorcycle has been washed. Remove stains of this kind immediately, using cleaning-grade benzene or petroleum spirit on a clean cloth or ball of cotton wool. BMW Motorrad recommend that

specks of tar be removed with BMW tar remover and the parts treated with this product should subsequently be waxed.

## Laying up the motorcycle

- Clean the motorcycle.
- Fill the motorcycle's fuel tank.
- Removing battery (▣▣▣▶ 128).
- Spray the brake and clutch lever pivots and the main and side stand pivots with a suitable lubricant.
- Coat bright metal and chrome-plated parts with an acid-free grease (e.g. Vaseline).
- Stand the motorcycle in a dry room in such a way that there is no load on either wheel (preferably using the front-wheel and rear-wheel stands from BMW Motorrad).

## Protective wax coating

If water is no longer forming beads on the paint surface, it must be waxed.

BMW Motorrad recommends applying only BMW car wax or products containing carnauba wax or synthetic wax.

## Restoring motorcycle to use

- Remove the protective wax coating.
- Clean the motorcycle.
- Installing battery (▣▣▣▶ 128).
- Comply with checklist (▣▣▣▶ 82).

## Technical data

Troubleshooting chart .....	148
Threaded fasteners .....	149
Engine .....	150
Fuel.....	151
Engine oil .....	151
Clutch .....	152
Transmission .....	152
Rear-wheel drive.....	153
Running gear .....	153
Brakes .....	154
Wheels and tyres .....	154
Electrics .....	156
Frame .....	158
Dimensions .....	159
Weights.....	160

Riding specifications .....	160
-----------------------------	-----

## Troubleshooting chart

Engine does not start at all or is difficult to start.

<b>Possible cause</b>	<b>Rectification</b>
Kill switch activated	Set kill switch to operating position (run).
Side stand extended and gear engaged	Select neutral or retract the side stand.
Gear engaged and clutch not disengaged	Select neutral or pull the clutch lever.
No fuel in tank	Refuelling (▣▶ 89).
Battery flat	Charge battery when connected (▣▶ 126).

## Threaded fasteners

Front wheel	FR	Valid
<b>Brake caliper on fork leg</b>		
M10 x 1.25 x 35 - 10.9	30 Nm	
<b>Clamp of quick-release axle</b>		
M8 x 30	<b>Tighten screws six times in alternate sequence</b>	
	19 Nm	
<b>Quick-release axle in telescopic forks</b>		
M24 x 1.5	50 Nm	
Rear wheel	FR	Valid
<b>Rear wheel to drive shaft</b>		
M10 x 1.25 x 40	<b>tighten in a crosswise sequence</b>	
	60 Nm	

## Engine

Engine design	Twin-cylinder 4-stroke engine, DOHC steering, 4 valves operated by rocker arm, liquid cooling for cylinder and cylinder head, integrated coolant pump, 6-speed gearbox and dry-sump lubrication
Displacement	798 cm <sup>3</sup>
Cylinder bore	82 mm
Piston stroke	75.6 mm
Compression ratio	12 : 1
Nominal output	66 kW, - at engine speed: 8000 min <sup>-1</sup>
- with power reduction to 25 kW <sup>OE</sup>	25 kW, - at engine speed: 7000 min <sup>-1</sup>
- with power reduction to 35 kW <sup>OE</sup>	35 kW, - at engine speed: 6750 min <sup>-1</sup>
Torque	86 Nm, - at engine speed: 5800 min <sup>-1</sup>
- with power reduction to 25 kW <sup>OE</sup>	55 Nm, - at engine speed: 3500 min <sup>-1</sup>
- with power reduction to 35 kW <sup>OE</sup>	69 Nm, - at engine speed: 3500 min <sup>-1</sup>
Maximum engine speed	max 9000 min <sup>-1</sup>
Idle speed	1250 <sup>+50</sup> min <sup>-1</sup> , vehicle at standstill

## Fuel

Recommended fuel grade	Super unleaded (max. 10 % ethanol, E10) 95 ROZ/RON 89 AKI
Usable fuel capacity	approx. 15 l
Reserve fuel	approx. 3 l

## Engine oil

Engine oil, capacity	approx. 3 l, with filter change
Viscosity class	
SAE 15W-50, API SJ / JASO MA2	Additives (e.g. molybdenum-based) are not permissible because they can attack coated components of the engine, BMW Motorrad recommends BMW Motorrad ADVANTEC Pro oil
Oil additives	BMW Motorrad recommends not using oil additives, because they can have a detrimental effect on clutch operation. Please do not hesitate to contact your authorised BMW Motorrad dealer if you have any questions relating the choice of a suitable engine oil for your motorcycle.

**BMW recommends** **ADVANTEC**  
ORIGINAL BMW ENGINE OIL

## Clutch

Clutch type	Multiplate clutch running in oil bath
-------------	---------------------------------------

## Transmission

Gearbox type	Claw-shift 6-speed transmission, integrated into engine block
Gearbox transmission ratios	1.943 (35/68 teeth), Primary transmission ratio 1:2.462 (13/32 teeth), 1st gear 1:1.750 (16/28 teeth), 2nd gear 1:1.381 (21/29 teeth), 3rd gear 1:1.174 (23/27 teeth), 4th gear 1:1.042 (24/25 teeth), 5th gear 1:0.960 (25/24 teeth), 6th gear

## Rear-wheel drive

Type of final drive	Belt drive with damper in special housing
---------------------	-------------------------------------------

## Running gear

### Front wheel

Type of front suspension	Telescopic forks
Spring travel, front	125 mm, at wheel

### Rear wheel

Type of rear suspension	Single-arm cast light-alloy swinging arm with cam-adjustable rear wheel axle
Type of rear suspension	Direct-acting central spring strut with adjustable rebound stage damping/spring preload
– with Electronic Suspension Adjustment (ESA) <sup>OE</sup>	Direct-acting central spring strut with adjustable spring preload/electrically adjustable rebound stage damping
Spring travel at rear wheel	125 mm, at wheel

## Brakes

### Front wheel

Type of front brake	Hydraulically operated twin disc brake with 4-piston fixed calipers and floating brake discs
Brake-pad material, front	Sintered metal

### Rear wheel

Type of rear brake	Hydraulically actuated 1-piston floating caliper with fixed brake disc
Brake-pad material, rear	Sintered metal

## Wheels and tyres

Recommended tyre sets	Your authorised BMW Motorrad dealer will be happy to supply an up-to-date list of the approved wheel/tyre combinations, or you can check the information posted on the <a href="http://bmw-motorrad.com">bmw-motorrad.com</a> website.
Speed category, front/rear tyres	V, required at least: 240 km/h
– with power reduction to 35 kW <sup>OE</sup> or – with power reduction to 25 kW <sup>OE</sup>	T, required at least: 190 km/h

**Front wheel**

Front wheel type	Cast aluminium, MT H2
Front wheel rim size	3.50" x 17"
Tyre designation, front	120/70 ZR 17
Load index, front tyre	min 49
– with power reduction to 35 kW <sup>OE</sup> or – with power reduction to 25 kW <sup>OE</sup>	min 45
Permissible front-wheel imbalance	max 5 g

**Rear wheel**

Rear-wheel type	Cast aluminium, MT H2
Rear wheel rim size	5.5" x 17"
Tyre designation, rear	180/55 ZR 17
Load index, rear tyre	min 70
– with power reduction to 35 kW <sup>OE</sup> or – with power reduction to 25 kW <sup>OE</sup>	min 66
Permissible rear-wheel imbalance	max 45 g

**Tyre pressure**

Tyre pressure, front	2.5 bar, tyre cold
Tyre pressure, rear	2.9 bar, tyre cold

**Electrics**

Electrical rating of on-board sockets	5 A, Power socket 10 A, Extra socket
---------------------------------------	-----------------------------------------

**Fuses**

Fuses	Electronic fuses protect all the circuits. If an electronic fuse trips and de-energises a circuit, the circuit is active as soon as the ignition is switched on after the fault has been rectified.
Retainer 1	10 A, Power socket
Retainer 2	10 A, Two-way radio
Retainer 3	10 A, Hailing system, plug for optional extras
Retainer 4	15 A, 360° strobe marker light, strobe marker light

Retainer 5	7.5 A, Two-way radio, hailing system, switches
Retainer 6	4 A, STOP signal
Retainer 7	4 A, STOP signal
Retainer 8	Not used

### **Battery**

Battery type	AGM (Absorbent Glass Mat) battery
Battery rated voltage	12 V
Battery rated capacity	12 Ah

### **Second battery**

Battery type	AGM (Absorbent Glass Mat) battery
Battery rated voltage	12 V
Rated capacity of the second battery	11.8 Ah
Engine rpm, starting from which the second battery is charged	min 2000 min <sup>-1</sup>

### **Spark plugs**

Spark plugs, manufacturer and designation	NGK DCPR 8 E
Electrode gap of spark plug	0.8...0.9 mm, when new

**Lighting**

Bulb for high-beam headlight	H7 / 12 V / 55 W
Bulbs for the low-beam headlight	H7 / 12 V / 55 W
Bulb for parking light	W5W / 12 V / 5 W
Bulb for tail light/brake light	P21/5W / 12 V / 5 W / 21 W
Bulbs for flashing turn indicators, front	RY10W / 12 V / 10 W
Bulbs for flashing turn indicators, rear	RY10W / 12 V / 10 W

**Frame**

Frame type	Cast light alloy weldment with bolt-on rear frame
Type plate location	Steering head, right
Position of the Vehicle Identification Number	Steering head, right

## Dimensions

Length of motorcycle	2156 mm
Height of motorcycle	1250 mm, without rider at unladen weight, to top edge of windscreen
Width of motorcycle	905 mm, across mirrors
Front-seat height	800 mm, without rider at unladen weight
– with Comfort seat <sup>OE</sup>	820 mm, without rider at unladen weight
– with seat, low <sup>OE</sup>	765 mm, without rider at unladen weight
Rider's inside-leg arc, heel to heel	1835 mm, without rider at unladen weight
– with Comfort seat <sup>OE</sup>	1860 mm, without rider at unladen weight
– with seat, low <sup>OE</sup>	1755 mm, without rider at unladen weight

## Weights

Unladen weight	213 kg, DIN unladen weight, ready for road, 90 % load of fuel, without optional extras
Permissible gross weight	420 kg
Maximum payload	207 kg

## Riding specifications

Top speed	>200 km/h
– with power reduction to 25 kW <sup>OE</sup>	approx. 155 km/h
– with power reduction to 35 kW <sup>OE</sup>	approx. 170 km/h

## **Service**

BMW Motorrad Service .....	162
BMW Motorrad Mobility services .....	162
Maintenance work .....	162
Maintenance schedule .....	165
Standard BMW service .....	166
Confirmation of maintenance work .....	167
Confirmation of service .....	172

## BMW Motorrad Service

BMW Motorrad has an extensive network of dealerships in place to look after you and your motorcycle in more than 100 countries. Authorised BMW Motorrad dealerships have the technical information and the technical know-how to reliably carry out all maintenance and repair work on your BMW.

You can locate your nearest authorised BMW Motorrad dealership by visiting our website:

**[bmw-motorrad.com](http://bmw-motorrad.com)**



### WARNING

#### **Maintenance and repair work not in compliance with correct procedure.**

Risk of accident due to subsequent damage.

- BMW Motorrad recommends you to have all the associated work on your motorcycle car-

ried out by a specialist workshop, preferably an authorised BMW Motorrad dealer. ◀

In order to help ensure that your BMW is always in optimum condition, BMW Motorrad recommends compliance with the maintenance intervals specified for your motorcycle. Have all maintenance and repair work that is carried out confirmed in the "Service" chapter in this manual. For generous treatment of claims submitted after the warranty period has expired, evidence of regular maintenance is essential.

Your authorised BMW Motorrad dealer can provide information on BMW services and the work undertaken as part of each service.

## BMW Motorrad Mobility services

As owner of a new BMW motorcycle, in circumstances in which assistance is required you can benefit from the protection afforded by the various BMW Motorrad mobility services (e.g. Mobile Service, breakdown service, vehicle recovery service). Your authorised BMW Motorrad dealer will be happy provide information about the mobility services available to you.

### Maintenance work

#### **BMW Pre-delivery Check**

Your authorised BMW Motorrad dealer conducts the BMW pre-delivery check before handing over the vehicle to you.

## BMW Running-in Check

The BMW running-in check has to be performed when the vehicle has covered between 500 km and 1200 km

## BMW Service

The BMW Service is carried out once a year; the extent of servicing can vary, depending on the age of the vehicle and the distance it has covered. Your authorised BMW Motorrad dealer confirms that the service work has been carried out and enters the date when the next service will be due.

Riders who cover long distances in a year might have to bring in their vehicles for service before the next scheduled date. It is to allow for these cases that a maximum odometer reading is entered as well in the confirmation of service. Servicing has to be brought forward if this odo-

meter reading is reached before the next scheduled date for the service.

The service-due indicator in the multifunction display reminds you about one month or 1000 km in advance when the time for a service is approaching, on the basis of the programmed values.

To find out more about service go to:

**[bmw-motorrad.com/service](http://bmw-motorrad.com/service)**

The maintenance tasks necessary for your vehicle are set out in the maintenance schedule below:



## Maintenance schedule

- 1** BMW Running-in check
- 2** Standard BMW service  
( 166)
- 3** Engine-oil change, with filter
- 4** Check valve clearance
- 5** Replace all spark plugs
- 6** Replace air-filter element
- 7** Replace belt and rear judder damper
- 8** Check the belt pulley, belt pinion and judder damper for belt pinion
- 9** Change brake fluid, entire system
  - a** annually or every 10,000 km (whichever comes first)
  - b** for the first time after one year, then every two years

## Standard BMW service

A standard BMW service consists of the following maintenance work:

- Perform vehicle test with the BMW Motorrad diagnosis system.
- Check the coolant level.
- Check/adjust the clutch play.
- Check the freedom of movement of the throttle cable and check for kinks and chafing.
- Check the front and rear brake pads and brake discs for wear.
- Check the front and rear brake-fluid levels.
- Visually inspect the brake pipes, brake hoses and connections.
- Check the tyre pressures and tread depth.
- Check the toothed belt.
- Check the belt tension.
- Check the steering-head bearing.
- Check the ease of movement of the side stand.
- Check the ease of movement of the centre stand (if vehicle fitted with the "centre stand" optional extra).
- Check the specified torque of threaded fasteners with torque wrench: main frame.
- Check the specified torque of threaded fasteners with torque wrench: left and right front footrest plates.
- Check the specified torque with torque wrench: eccentric clamp.
- Check the lights and signalling equipment.
- Check that the engine start suppression system is in working order.
- Perform final inspection and check of roadworthiness.
- Set the service-due date and service countdown distance.
- Check the battery charge state.
- Confirm BMW service in the on-board documentation.

## Confirmation of maintenance work

### **BMW Pre-delivery Check**

Completed

on \_\_\_\_\_

\_\_\_\_\_  
Stamp, signature

### **BMW Running-in Check**

Completed

on \_\_\_\_\_

Odometer reading \_\_\_\_\_

Next service  
at the latest

on \_\_\_\_\_

or, if logged beforehand,

Odometer reading \_\_\_\_\_

\_\_\_\_\_  
Stamp, signature

**BMW Service**

Completed

on \_\_\_\_\_

Odometer reading \_\_\_\_\_

Next service  
at the latest

on \_\_\_\_\_

or, if logged beforehand,

Odometer reading \_\_\_\_\_

\_\_\_\_\_  
Stamp, signature**BMW Service**

Completed

on \_\_\_\_\_

Odometer reading \_\_\_\_\_

Next service  
at the latest

on \_\_\_\_\_

or, if logged beforehand,

Odometer reading \_\_\_\_\_

\_\_\_\_\_  
Stamp, signature**BMW Service**

Completed

on \_\_\_\_\_

Odometer reading \_\_\_\_\_

Next service  
at the latest

on \_\_\_\_\_

or, if logged beforehand,

Odometer reading \_\_\_\_\_

\_\_\_\_\_  
Stamp, signature

**BMW Service**

Completed

on \_\_\_\_\_

Odometer reading \_\_\_\_\_

Next service  
at the latest

on \_\_\_\_\_

or, if logged beforehand,

Odometer reading \_\_\_\_\_

\_\_\_\_\_  
Stamp, signature**BMW Service**

Completed

on \_\_\_\_\_

Odometer reading \_\_\_\_\_

Next service  
at the latest

on \_\_\_\_\_

or, if logged beforehand,

Odometer reading \_\_\_\_\_

\_\_\_\_\_  
Stamp, signature**BMW Service**

Completed

on \_\_\_\_\_

Odometer reading \_\_\_\_\_

Next service  
at the latest

on \_\_\_\_\_

or, if logged beforehand,

Odometer reading \_\_\_\_\_

\_\_\_\_\_  
Stamp, signature

**BMW Service**

Completed

on \_\_\_\_\_

Odometer reading \_\_\_\_\_

Next service  
at the latest

on \_\_\_\_\_

or, if logged beforehand,

Odometer reading \_\_\_\_\_

\_\_\_\_\_  
Stamp, signature**BMW Service**

Completed

on \_\_\_\_\_

Odometer reading \_\_\_\_\_

Next service  
at the latest

on \_\_\_\_\_

or, if logged beforehand,

Odometer reading \_\_\_\_\_

\_\_\_\_\_  
Stamp, signature**BMW Service**

Completed

on \_\_\_\_\_

Odometer reading \_\_\_\_\_

Next service  
at the latest

on \_\_\_\_\_

or, if logged beforehand,

Odometer reading \_\_\_\_\_

\_\_\_\_\_  
Stamp, signature

**BMW Service**

Completed

on \_\_\_\_\_

Odometer reading \_\_\_\_\_

Next service  
at the latest

on \_\_\_\_\_

or, if logged beforehand,

Odometer reading \_\_\_\_\_

\_\_\_\_\_  
Stamp, signature**BMW Service**

Completed

on \_\_\_\_\_

Odometer reading \_\_\_\_\_

Next service  
at the latest

on \_\_\_\_\_

or, if logged beforehand,

Odometer reading \_\_\_\_\_

\_\_\_\_\_  
Stamp, signature**BMW Service**

Completed

on \_\_\_\_\_

Odometer reading \_\_\_\_\_

Next service  
at the latest

on \_\_\_\_\_

or, if logged beforehand,

Odometer reading \_\_\_\_\_

\_\_\_\_\_  
Stamp, signature

## Confirmation of service

The table is intended as a record of maintenance and repair work, the installation of optional accessories and, if appropriate, special campaign (recall) work.

Item	Odometer reading	Date





## Appendix

Certificate for electronic immobiliser .....	176
Certificate for tyre pressure monitoring (Reifendruck-Control, RDC) .....	178

## FCC Approval

### Ring aerial in the ignition switch



To verify the authorization of the ignition key, the electronic immobilizer exchanges information with the ignition key via the ring aerial.

This device complies with Part 15 of the FCC rules. Operation is subject to the following two conditions:

- (1) This device may not cause harmful interference, and
- (2) this device must accept any interference received, including interference that may cause undesired operation.



Any changes or modifications not expressly approved by the party responsible for compliance could void the user's authority to operate the equipment. ◀

## Approbation de la FCC

### Antenne annulaire présente dans le commutateur d'allumage



Pour vérifier l'autorisation de la clé de contact, le système d'immobilisation électronique échange des

informations avec la clé de contact via l'antenne annulaire.

Le présent dispositif est conforme à la partie 15 des règles de la FCC. Son utilisation est soumise aux deux conditions suivantes :

- (1) Le dispositif ne doit pas produire d'interférences nuisibles, et
- (2) le dispositif doit pouvoir accepter toutes les interférences extérieures, y compris celles qui pourraient provoquer une activation inopportune.



Toute modification qui n'aurait pas été approuvée expressément par l'organisme responsable de l'homologation peut annuler l'autorisation accordée à l'utilisateur pour utiliser le dispositif. ◀

## Certification Tire Pressure Control (TPC)

---

FCC ID: MRXBC54MA4  
IC: 2546A-BC54MA4

FCC ID: MRXBC5A4  
IC: 2546A-BC5A4

This device complies with Part 15 of the FCC Rules and with Industry Canada license-exempt RSS standard(s).

Operation is subject to the following two conditions:

- (1) This device may not cause harmful interference, and
- (2) This device must accept any interference received, including interference that may cause undesired operation.

Le présent appareil est conforme aux CNR d'Industrie Canada applicables aux appareils radio exempts de licence. L'exploitation est autorisée aux deux conditions suivantes:

- (1) l'appareil ne doit pas produire de brouillage, et
- (2) l'utilisateur de l'appareil doit accepter tout brouillage radioélectrique subi, même si le brouillage est susceptible d'en compromettre le fonctionnement.

**WARNING:** Changes or modifications not expressly approved by the party responsible for compliance could void the user's authority to operate the equipment. The term "IC:" before the radio certification number only signifies that Industry Canada technical specifications were met.

## 3

- 360° marker strobe
  - Control, 25
  - Operation, 54
  - Position on the motorcycle, 17

## A

- Abbreviations and symbols, 6
- ABS
  - Engineering details, 94
  - Self-diagnosis, 84
  - Warnings, 39
- Accessories
  - General instructions, 132
- Actuality, 7
- Ambient temperature
  - Outside temperature warning, 34
  - Reading, 42
- ASC
  - Control, 21
  - Engineering details, 96
  - Operation, 58
  - Self-diagnosis, 84
  - Warnings, 39

- Average values
  - Resetting, 49

## B

- Battery
  - Charging battery when connected, 126
  - Charging battery when disconnected, 127
  - Installation, 128
  - Maintenance instructions, 125
  - Position on the motorcycle, 20
  - Removal, 128
  - Second battery, position on the motorcycle, 17
  - Technical data, 157
- Brake fluid
  - Checking fluid level, front, 104
  - Checking fluid level, rear, 105
  - Reservoir, front, 15
  - Reservoir, rear, 15
- Brake pads
  - Checking front, 103
  - Checking rear, 103
  - Running in, 86

## Brakes

- Adjusting handlebar lever, 60
- Checking operation, 102
- Safety instructions, 87
- Technical data, 154

## C

- Cases
  - Operation, 133
- Cases for special vehicles
  - Operation, 136
  - Position on the vehicle, 13
- Checklist, 82
- Clock
  - adjusting, 47
  - Control, 26
- Clutch
  - Adjusting handlebar lever, 59
  - Adjusting play, 108
  - Checking operation, 107
  - Checking play, 107
  - Technical data, 152
- Confirmation of maintenance work, 167

**Coolant**

- Checking fill level, 106
- Fill-level indicator, 15
- Warning for overtemperature, 34

**D****Damping**

- Adjuster, 15
- adjusting, 62

**Dimensions**

- Technical data, 159

**DWA**

- Telltale light, 26
- Warnings, 36

**E****Electrics**

- Technical data, 156

**Emergency off switch (kill switch), 24**

- Operation, 57

**Engine**

- starting, 82
- Technical data, 150
- Warning for engine electronics, 35

**Engine guard**

- Position on the motorcycle, 17

**Engine oil**

- Checking fill level, 101
- Filler neck, 11
- Oil dipstick, 11
- Technical data, 151
- Topping up, 102

**Equipment, 7****ESA**

- Control, 21
- Operation, 63

**Extra socket**

- Position on the motorcycle, 17

**F****Fire extinguisher, 140**

- Position on the vehicle, 13

**First-aid kit**

- Position on the vehicle, 13
- Stowage, 18

**Frame**

- Technical data, 158

**Front-wheel stand**

- Installing, 114

**Fuel**

- Filler neck, 15
- Fill-level indicator, 40
- Fuel reserve, 41
- Refuelling, 89
- Technical data, 151

**Fuel reserve**

- Warning, 38

**Fuses, 156**

- Position on the motorcycle, 19
- Replacing, 122
- Technical data, 156

**G****General views**

- Instrument panel, 26
- Left handlebar fitting, 22
- Left side of motorcycle, 11
- Left side of vehicle, 13
- Multifunction display, 29
- Multifunction switch, left, 21
- Right handlebar fitting, 24, 25

Right side of motorcycle, 15, 17  
Underneath the seat, 18, 19  
Underneath the trim panel, 20  
Warning and telltale lights, 28

## H

Hailing system  
Control, 22  
Loudspeaker, position on the motorcycle, 13  
Hazard warning flashers  
Control, 21  
Operation, 53  
Headlight  
Adjusting headlight beam throw, 65  
Adjustment for driving on left/driving on right, 64  
Beam throw, 65  
Heated handlebar grips  
Control, 24  
Operation, 57

Helmet holder  
Helmet, securing, 67  
Position on the vehicle, 18  
Horn, 21

## I

Ignition  
Switching off, 46  
Switching on, 46  
Immobiliser  
Reserve key, 47  
Warning, 34  
Instrument panel  
Ambient-light brightness sensor, 26  
Overview, 26

## J

Jump starting, 124

## K

Keys, 46

## L

Lap-Timer, 51  
Light signals  
Operating "STOP" signal, 54

## Lighting

Replacing bulb for parking light, 118  
Replacing high-beam headlight bulb, 117  
Replacing low-beam headlight bulb, 117  
Replacing the brake light and rear light bulbs, 120  
Technical data, 158  
Warning for bulb failure, 35

## Lights

Adjusting headlight beam throw, 11  
Control, 21  
Headlight flasher, operating, 52  
High-beam headlight, operating, 52  
Low-beam headlight, 52  
Parking lights, operating, 52  
Side light, 51  
Lights-off setting  
Control, 25  
Operation, 55

**Loudspeaker**

For hailing system, position on the motorcycle, 13

For siren, position on the motorcycle, 13

**Luggage**

Instructions for loading, 80

**M****Maintenance**

General instructions, 100

Maintenance schedule, 165

**Maintenance intervals, 162****Marker strobe**

Control, 25

Operation, 53

Position on the motorcycle, 17

**Mirrors**

adjusting, 61

**Mobility services, 162****Motorcycle**

Care, 143

Cleaning, 143

Lashing, 91

Laying up, 146

Parking, 88

**Multifunction display**

Control, 21

Meaning of symbols, 40

Overview, 29

**Multifunction switch**

General view, left side, 21, 22

General view, right side, 24, 25

**O****Odometer**

Control, 26

Resetting, 49

**P****Parking, 88****Power socket**

Notes on use, 132

Position on the motorcycle, 15

**Pre-Ride-Check, 83****R****RDC**

Adhesive label for rim, 109

Engineering details, 97

Reading, 43

Warnings, 36

**Rear-wheel drive**

Technical data, 153

**Rear-wheel stand**

Installing, 116

**Redline warning**

Switching on, 86, 87

Warning light, 26

**Refuelling, 89****Rev. counter, 26****Rider's Manual**

Position on the vehicle, 13, 18

**Running gear**

Technical data, 153

**Running in, 86****S****Safety instructions**

For brake, 87

For riding, 80

- Seat
  - Installation, 65
  - Lock, 11
  - Removal, 65
- Second battery
  - Position on the motorcycle, 17
  - Technical data, 157
- Service, 162
- Service toolkit
  - Position on the vehicle, 13
  - Stowage, 18
- Service-due indicator, 41
- Siren
  - Control, 22
  - Loudspeaker, position on the motorcycle, 13
  - Operation, 55, 56
- Spark plugs
  - Technical data, 157
- Speedometer, 26
- Spring preload
  - Adjuster, 15
  - adjusting, 61
  - Tools, 18
- Starting, 82
  - Control, 24
- Steering lock
  - Locking, 46
- STOP signal
  - Position on the motorcycle, 17
- Stopwatch
  - Operation, 50
- Symbols in display
  - Meaning, 40
- T**
- Technical data
  - Battery, 157
  - Brakes, 154
  - Bulbs, 158
  - Clutch, 152
  - Dimensions, 159
  - Electrics, 156
  - Engine, 150
  - Engine oil, 151
  - Frame, 158
  - Fuel, 151
  - Rear-wheel drive, 153
  - Running gear, 153
  - Second battery, 157
  - Spark plugs, 157
  - Standards, 7
  - Transmission, 152
  - Weights, 160
  - Wheels and tyres, 154
- Telltale lights
  - Overview, 28
- Toolkit
  - Contents, 100
  - Position on the vehicle, 13, 18
- Topcase
  - Operation, 137
- Torques, 149
- Transmission
  - Technical data, 152
- Trim panels
  - Installing centre trim panel, 123
  - Removing centre trim panel, 123
- Troubleshooting chart, 148
- Turn indicators
  - Control, 21
  - Operation, 52

- Twistgrip brake
  - Control, 25
  - Operation, 85
- Two-way radio box
  - Operation, 140
  - Position on the vehicle, 13
- Type plate
  - Position on the motorcycle, 15
- Tyre repair kit
  - Stowage, 20
- Tyres
  - Checking inflation pressure, 64
  - Checking tread depth, 108
  - Pressures, 156
  - Recommendation, 109
  - Running in, 86
  - Table of tyre pressures, 18
  - Technical data, 154
- V**
- Vehicle
  - Restoring to use, 146
- Vehicle Identification Number
  - Position on the motorcycle, 15

- W**
- Warning lights
  - Overview, 28
- Warnings
  - ABS, 39
  - Anti-theft alarm, 36
  - ASC, 39
  - Bulb defect, 35
  - Coolant temperature, 34
  - Engine electronics, 35
  - Fuel reserve, 38
  - Immobiliser, 34
  - Mode of presentation, 30
  - Outside temperature warning, 34
  - RDC, 36
- Warnings, overview, 31
- Weights
  - Payload table, 11
  - Technical data, 160
- Wheels
  - Change of size, 109
  - Checking rims, 108
  - Installing front wheel, 111
  - Installing the rear wheel, 114

- Removing front wheel, 110
- Removing rear wheel, 113
- Technical data, 154



Details described or illustrated in this booklet may differ from the vehicle's actual specification as purchased, the accessories fitted or the national-market specification. No claims will be entertained as a result of such discrepancies.

Dimensions, weights, fuel consumption and performance data are quoted to the customary tolerances.

The right to modify designs, equipment and accessories is reserved.

Errors and omissions excepted.

© 2015 Bayerische Motoren Werke Aktiengesellschaft  
80788 Munich, Germany  
Not to be reproduced by any means whatsoever, wholly or in part, without the written permission of BMW Motorrad, After Sales.

Original rider's manual, printed in Germany.

